



Designation: E 647 – 95

## Standard Test Method for Measurement of Fatigue Crack Growth Rates<sup>1</sup>

This standard is issued under the fixed designation E 647; the number immediately following the designation indicates the year of original adoption or, in the case of revision, the year of last revision. A number in parentheses indicates the year of last reapproval. A superscript epsilon ( $\epsilon$ ) indicates an editorial change since the last revision or reapproval.

### 1. Scope

1.1 This test method<sup>2</sup> covers the determination of steady-state fatigue crack growth rates from near-threshold to  $K_{max}$  controlled instability using either compact tension, C(T), (Fig. 1) or middle-tension, M(T), (Fig. 2) specimens. Results are expressed in terms of the crack-tip stress-intensity factor range ( $\Delta K$ ), defined by the theory of linear elasticity.

1.2 Several different test procedures are provided, the optimum test procedure being primarily dependent on the magnitude of the fatigue crack growth rate to be measured.

1.3 Materials that can be tested by this test method are not limited by thicknesses or by strength so long as specimens are of sufficient thickness to preclude buckling and of sufficient planar size to remain predominantly elastic during testing.

1.4 A range of specimen sizes with proportional planar dimensions is provided, but size is variable to be adjusted for yield strength and applied load. Specimen thickness may be varied independent of planar size.

1.5 Specimen configurations other than those contained in this method may be used provided that well-established stress-intensity factor calibrations are available and that specimens are of sufficient planar size to remain predominantly elastic during testing.

1.6 Residual stress/crack closure may significantly influence the fatigue crack growth rate data, particularly at low stress-intensity factors and low stress ratios, although such variables are not incorporated into the computation of  $\Delta K$ .

1.7 Values stated in SI units are to be regarded as the standard. Values given in parentheses are for information only.

1.8 *This standard does not purport to address all of the safety concerns, if any, associated with its use. It is the responsibility of the user of this standard to establish appropriate safety and health practices and determine the applicability of regulatory limitations prior to use.*

### 2. Referenced Documents

#### 2.1 ASTM Standards:

- E 4 Practices for Force Verification of Testing Machines<sup>3</sup>
- E 6 Terminology Relating to Methods of Mechanical Testing<sup>3</sup>
- E 8 Test Methods for Tension Testing of Metallic Materials<sup>3</sup>

<sup>1</sup> This test method is under the jurisdiction of ASTM Committee E-8 on Fatigue and Fracture and is the direct responsibility of Subcommittee E08.06 on Crack Growth Behavior.

Current edition approved Apr. 15, 1995. Published June 1995. Originally published as E 647 – 78 T. Last previous edition E 647 – 93.

<sup>2</sup> For additional information on this test method see RR: E 24 – 1001. Available from ASTM Headquarters, 1916 Race Street, Philadelphia, PA 19103.

<sup>3</sup> Annual Book of ASTM Standards, Vol 03.01.

E 337 Test Method for Measuring Humidity with a Psychrometer (the Measurement of Wet- and Dry-Bulb Temperatures)<sup>4</sup>

E 338 Test Method for Sharp-Notch Tension Testing of High-Strength Sheet Materials<sup>3</sup>

E 399 Test Method for Plane-Strain Fracture Toughness of Metallic Materials<sup>3</sup>

E 467 Practice for Verification of Constant Amplitude Dynamic Loads on Displacements in an Axial Load Fatigue Testing System<sup>3</sup>

E 561 Practice for R-Curve Determination<sup>3</sup>

E 616 Terminology Relating to Fracture Testing<sup>3</sup>

E 813 Test Method for  $J_{Ic}$ , A Measure of Fracture Toughness<sup>3</sup>

E 1150 Definitions of Terms Relating to Fatigue<sup>3</sup>

### 3. Terminology

3.1 The terms used in this test method are given in Terminology E 6, Definitions E 1150, and Terminology E 616. Wherever these terms are not in agreement with one another, use the definitions given in Terminology E 616 which are applicable to this test method.

#### 3.2 Definitions:

3.2.1 *crack length,  $a[L]$ ,  $n$* —See *crack size*.

3.2.2 *crack size,  $a[L]$ ,  $n$* —a linear measure of a principal planar dimension of a crack. This measure is commonly used in the calculation of quantities descriptive of the stress and displacement fields and is often also termed crack length or depth.

*Discussion*—In the C(T) specimen,  $a$  is measured from the line connecting the bearing points of load application; in the M(T) specimen,  $a$  is measured from the perpendicular bisector of the central crack.

*Discussion*—In fatigue testing, crack length is the physical crack size. See *physical crack size* in Terminology E 616.

3.2.3 *cycle—in fatigue*, under constant amplitude loading, the load variation from the minimum to the maximum and then to the minimum load.

*Discussion*—In spectrum loading, the definition of cycle varies with the counting method used.

*Discussion*—In this test method, the symbol  $N$  is used to represent the number of cycles.

3.2.4 *fatigue-crack-growth rate,  $da/dN$ ,  $[L]$* —crack extension per cycle of loading.

3.2.5 *fatigue cycle*—See *cycle*.

3.2.6 *load cycle*—See *cycle*.

3.2.7 *load range,  $\Delta P$   $[F]$* —in fatigue, the algebraic

<sup>4</sup> Annual Book of ASTM Standards, Vol 11.03.

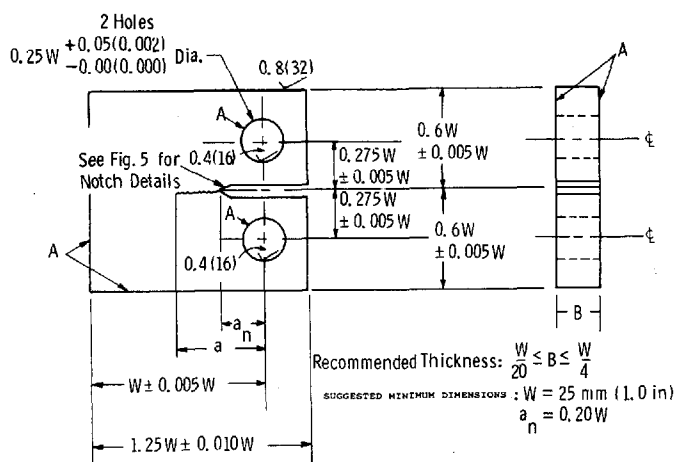

NOTE 1—Dimensions are in millimetres (inches).  
 NOTE 2—A-surfaces shall be perpendicular and parallel as applicable to within 0.002 W, TIR.  
 NOTE 3—The intersection of the tips of the machined notch ( $a_n$ ) with the specimen faces shall be equally distant from the top and bottom edges of the specimen to within 0.005 W.

FIG. 1 Standard Compact-Tension C(T) Specimen for Fatigue Crack Growth Rate Testing

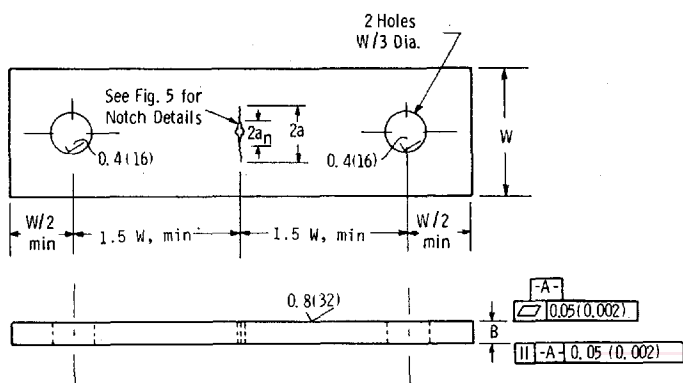

NOTE 1—Dimensions are in millimetres (inches).  
 NOTE 2—The machined notch ( $2a_n$ ) shall be centered to within  $\pm 0.001 W$ .  
 NOTE 3—For specimens with  $W > 75$  mm (3 in.) a multiple pin gripping arrangement is recommended, similar to that described in Practice E 561.

FIG. 2 Standard Middle-Tension M(T) Specimen for Fatigue Crack Growth Rate Testing when  $W \leq 75$  mm (3 in.)

difference between the maximum and minimum loads in a cycle expressed as:

$$\Delta P = P_{\max} - P_{\min}$$

3.2.8 *load ratio* (also called *stress ratio*),  $R$ —*in fatigue*, the algebraic ratio of the minimum to maximum load (stress) in a cycle, that is,  $R = P_{\min}/P_{\max}$ .

3.2.9 *maximum load*,  $P_{\max}$  [F]—*in fatigue*, the highest algebraic value of applied load in a cycle tensile loads are considered positive and compressive loads negative.

3.2.10 *maximum stress-intensity factor*,  $K_{\max}$  [ $FL^{-3/2}$ ]—*in fatigue*, the maximum value of the stress-intensity factor in a cycle. This value corresponds  $P_{\max}$ .

3.2.11 *minimum load*,  $P_{\min}$  [F]—*in fatigue*, the lowest algebraic value of applied load in a cycle. Tensile loads are considered positive and compressive loads negative.

3.2.12 *minimum stress-intensity factor*,  $K_{\min}$  [ $FL^{-3/2}$ ]—*in fatigue*, the minimum value of the stress-intensity factor in a

cycle. This value corresponds to  $P_{\min}$  when  $R > 0$  and is taken to be zero when  $R \leq 0$ .

3.2.13 *stress cycle*—See cycle in Terminology E 616.

3.2.14 *stress-intensity factor*,  $K$ ,  $K_1$ ,  $K_2$ ,  $K_3$  [ $FL^{-3/2}$ ]—See Terminology E 616.

*Discussion*—In this test method, mode 1 is assumed and the subscript 1 is everywhere implied.

3.2.15 *stress-intensity factor range*,  $\Delta K$  [ $FL^{-3/2}$ ]—*in fatigue*, the variation in the stress-intensity factor in a cycle, that is

$$\Delta K = K_{\max} - K_{\min}$$

*Discussion*—The loading variables  $R$ ,  $\Delta K$ , and  $K_{\max}$  are related in accordance with the following relationships:

$$\Delta K = (1 - R)K_{\max} \text{ for } R \geq 0, \text{ and}$$

$$\Delta K = K_{\max} \text{ for } R \leq 0.$$

*Discussion*—These operational stress-intensity factor definitions do not include local crack-tip effects; for example, crack closure, residual stress, and blunting.

*Discussion*—While the operational definition of  $\Delta K$  states that  $\Delta K$  does not change for a constant value of  $K_{\max}$  when  $R \leq 0$ , increases in fatigue crack growth rates can be observed when  $R$  becomes more negative. Excluding the compressive loads in the calculation of  $\Delta K$  does not influence the material's response since this response ( $da/dN$ ) is independent of the operational definition of  $\Delta K$ . For predicting crack-growth lives generated under various  $R$  conditions, the life prediction methodology must be consistent with the data reporting methodology.

3.2.16 *stress-intensity factor range*—See range of stress-intensity factor.

### 3.3 Description of Terms Specific to This Standard:

3.3.1 *applied-K curve*—a curve (a fixed-load or fixed-displacement crack-extension-force curve) obtained from a fracture mechanics analysis for a specific specimen configuration. The curve relates the stress-intensity factor to crack size and either applied load or displacement.

*Discussion*—The resulting analytical expression is sometimes called a  $K$  calibration and is frequently available in handbooks for stress-intensity factors.

3.3.2 *fatigue crack growth threshold*,  $\Delta K_{th}$  [ $FL^{-3/2}$ ]—that asymptotic value of  $\Delta K$  at which  $da/dN$  approaches zero. For most materials an *operational*, though arbitrary, definition of  $\Delta K_{th}$  is given as that  $\Delta K$  which corresponds to a fatigue crack growth rate of  $10^{-10}$  m/cycle. The procedure for determining this *operational*  $\Delta K_{th}$  is given in 9.4.

*Discussion*—The intent of this definition is not to define a true threshold, but rather to provide a practical means of characterizing a material's fatigue crack growth resistance in the near-threshold regime. Caution is required in extending this concept to design (see 5.1.5).

3.3.3 *fatigue crack growth rate*,  $da/dN$  or  $\Delta a/\Delta N$ , [L]—*in fatigue*, the rate of crack extension caused by fatigue loading and expressed in terms of average crack extension per cycle.

3.3.4 *K-decreasing test*—a test in which the value of  $C$  is nominally negative. In this test method  $K$ -decreasing tests are conducted by shedding load, either continuously or by a series of decremental steps, as the crack grows.

3.3.5 *K-increasing test*—a test in which the value of  $C$  is nominally positive. For the standard specimens in this

method the constant-load-amplitude test will result in a  $K$ -increasing test where the  $C$  value increases but is always positive.

3.3.6 *normalized  $K$ -gradient*,  $C = (1/K) \cdot dK/da[L^{-1}]$ —the fractional rate of change of  $K$  with increasing crack length.

*Discussion*—When  $C$  is held constant the percentage change in  $K$  is constant for equal increments of crack length. The following identity is true for the normalized  $K$ -gradient in a constant load ratio test:

$$\frac{1}{K} \cdot \frac{dK}{da} = \frac{1}{K_{\max}} \cdot \frac{dK_{\max}}{da} = \frac{1}{K_{\min}} \cdot \frac{dK_{\min}}{da} = \frac{1}{\Delta K} \cdot \frac{d\Delta K}{da}$$

#### 4. Summary of Test Method

4.1 This test method involves cyclic loading of notched specimens which have been acceptably precracked in fatigue. Crack length is measured, either visually or by an equivalent method<sup>5</sup>, as a function of elapsed fatigue cycles and these data are subjected to numerical analysis to establish the rate of crack growth. Crack growth rates are expressed as a function of the stress-intensity factor range,  $\Delta K$ , which is calculated from expressions based on linear elastic stress analysis.

#### 5. Significance and Use

5.1 Fatigue crack growth rate expressed as a function of crack-tip stress-intensity factor range,  $da/dN$  versus  $\Delta K$ , characterizes a material's resistance to stable crack extension under cyclic loading. Background information on the rationale for employing linear elastic fracture mechanics to analyze fatigue crack growth rate data is given in Refs (1) and (3).<sup>6</sup>

5.1.1 In innocuous (inert) environments fatigue crack growth rates are primarily a function of  $\Delta K$  and load ratio,  $R$ , or  $K_{\max}$  and  $R$  (Note 1). Temperature and aggressive environments can significantly affect  $da/dN$  versus  $\Delta K$ , and in many cases accentuate  $R$ -effects and introduce effects of other loading variables such as cycle frequency and waveform. Attention needs to be given to the proper selection and control of these variables in research studies and in the generation of design data.

NOTE 1— $\Delta K$ ,  $K_{\max}$ , and  $R$  are not independent of each other. Specification of any two of these variables is sufficient to define the loading condition. It is customary to specify one of the stress-intensity parameters ( $\Delta K$  or  $K_{\max}$ ) along with the load ratio,  $R$ .

5.1.2 Expressing  $da/dN$  as a function of  $\Delta K$  provides results that are independent of planar geometry, thus enabling exchange and comparison of data obtained from a variety of specimen configurations and loading conditions. Moreover, this feature enables  $da/dN$  versus  $\Delta K$  data to be utilized in the design and evaluation of engineering structures. The concept of similitude is assumed, which implies that cracks of differing lengths subjected to the same nominal  $\Delta K$  will advance by equal increments of crack extension per cycle.

5.1.3 Fatigue crack growth rate data are not always

<sup>5</sup> Subcommittee E08.06 has initiated a task group activity (E08.06.06) on nonvisual methods for measuring crack growth. These measurement methods include compliance (near front face and back face), a-c potential, d-c potential, eddy current, ultrasonic, and acoustic emission. Refs (1) and (2) provide basic information on the current uses of these methods.

<sup>6</sup> The boldface numbers in parentheses refer to the list of references at the end of this standard.

geometry-independent in the strict sense since thickness effects sometimes occur. However, data on the influence of thickness on fatigue crack growth rate are mixed. Fatigue crack growth rates over a wide range of  $\Delta K$  have been reported to either increase, decrease, or remain unaffected as specimen thickness is increased. Thickness effects can also interact with other variables such as environment and heat treatment. In addition, materials may exhibit thickness effects only over the terminal range of  $da/dN$  versus  $\Delta K$ , which are associated with either nominal yielding (Note 2) or as  $K_{\max}$  approaches the material fracture toughness. The potential influence of specimen thickness should be considered when generating data for research or design.

NOTE 2—This condition should be avoided in tests that conform to the specimen size requirements of 7.2.

5.1.4 Residual stresses can have an influence on fatigue crack growth rate behavior. The effect can be significant when test specimens are removed from material in which complete stress relief is impractical, such as weldments, as-quenched materials, and complex forged or extruded shapes. Residual stresses superimposed on the applied stress can cause the localized crack-tip stress-intensity factor to be different than that computed solely from externally applied loads. Residual stresses may lead to partly compressive stress cycles, even when the nominal applied stress range is wholly tensile, or vice versa. Irregular crack growth, namely excessive crack front curvature or out-of-plane crack growth, generally indicates that residual stresses are affecting the measured  $da/dN$  versus  $\Delta K$  relationship (4).

5.1.5 Small fatigue cracks have been observed to exhibit equal to or greater propagation rates than corresponding long fatigue cracks subjected to the same nominal  $\Delta K$ . This effect may be accentuated by environmental factors. Cracks are defined as being small when 1) their length is small compared to relevant microstructural dimension (a continuum mechanics limitation), 2) their length is small compared to the scale of local plasticity (a linear elastic fracture mechanics limitation), and 3) they are merely physically small (<1 mm). Near-threshold data established according to this method should be considered as representing the materials' steady-state fatigue crack growth rate response emanating from a long crack, one that is of sufficient length such that transition from the initiation to propagation stage of fatigue is complete. If near-threshold data generated under long crack test conditions are used to predict service lifetimes in components containing small cracks, non-conservative lifetime estimates may result (5, 6, 7).<sup>7</sup>

5.1.6 Crack closure can have a dominant influence on fatigue crack growth rate behavior in the near-threshold regime at low stress ratios. This implies that the conditions in the wake of the crack and prior loading history can have a bearing on the current propagation rates. The understanding of the role of the closure process is essential to such phenomena as the behavior of small cracks and the transient crack growth rate behavior during variable amplitude loading. Closure provides a mechanism whereby the cyclic

<sup>7</sup> Subcommittee E08.06 has initiated a study group activity on crack closure measurement and analysis. Reference (8) provides basic information on this subject.

stress intensity near the crack tip,  $\Delta K_{eff}$ , differs from the nominally applied values,  $\Delta K$ . This concept is of importance to the fracture mechanics interpretation of fatigue crack growth rate data since it implies a non-unique growth rate dependence in terms of  $\Delta K$ , and  $R$  (8).<sup>9</sup>

NOTE 3—The characterization of small crack behavior may be more closely approximated in the near-threshold regime by testing at a high stress ratio where the anomalies due to crack closure are minimized.

5.2 This test method can serve the following purposes:

5.2.1 To establish the influence of fatigue crack growth on the life of components subjected to cyclic loading, provided data are generated under representative conditions and combined with appropriate fracture toughness data (for example, see Test Method E 399), defect characterization data, and stress analysis information (9,10).

NOTE 4—Fatigue crack growth can be significantly influenced by load history. During variable amplitude loading, crack growth rates can be either enhanced or retarded (relative to steady-state, constant-amplitude growth rates at a given  $\Delta K$ ) depending on the specific loading sequence. This complicating factor needs to be considered in using constant-amplitude growth rate data to analyze variable amplitude fatigue problems (11).

5.2.2 To establish material selection criteria and inspection requirements for damage tolerant applications.

5.2.3 To establish, in quantitative terms, the individual and combined effects of metallurgical, fabrication, environmental, and loading variables on fatigue crack growth.

## 6. Apparatus

6.1 *Grips and Fixtures for C(T) Specimens*—A clevis and pin assembly (Fig. 3) is used at both the top and bottom of the specimen to allow in-plane rotation as the specimen is loaded. This specimen and loading arrangement is to be used for tension-tension loading only.

6.1.1 Suggested proportions and critical tolerances of the

clevis and pin are given (Fig. 3) in terms of either the specimen width,  $W$ , or the specimen thickness,  $B$ , since these dimensions may be varied independently within certain limits.

6.1.2 The pin-to-hole clearances illustrated in Fig. 3 are designed to reduce nonlinear load vs. displacement behavior caused by rotation of the specimen and pin (12). Using this arrangement to test materials with relatively low yield strength may cause plastic deformation of the specimen hole. Similarly, when testing high strength materials or when the clevis opening exceeds  $1.05B$  (or both), a stiffer load pin (that is,  $>0.225W$ ) may be required. In these cases, a flat bottom clevis hole or bearings may be used with the appropriate loading pins ( $D = 0.24W$ ) as indicated in Annex A2. The use of high viscosity lubricants such as grease may introduce hysteresis in the load vs. displacement behavior and is not recommended.

6.1.3 Using a 1000-MPa (150-ksi) yield-strength alloy (for example, AISI 4340 steel) for the clevis and pins provides adequate strength and resistance to galling and fatigue.

6.2 *Grips and Fixtures for M(T) Specimens*—The types of grips and fixtures to be used with the M(T) specimens will depend on the specimen width,  $W$ , (defined in Fig. 2), and the loading conditions (that is, either tension-tension or tension-compression loading). The minimum required specimen gage length varies with the type of gripping and is specified so that a uniform stress distribution is developed in the specimen gage length during testing. For testing of thin sheets, constraining plates may be necessary to minimize specimen buckling (see Practice E 561 for recommendations on buckling constraints).

6.2.1 For tension-tension loading of specimens with  $W \leq 75$  mm (3 in.) a clevis and single pin arrangement is suitable for gripping provided that the specimen gage length (that is, the distance between loading pins) is at least  $3W$  (Fig. 2). For this arrangement it is also helpful to either use brass shims between the pin and specimen or to lubricate the pin to prevent fretting-fatigue cracks from initiating at the specimen loading hole. Additional measures which may be taken to prevent cracking at the pinhole include attaching reinforcement plates to the specimen (for example, see Test Method E 338) or employing a “dog bone” type specimen design. In either case, the gage length shall be defined as the uniform section and shall be at least  $1.7W$ .

6.2.2 For tension-tension loading of specimens with  $W \geq 75$  mm (3 in.) a clevis with multiple bolts is recommended (for example, see Practice E 561). In this arrangement, the loads are applied more uniformly; thus, the minimum specimen gage length (that is, the distance between the innermost row of bolt holes) is relaxed to  $1.5W$ .

6.2.3 The M(T) specimen may also be gripped using a clamping device instead of the above arrangements. This type of gripping is necessary for tension-compression loading. An example of a specific bolt and keyway design for clamping M(T) specimens is given in Fig. 4. In addition, various hydraulic and mechanical-wedge systems which supply adequate clamping force are commercially available and may be used. The minimum gage length requirement for clamped specimens is relaxed to  $1.2W$ .

6.3 *Alignment of Grips*—It is important that attention be given to achieving good alignment in the load train through

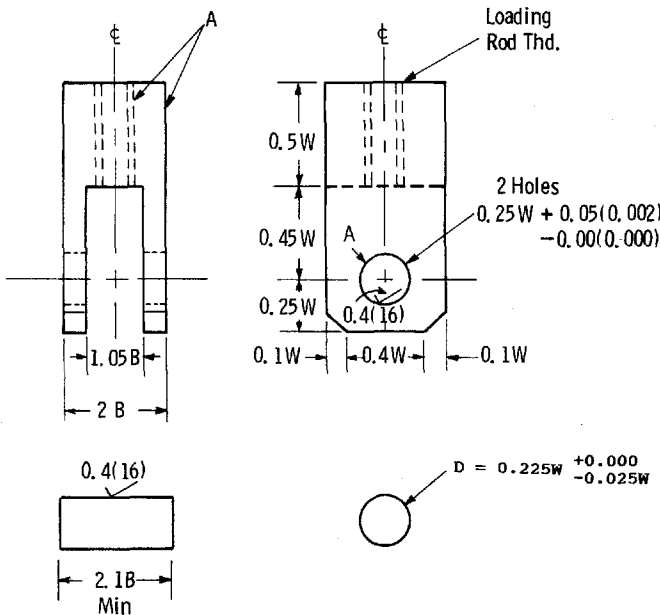

NOTE 1—Dimensions are in millimetres (inches).

NOTE 2—A-surfaces shall be perpendicular and parallel as applicable to within 0.05 mm (0.002 in.), TIR.

FIG. 3 Clevis and Pin Assembly for Gripping C(T) Specimens

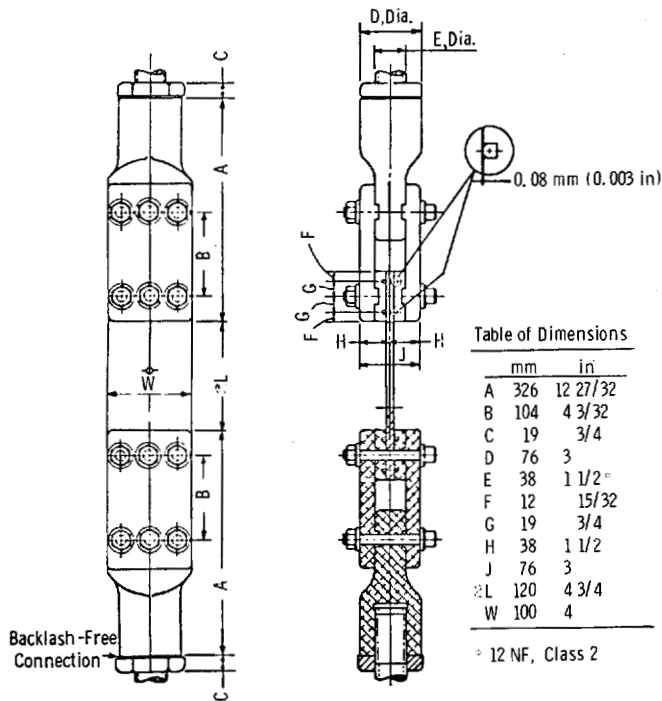

FIG. 4 Example of Bolt and Keyway Assembly for Gripping 100-mm (4-in.) wide M(T) Specimen

careful machining of all gripping fixtures. For tension-tension loading, pin or gimbal connections between the grips and load frame are recommended to achieve loading symmetry. For tension-compression loading the length of the load train (including the hydraulic actuator) should be minimized, and rigid, non-rotating joints should be employed to reduce lateral motion in the load train.

7. Specimen Configuration, Size, and Preparation

7.1 Standard Specimens—The geometry of standard C(T) and M(T) specimens is given in Figs. 1 and 2, respectively. The specific geometry of M(T) specimens depends on the method of gripping as specified in 6.2. Notch and precracking details for both specimens are given in Fig. 5. The C(T) specimen is not recommended for tension-compression testing because of uncertainties introduced into the loading experienced at the crack tip.

NOTE 5—In the near threshold regime (below  $10^{-8}$  m/cycle), one can experience difficulty in meeting the crack symmetry requirements of 8.8.3 when using the M(T) specimen; the C(T) specimen may be an appropriate alternative.

7.1.1 It is required that the machined notch,  $a_n$ , in the C(T) specimen be at least  $0.2W$  in length so that the  $K$ -calibration is not influenced by small variations in the location and dimensions of the loading-pin holes.

7.1.2 The machined notch,  $2a_n$ , in the M(T) specimen shall be centered with respect to the specimen centerline to within  $\pm 0.001W$ . The length of the machined notch in the M(T) specimen will be determined by practical machining considerations and is not restricted by limitations in the  $K$ -calibration.

NOTE 6—It is recommended that  $2a_n$  be at least  $0.2W$  when using the compliance method to monitor crack extension in the M(T) specimen so that accurate crack length determinations can be obtained.

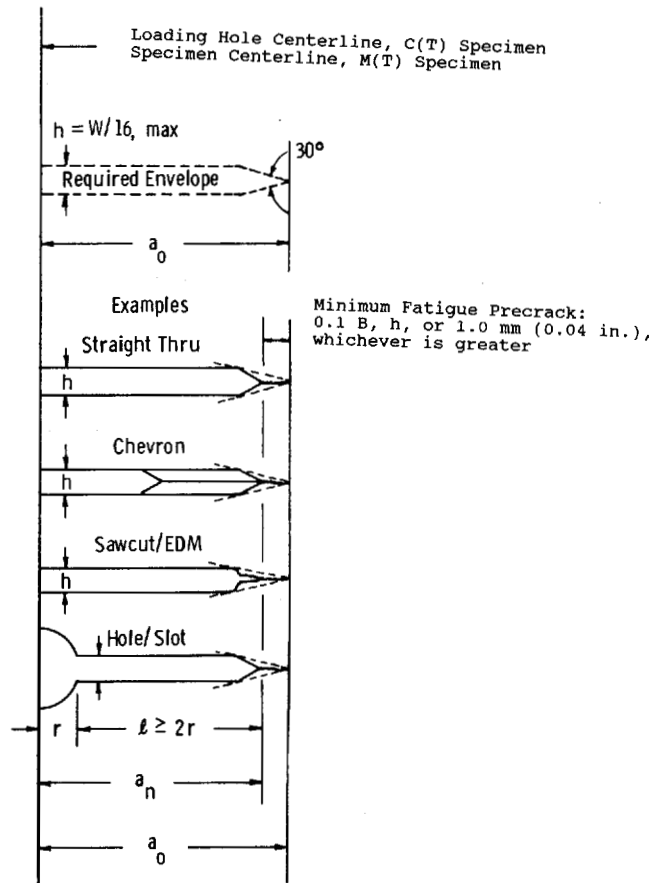

FIG. 5 Notch Details and Minimum Fatigue Precracking Requirements

7.1.3 For both specimens, the thickness,  $B$ , and width,  $W$ , may be varied independently within the following limits, which are based on specimen buckling and through-thickness crack-curvature considerations:

7.1.3.1 For C(T) specimens it is recommended that thickness be within the range  $W/20 \leq B \leq W/4$ . Specimens having thicknesses up to and including  $W/2$  may also be employed; however, data from these specimens will often require through-thickness crack curvature corrections (see 9.1). In addition, difficulties may be encountered in meeting the through-thickness crack straightness requirements of 8.3.4 and 8.8.3.

7.1.3.2 Using the above rationale, the recommended upper limit on thickness in M(T) specimens is  $W/8$ , although  $W/4$  may also be employed. The minimum thickness necessary to avoid excessive lateral deflections or buckling in M(T) specimens is sensitive to specimen gage length, grip alignment, and load ratio,  $R$ . It is recommended that strain gage information be obtained for the particular specimen geometry and loading condition of interest and that bending strains not exceed 5 % of the nominal strain.

7.1.3.3 For specimens removed from material for which complete stress relief is impractical (see 5.1.4), the effect of residual stresses on the crack propagation behavior can be minimized through the careful selection of specimen shape and size. The effect of a through-the-thickness distribution of residual stresses acting perpendicular to the direction of crack growth can be reduced by selecting the specimen  $B/W$

ratio to be small. This choice of specimen shape minimizes crack curvature or other crack front irregularities which confuse the calculation of both  $da/dN$  and  $\Delta K$ . Residual stresses acting parallel to the direction of crack growth can produce moments about the cracktip which also confound test results. These residual stresses can be minimized by selecting symmetrical specimen configurations, that is, the M(T) specimen, for the evaluation of the material's crack growth behavior.

**7.2 Specimen Size**—In order for results to be valid according to this test method it is required that the specimen be predominantly elastic at all values of applied load. The minimum in-plane specimen sizes to meet this requirement are based primarily on empirical results and are specific to specimen configuration (10).

7.2.1 For the C(T) specimen the following is required:

$$(W - a) \geq (4/\pi)(K_{max}/\sigma_{YS})^2$$

where:

$(W - a)$  = specimen's uncracked ligament (Fig. 1), and  
 $\sigma_{YS}$  = 0.2 % offset yield strength determined at the same temperature as used when measuring the fatigue crack growth rate data.

7.2.2 For the M(T) specimen the following is required:

$$(W - 2a) \geq 1.25 P_{max}/(B\sigma_{YS})$$

where:

$(W - 2a)$  = specimen's uncracked ligament (Fig. 2), and  
 $B$  = specimen thickness.

NOTE 7—The size requirements in 7.2 are appropriate for low-strain hardening materials ( $\sigma_{ULT}/\sigma_{YS} \leq 1.3$ ) (13) and for high-strain hardening materials ( $\sigma_{ULT}/\sigma_{YS} \geq 1.3$ ) under certain conditions of load ratio and temperature (14, 15) (where  $\sigma_{ULT}$  is the ultimate tensile strength of the material). However, under other conditions of load ratio and temperature, these same requirements appear to be overly restrictive—that is, they require specimen sizes which are larger than necessary (16, 17). Currently, the conditions giving rise to each of these two regimes of behavior are not clearly defined.

7.2.2.1 An alternative size requirement may be employed for high-strain hardening materials as follows. The uncracked ligament requirement may be relaxed by replacing  $\sigma_{YS}$  with a higher, effective yield strength which accounts for the material strain hardening capacity. For purposes of this test method, this *effective* yield strength, termed flow strength, is defined as follows:

$$\sigma_{FS} = (\sigma_{YS} + \sigma_{ULT})/2$$

However, it should be noted that the use of this alternative size requirement allows mean plastic deflections to occur in the specimen. These mean deflections under certain conditions, as noted previously, can accelerate growth rates by as much as a factor of two. Although these data will generally add conservatism to design or structural reliability computations, they can also confound the effects of primary variables such as specimen thickness (if  $B/W$  is maintained constant), load ratio, and possibly environmental effects. Thus, when the alternative size requirement is utilized, it is important to clearly distinguish between data that meet the yield strength or flow strength criteria. In this way, data will be generated that can be used to formulate a specimen size requirement of general utility.

7.2.3 Figure 6 gives the limiting  $K_{max}$  values, designated  $K_{maxL}$ , which are defined by the above specimen size criteria.

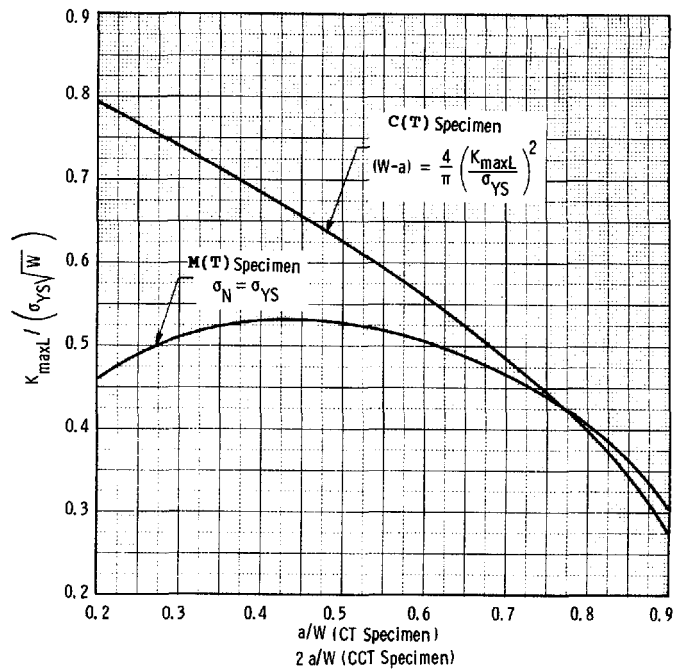

FIG. 6 Normalized Size Requirements for Standard Fatigue Crack Growth Specimens

This information is expressed in dimensionless form so that the curves can be used to calculate either: 1) the value of  $K_{maxL}$  for a given combination of specimen size,  $W$ , and material yield strength ( $\sigma_{YS}$ ), or 2) the minimum specimen size required to obtain valid data up to a desired  $K_{max}$  value for a given material strength level. (However, it should be noted that the desired  $K_{max}$  value cannot be achieved if it is greater than the  $K$  value for unstable fracture.) All values of  $K_{maxL}/(\sigma_{YS} \sqrt{W})$  which fall below the respective curves for the two specimens satisfy the specimen size requirements of this test method.

NOTE 8—When utilizing the alternative size requirement of 7.2.2.1, Fig. 6 is useful as described in 7.2.3 provided  $\sigma_{YS}$  is replaced by  $\sigma_{FS}$ .

**7.3 Notch Preparation**—The machined notch for either of the standard specimens may be made by electrical-discharge machining (EDM), milling, broaching, or sawcutting. The following notch preparation procedures are suggested to facilitate fatigue precracking in various materials:

7.3.1 *Electric Discharge Machining*— $\rho \leq 0.25$  mm (0.010 in.) ( $\rho$  = notch root radius), high-strength steels ( $\sigma_{YS} \geq 1175$  MPa/170 ksi), titanium and aluminum alloys.

7.3.2 *Mill or Broach*— $\rho \leq 0.075$  mm (0.003 in.), low or medium-strength steels ( $\sigma_{YS} \leq 1175$  MPa/170 ksi), aluminum alloys.

7.3.3 *Grind*— $\rho \leq 0.25$  mm (0.010 in.), low or medium-strength steels.

7.3.4 *Mill or Broach*— $\rho \leq 0.25$  mm (0.010 in.), aluminum alloys.

7.3.5 *Sawcut*—Recommended only for aluminum alloys.

7.3.6 Examples of various machined-notch geometries and associated precracking requirements are given in Fig. 5 (see 8.3).

7.3.7 When residual stresses are suspected of being present (see 5.1.4), local displacement measurements made before and after machining the crack starter slot are useful for

detecting the potential magnitude of the effect. A simple mechanical displacement gage can be used to measure distance between two hardness indentations at the mouth of the notch (4). Limited data show that for aluminum alloys when these mechanical displacement measurements change by more than 0.05 mm (0.002 in.), fatigue crack growth rates can be changed significantly.

## 8. Procedure

8.1 *Number of Tests*—At crack growth rates greater than  $10^{-8}$  m/cycle, the within-lot variability (neighboring specimens) of  $da/dN$  at a given  $\Delta K$  typically can cover about a factor of two (18). At rates below  $10^{-8}$  m/cycle, the variability in  $da/dN$  may increase to about a factor of five or more due to increased sensitivity of  $da/dN$  to small variations in  $\Delta K$ . This scatter may be increased further by variables such as microstructural differences, residual stresses, changes in crack tip geometry (crack branching) or near tip stresses as influenced for example by crack roughness or product wedging, load precision, environmental control, and data processing techniques. These variables can take on added significance in the low crack growth rate regime ( $da/dN < 10^{-8}$  m/cycle). In view of the operational definition of the threshold stress-intensity (see 3.3.2 and 9.4), at or near threshold it is more meaningful to express variability in terms of  $\Delta K$  rather than  $da/dN$ . It is good practice to conduct replicate tests; when this is impractical, multiple tests should be planned such that regions of overlapping  $da/dN$  versus  $\Delta K$  data are obtained, particularly under both  $K$ -increasing and  $K$ -decreasing conditions. Since confidence in inferences drawn from the data increases with number of tests, the desired number of tests will depend on the end use of the data.

8.2 *Specimen Measurements*—The specimen dimensions shall be within the tolerances given in Figs. 1 and 2.

8.3 *Fatigue Precracking*—The importance of precracking is to provide a sharpened fatigue crack of adequate size and straightness (also symmetry for the M(T) specimen) which ensures that 1) the effect of the machined starter notch is removed from the specimen  $K$ -calibration, and 2) the effects on subsequent crack growth rate data caused by changing crack front shape or precrack load history are eliminated.

8.3.1 Conduct fatigue precracking with the specimen fully heat treated to the condition in which it is to be tested. The precracking equipment shall be such that the load distribution is symmetrical with respect to the machined notch and  $K_{max}$  during precracking is controlled to within  $\pm 5\%$ . Any convenient loading frequency that enables the required load accuracy to be achieved can be used for precracking. The machined notch plus the precrack must lie within the envelope, shown in Fig. 5, that has as its apex the end of the fatigue precrack. In addition the fatigue precrack shall not be less than  $0.10B$ ,  $h$ , or 1.0 mm (0.040 in.), whichever is greater (Fig. 5).

8.3.2 The final  $K_{max}$  during precracking shall not exceed the initial  $K_{max}$  for which test data are to be obtained. If necessary, loads corresponding to higher  $K_{max}$  values may be used to initiate cracking at the machined notch. In this event, the load range shall be stepped-down to meet the above requirement. Furthermore, it is suggested that reduction in  $P_{max}$  for any of these steps be no greater than 20 % and that

measurable crack extension occur before proceeding to the next step. To avert transient effects in the test data, apply the load range in each step over a crack length increment of at least  $(3/\pi)(K'_{max}/\sigma_{YS})^2$ , where  $K'_{max}$  is the terminal value of  $K_{max}$  from the previous loadstep. If  $P_{min}/P_{max}$  during precracking differs from that used during testing, see the precautions described in 8.5.1.

8.3.3 For the  $K$ -decreasing test procedure, prior loading history may influence near-threshold growth rates despite the precautions of section 8.3.2. It is good practice to initiate fatigue cracks at the lowest stress intensity possible. Precracking growth rates less than  $10^{-8}$  m/cycle are suggested. A compressive load, less than or equal to the precracking load, may facilitate fatigue precracking and may diminish the influence of the  $K$ -decreasing test procedure on subsequent fatigue crack growth rate behavior.

8.3.4 Measure the crack lengths on the front and back surfaces of the specimen to within 0.10 mm (0.004 in.) or  $0.002W$ , whichever is greater. For specimens where  $W > 127$  mm (5 in.), measure crack length to within 0.25 mm (0.01 in.). If crack lengths measured on front and back surfaces differ by more than  $0.25B$ , the pre-cracking operation is not suitable and subsequent testing would be invalid under this test method. In addition for the M(T) specimen, measurements referenced from the specimen centerline to the two cracks (for each crack use the average of measurements on front and back surfaces) shall not differ by more than  $0.025W$ . If the fatigue crack departs more than the allowable limit from the plane of symmetry (see 8.8.3) the specimen is not suitable for subsequent testing. If the above requirements cannot be satisfied, check for potential problems in alignment of the loading system and details of the machined notch.

8.4 *Test Equipment*—The equipment for fatigue testing shall be such that the load distribution is symmetrical to the specimen notch.

8.4.1 Verify the load cell in the test machine in accordance with Practices E 4 and Practice E 467. Conduct testing such that both  $\Delta P$  and  $P_{max}$  are controlled to within  $\pm 2\%$  throughout the test.

8.4.2 An accurate digital device is required for counting elapsed cycles. A timer is a desirable supplement to the counter and provides a check on the counter. Multiplication factors (for example,  $\times 10$  or  $\times 100$ ) should not be used on counting devices when obtaining data at growth rates above  $10^{-5}$  m/cycle since they can introduce significant errors in the growth rate determination.

8.5 *Constant-Load-Amplitude Test Procedure for  $da/dN > 10^{-8}$  m/cycle*—This test procedure is well suited for fatigue crack growth rates above  $10^{-8}$  m/cycle. However, it becomes increasingly difficult to use as growth rates decrease below  $10^{-8}$  m/cycle because of precracking considerations (see 8.3.3). (A  $K$ -decreasing test procedure which is better suited for rates below  $10^{-8}$  m/cycle is provided in 8.6.) When using the constant-load-amplitude procedure it is preferred that each specimen be tested at a constant load range ( $\Delta P$ ) and a fixed set of loading variables (stress ratio and frequency). However, this may not be feasible when it is necessary to generate a wide range of information with a limited number of specimens. When loading variables are changed during a test, potential problems arise from several types of transient

phenomenon (19). The following test procedures should be followed to minimize or eliminate transient effects while using this *K*-increasing test procedure.

8.5.1 If load range is to be incrementally varied it should be done such that  $P_{max}$  is increased rather than decreased to preclude retardation of growth rates caused by overload effects; retardation being a more pronounced effect than accelerated crack growth associated with incremental increase in  $P_{max}$ . Transient growth rates are also known to result from changes in  $P_{min}$  or  $R$ . Sufficient crack extension should be allowed following changes in load to enable the growth rate to establish a steady-state value. The amount of crack growth that is required depends on the magnitude of load change and on the material. An incremental increase of 10 % or less will minimize these transient growth rates.

8.5.2 When environmental effects are present, changes in load level, test frequency, or waveform can result in transient growth rates. Sufficient crack extension should be allowed between changes in these loading variables to enable the growth rate to achieve a steady-state value.

8.5.3 Transient growth rates can also occur, in the absence of loading variable changes, due to long-duration test interruptions, for example, during work stoppages. In this case, data should be discarded if the growth rates following an interruption are less than those before the interruption.

8.6 *K*-Decreasing Procedure for  $da/dN < 10^{-8}$  m/cycle— This procedure is started by cycling at a  $\Delta K$  and  $K_{max}$  level equal to or greater than the terminal precracking values. Subsequently, loads are decreased (shed) as the crack grows, and test data are recorded until the lowest  $\Delta K$  or crack growth rate of interest is achieved. The test may then be

continued at constant load limits to obtain comparison data under *K*-increasing conditions. The *K*-decreasing procedure is not recommended at fatigue crack growth rates above  $10^{-8}$  m/cycle since prior loading history at such associated  $\Delta K$  levels may influence the near-threshold fatigue crack growth rate behavior.

8.6.1 Load shedding during the *K*-decreasing test may be conducted as decreasing load steps at selected crack length intervals, as shown in Fig. 7. Alternatively, the load may be shed in a continuous manner by an automated technique (for example, by use of an analog computer or digital computer, or both) (20).

8.6.2 The rate of load shedding with increasing crack length shall be gradual enough to 1) preclude anomalous data resulting from reductions in the stress-intensity factor and concomitant transient growth rates, and 2) allow the establishment of about five  $da/dN$ ,  $\Delta K$  data points of approximately equal spacing per decade of crack growth rate. The above requirements can be met by limiting the normalized *K*-gradient,  $C = 1/K \cdot dK/da$ , to a value algebraically equal to or greater than  $-0.08 \text{ mm}^{-1}$  ( $-2 \text{ in.}^{-1}$ ). That is:

$$C = \left(\frac{1}{K}\right) \cdot \left(\frac{dK}{da}\right) > -0.08 \text{ mm}^{-1} \text{ } (-2 \text{ in.}^{-1})$$

When loads are incrementally shed, the requirements on *C* correspond to the nominal *K*-gradient depicted in Fig. 7.

NOTE 9—Acceptable values of *C* may depend on load ratio, test material, and environment. Values of *C* algebraically greater than that indicated above have been demonstrated as acceptable for use in decreasing *K* tests of several steel alloys and aluminum alloys tested in laboratory air over a wide range of load ratios (13, 20).

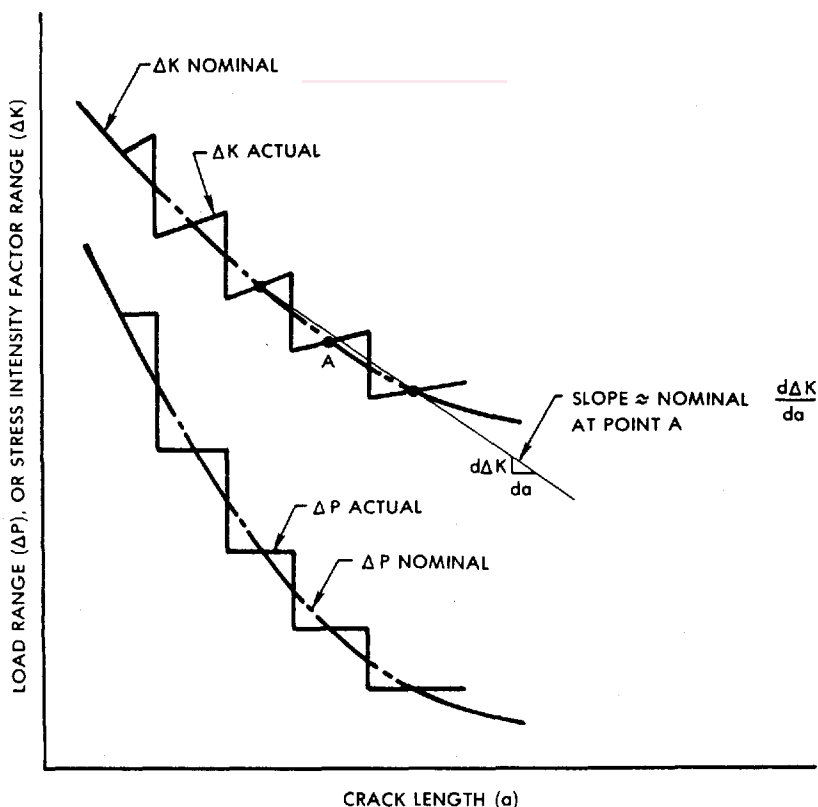

FIG. 7 Typical *K* Decreasing Test by Stepped Load Shedding



8.6.3 If the normalized  $K$ -gradient  $C$  is algebraically less than that prescribed in 8.6.2, the procedure shall consist of decreasing  $K$  to the lowest growth rate of interest followed by a  $K$ -increasing test at a constant  $\Delta P$  (conducted in accordance with 8.5). Upon demonstrating that data obtained using  $K$ -increasing and  $K$ -decreasing procedures are equivalent for a given set of test conditions, the  $K$ -increasing testing may be eliminated from all replicate testing under these same test conditions.

NOTE 10—It is good practice to have  $K$ -decreasing followed by  $K$ -increasing data for the first test of any single material regardless of the  $C$  value used.

8.6.4 It is recommended that the load ratio,  $R$ , and  $C$  be maintained constant during  $K$ -decreasing testing (see section 8.7.1 for exceptions to this recommendation).

8.6.5 The relationships between  $K$  and crack length and between load and crack length for a constant- $C$  test are given as follows:

8.6.5.1  $\Delta K = \Delta K_o \exp[C(a - a_o)]$ , where  $\Delta K_o$  is the initial  $\Delta K$  at the start of the test, and  $a_o$  is the corresponding crack length. Because of the identity given in 3.2 (Note 1), the above relationship is also true for  $K_{\max}$  and  $K_{\min}$ .

8.6.5.2 The load histories for the standard specimens of this test method are obtained by substituting the appropriate  $K$ -calibrations given in 9.3 into the above expression.

8.6.6 When employing step shedding of load, as in Fig. 7, the reduction in  $P_{\max}$  of adjacent load steps shall not exceed 10 % of the previous  $P_{\max}$ . Upon adjustment of maximum load from  $P_{\max 1}$  to a lower value,  $P_{\max 2}$ , a minimum crack extension of 0.50 mm (0.02 in.) is recommended.

8.6.7 When employing continuous shedding of load, the requirement of 8.6.6 is waived. Continuous load shedding is defined as  $(P_{\max 1} - P_{\max 2})/P_{\max 1} \leq 0.02$ .

8.7 *Alternative K-control test procedures*—Ideally, it is desirable to generate  $da/dN$ ,  $\Delta K$  data at  $K$ -gradients independent of the specimen geometry (21). Exercising control over this  $K$ -gradient allows much steeper gradients for small values of  $a/W$  without the undesirable feature of having too steep a  $K$ -gradient at the larger values of  $a/W$  associated with constant amplitude loading. Generating data at an appropriate  $K$ -gradient, using a constant and positive value of the  $K$ -gradient parameter,  $C$ , (see 8.6.2) provides numerous advantages: the test time is reduced; the  $da/dN$ - $\Delta K$  data can be evenly distributed without using variable  $\Delta a$  increments; a wider range of data may be generated without incremental load increases; the  $K$ -gradient is independent of the specimen geometry.

8.7.1 Situations may arise where changing  $\Delta K$  under conditions of constant  $K_{\max}$  or constant  $K_{\text{mean}}$  may be more representative than under conditions of constant  $R$ . The application of the test data should be considered in choosing an appropriate mode of  $K$ -control. For example, a more conservative estimate of near-threshold behavior may be obtained by using this test method. This process effectively measures near-threshold data at a high stress ratio.

8.8 *Measurement of Crack Length*—Make fatigue crack length measurements as a function of elapsed cycles by means of a visual, or equivalent, technique capable of resolving crack extensions of 0.10 mm (0.004 in.), or  $0.002W$ , whichever is greater. For visual measurements, polishing the test area of the specimen and using indirect lighting aid in the

resolution of the crack-tip. It is recommended that, prior to testing, reference marks be applied to the test specimen at predetermined locations along the direction of cracking. Crack length can then be measured using a low power (20 to 50 $\times$ ) traveling microscope. Using the reference marks eliminates potential errors due to accidental movement of the traveling microscope. If precision photographic grids or polyester scales are attached to the specimen, crack length can be determined directly with any magnifying device that gives the required resolution. It is preferred that measurements be made without interrupting the test.

NOTE 11—Interruption of cyclic loading for the purpose of crack length measurement can be permitted providing strict care is taken to avoid introducing any significant extraneous damage (for example, creep deformation) or transient crack extension (for example, growth under static load). The interruption time should be minimized (less than 10 min.) and if a static load is maintained for the purpose of enhanced crack tip resolution, it should be carefully controlled. A static load equal to the fatigue mean load is probably acceptable (with high temperatures and corrosive environments, even mean levels should be questioned) but in no case should the static load exceed the maximum load applied during the fatigue test.

8.8.1 Make crack length measurements at intervals such that  $da/dN$  data are nearly evenly distributed with respect to  $\Delta K$ . The following measurement intervals are recommended according to specimen type:

8.8.1.1 *C(T) Specimen:*

$$\Delta a \leq 0.04W \text{ for } 0.25 \leq a/W \leq 0.40$$

$$\Delta a \leq 0.02W \text{ for } 0.40 \leq a/W \leq 0.60$$

$$\Delta a \leq 0.01W \text{ for } a/W \geq 0.60$$

8.8.1.2 *M(T) Specimen:*

$$\Delta a \leq 0.03W \text{ for } 2a/W < 0.60$$

$$\Delta a \leq 0.02W \text{ for } 2a/W > 0.60$$

8.8.1.3 A minimum  $\Delta a$  of 0.25 mm (0.01 in.) is recommended. However, situations may arise where the  $\Delta a$  needs to be reduced below 0.25 mm (0.01 in.) in order to obtain at least five  $da/dN$ ,  $\Delta K$  data points in the near-threshold regime (see 9.4). In any case, the minimum  $\Delta a$  shall be ten times the crack length measurement precision.

NOTE 12—The crack length measurement precision is herein defined as the standard deviation on the mean value of crack length determined for a set of replicate measurements.

8.8.2 As a rule, crack length measurements should be made on both sides (front and back) of a specimen to ensure that the crack symmetry requirements of 8.8.3 are met. The average value of the measurements (two crack lengths for the C(T) specimen and four crack lengths for the M(T) specimen) should be used in all calculations of growth rate and  $K$ . If crack length measurements are not made on both sides at every crack length interval, the interval of both-side measurement must be reported. Measurement on only one side is permissible only if previous experience with a particular specimen configuration, test material, testing apparatus, and growth rate regime has shown that the crack symmetry requirements are met consistently.

8.8.3 If at any point in the test the crack deviates more than  $\pm 20^\circ$  from the plane of symmetry over a distance of  $0.1W$  or greater, the data are invalid according to this test method. A deviation between  $\pm 10$  and  $\pm 20^\circ$  must be

reported. (See Fig. 8) In addition, data are invalid if (1) crack lengths measured on front and back surfaces differ by more than  $0.25B$ , or (2) for the M(T) specimen, measurements referenced from the specimen centerline to the two cracks (for each crack, use the average of measurements on front and back surfaces) differ by more than  $0.025W$ .

NOTE 13—The requirements on out-of-plane cracking are commonly violated for large-grained or single-crystal materials. In these instances, results from anisotropic, mixed-mode stress analyses may be needed to compute  $K$ ; (for example, see Ref. (22)).

NOTE 14—Crack tip branching has been noted to occur. This characteristic is not incorporated into the computation of  $\Delta K$ . As a result, crack branching, or bifurcating, may be a source of variability in measured fatigue crack growth rate data. Data recorded during branching must be noted as being for a branching crack.

8.8.3.1 If nonvisual methods for crack length measurement are used and nonsymmetric or angled cracking occurs, the nonvisual measurements derived during these periods shall be verified with visual techniques to ensure the requirements of 8.8.3 are satisfied.

**9. Calculation and Interpretation of Results**

9.1 *Crack Curvature Correction*—After completion of testing, examine the fracture surfaces, preferably at two locations (for example, at the precrack and terminal fatigue crack lengths), to determine the extent of through-thickness crack curvature (commonly termed *crack tunneling*). If a crack contour is visible, calculate a three-point, through-thickness average crack length in accordance with Test Method E 399, sections on General Procedure related to Specimen Measurement; specifically the paragraph on crack length measurement. The difference between the average through-thickness crack length and the corresponding crack length recorded during the test (for example, if visual measurements were obtained this might be the average of the surface crack length measurements) is the crack curvature correction.

9.1.1 If the crack curvature correction results in a greater than 5% difference in calculated stress-intensity factor at any crack length, then employ this correction when analyzing the recorded test data.

9.1.2 If the magnitude of the crack curvature correction either increases or decreases with crack length, use a linear

interpolation to correct intermediate data points. Determine this linear correction from two distinct crack contours separated by a minimum spacing of  $0.25W$  or  $B$ , whichever is greater. When there is no systematic variation of crack curvature with crack length, employ a uniform correction determined from an average of the crack contour measurements.

9.1.3 When employing a crack length monitoring technique other than visual, a crack curvature correction is generally incorporated in the calibration of the technique. However, since the magnitude of the correction will probably depend on specimen thickness, the preceding correction procedures may also be necessary.

9.2 *Determination of Crack Growth Rate*—The rate of fatigue crack growth is to be determined from the crack length versus elapsed cycles data ( $a$  versus  $N$ ). Recommended approaches which utilize the secant or incremental polynomial methods are given in Appendix X1. Either method is suitable for the  $K$ -increasing, constant  $\Delta P$  test. For the  $K$ -decreasing tests where load is shed in decremental steps, as in Fig. 7, the secant method is recommended. Where shedding of  $K$  is performed continuously with each cycle by automation, the incremental polynomial technique is applicable. A crack growth rate determination shall not be made over any increment of crack extension which includes a load step.

NOTE 15—Both recommended methods for processing  $a$  versus  $N$  data are known to give the same average  $da/dN$  response. However, the secant method often results in increased scatter in  $da/dN$  relative to the incremental polynomial method, since the latter numerically “smooths” the data (18, 23). This apparent difference in variability introduced by the two methods needs to be considered, especially in utilizing  $da/dN$  versus  $\Delta K$  data in design.

9.3 *Determination of Stress-Intensity Factor Range,  $\Delta K$* —Use the crack length values of 9.1 and Appendix X1 to calculate the stress-intensity range corresponding to a given crack growth rate from the following expressions:

9.3.1 For the C(T) specimen calculate  $\Delta K$  as follows:

$$\Delta K = \frac{\Delta P}{B\sqrt{W}} \frac{(2 + \alpha)}{(1 - \alpha)^{3/2}} (0.886 + 4.64\alpha - 13.32\alpha^2 + 14.72\alpha^3 - 5.6\alpha^4)$$

where  $\alpha = a/W$ ; expression valid for  $a/W \geq 0.2$  (24, 25).

9.3.2 For the M(T) specimen calculate  $\Delta K$  consistent with the definitions of 3.2; that is:

$$\Delta P = P_{max} - P_{min} \text{ for } R > 0$$

$$\Delta P = P_{max} \text{ for } R \leq 0$$

in the following expression (26):

$$\Delta K = \frac{\Delta P}{B} \sqrt{\frac{\pi \alpha}{2W} \sec \frac{\pi \alpha}{2}}$$

where  $\alpha = 2a/W$ ; expression valid for  $2a/W < 0.95$ .

NOTE 16—Implicit in the above expressions are the assumptions that the test material is linear-elastic, isotropic, and homogeneous.

NOTE 17—The above operational definitions do not include potential effects of residual stress or crack closure on the computed  $\Delta K$  value. Autographic load versus crack mouth opening displacement traces are useful for detecting and correcting residual stress/crack closure influences (4).

9.3.3 Check for compliance with the specimen size requirements of 7.2.

9.4 *Determination of a Fatigue Crack Growth Threshold*—The following procedure provides an operational defi-

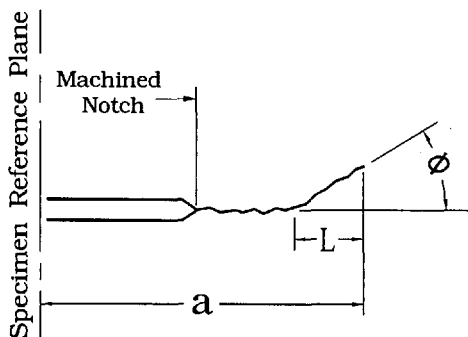

Valid if  $\phi \leq 10^\circ$   
 Report if  $10^\circ < \phi \leq 20^\circ$   
 Invalid if  $\phi > 20^\circ$  for  $L \geq 0.1W$

FIG. 8 Out-of-Plane Cracking Limits

inition of the threshold stress-intensity factor range for fatigue crack growth,  $\Delta K_{th}$ , which is consistent with the general definition of 3.3.2:

9.4.1 Determine the best-fit straight line from a linear regression of  $\log da/dN$  versus  $\log \Delta K$  using a minimum of five  $da/dN$ ,  $\Delta K$  data points of approximately equal spacing between growth rates of  $10^{-9}$  and  $10^{-10}$  m/cycle. Having specified the range of fit in terms of  $da/dN$  requires that  $\log \Delta K$  be the dependent variable in establishing this straight line fit.

NOTE 18—Limitations of the linear regression approach of 9.4.1 are described in Ref (27). Alternative nonlinear approaches and their advantages are also given in Ref (27).

9.4.2 Calculate the  $\Delta K$ -value that corresponds to a growth rate of  $10^{-10}$  m/cycle using the above fitted line; this value of  $\Delta K$  is defined as  $\Delta K_{th}$  according to the operational definition of this test method.

NOTE 19—In the event that lower  $da/dN$  data are generated, the above procedure can be used with the lowest decade of data. This alternative range of fit must then be specified according to 10.1.12.

## 10. Report

10.1 The report shall include the following information:

10.1.1 Specimen type, including thickness,  $B$ , and width,  $W$ . Figures of the specific M(T) specimen design and grips used, and a figure if a specimen type not described in this test method is used shall be provided.

10.1.2 Description of the test machine and equipment used to measure crack length and the precision with which crack length measurements were made.

10.1.3 Test material characterization in terms of heat treatment, chemical composition, and mechanical properties (include at least the 0.2 % offset yield strength and either elongation or reduction in area measured in accordance with Test Methods E 8). Product size and form (for example, sheet, plate, and forging) shall also be identified. Method of stress relief, if applicable, shall be reported. For thermal methods, details of time, temperature and atmosphere. For non-thermal methods, details of loads and frequencies.

10.1.4 The crack plane orientation according to the code given in Test Method E 399. In addition, if the specimen is removed from a large product form, its location with respect to the parent product shall be given.

10.1.5 The terminal values of  $\Delta K$ ,  $R$  and crack length from fatigue precracking. If precrack loads were stepped-down, the procedure employed shall be stated and the amount of crack extension at the final load level shall be given.

10.1.6 Test loading variables, including  $\Delta P$ ,  $R$ , cyclic frequency, and cyclic waveform.

10.1.7 Environmental variables, including temperature, chemical composition, pH (for liquids), and pressure (for gases and vacuum). For tests in air, the relative humidity as determined by Test Method E 337 shall be reported. For tests in inert reference environments, such as dry argon, estimates of residual levels of water and oxygen in the test environment (generally this differs from the analysis of residual impurities in the gas supply cylinder) shall be given. Nominal values for all of the above environmental variables, as well as maximum deviations throughout the duration of testing, shall be reported. Also, the material employed in the

chamber used to contain the environment and steps taken to eliminate chemical/electrochemical reactions between the specimen-environment system and the chamber shall be described.

10.1.8 Analysis methods applied to the data, including the technique used to convert  $a$  versus  $N$  to  $da/dN$ , specific procedure used to correct for crack curvature, and magnitude of crack curvature correction.

10.1.9 The specimen  $K$ -calibration and size criterion to ensure predominantly elastic behavior (for specimens not described in this test method).

10.1.10  $da/dN$  as a function of  $\Delta K$  shall be plotted. (It is recommended that  $\Delta K$  be plotted on the abscissa and  $da/dN$  on the ordinate. Log-log coordinates are commonly used. For optimum data comparisons, the size of the  $\Delta K$ -log cycles should be two or three times larger than  $da/dN$ -log cycles.) All data that violate the size requirements of 7.2 shall be identified; state whether  $\sigma_{YS}$  or  $\sigma_{FS}$  was used to determine specimen size.

10.1.11 Description of any occurrences that appear to be related to anomalous data (for example, transience following test interruptions or changes in loading variables).

10.1.12 For  $K$ -decreasing tests, report  $C$  and initial values of  $K$  and  $a$ . Indicate whether or not the  $K$ -decreasing data were verified by  $K$ -increasing data. For near-threshold growth rates, report  $\Delta K_{th}$ , the equation of the fitted line (see 9.4) used to establish  $\Delta K_{th}$ , and any procedures used to establish  $\Delta K_{th}$  which differ from the operational definition of 9.4. Also report the lowest growth rate used to establish  $\Delta K_{th}$  using the operational definition of 9.4. It is recommended that these values be reported as  $\Delta K_{th}(x)$  where  $x$  is the aforementioned lowest growth rate in m/cycle.

10.1.13 It is desirable, but not required, to tabulate test results. When using this test method of presentation, the following information shall be tabulated for each test:  $a$ ,  $N$ ,  $\Delta K$ ,  $da/dN$ , and, where applicable, the test variables of 10.1.3, 10.1.6, and 10.1.7. Also, all data determined from tests on specimens that violate the size requirements of 7.2 shall be identified; state whether  $\sigma_{YS}$  or  $\sigma_{FS}$  was used to determine specimen size.

## 11. Precision and Bias

11.1 *Precision*—The precision of  $da/dN$  versus  $\Delta K$  is a function of inherent material variability, as well as errors in measuring crack length and applied load. The required loading precision of 8.4.1 can be readily obtained with modern closed-loop electrohydraulic test equipment and results in a  $\pm 2$  % variation in the applied  $\Delta K$ ; this translates to a  $\pm 4$  % to  $\pm 10$  % variation in  $da/dN$ , at a given  $\Delta K$ , for growth rates above the near-threshold regime. However, in general, the crack length measurement error makes a more significant contribution to the variation in  $da/dN$ , although this contribution is difficult to isolate since it is coupled to the analysis procedure for converting  $a$  versus  $N$  to  $da/dN$ , and to the inherent material variability. Nevertheless, it is clear that the overall variation in  $da/dN$  is dependent on the ratio of crack length measurement interval to measurement error (23, 28). Furthermore, an optimum crack length measurement interval exists due to the fact that the interval should be large compared to the measurement error (or precision), but small compared to the  $K$ -gradient of the test