



Standard Test Method for Determining Plane-Strain Crack-Arrest Fracture Toughness, K_{Ia} , of Ferritic Steels¹

This standard is issued under the fixed designation E 1221; the number immediately following the designation indicates the year of original adoption or, in the case of revision, the year of last revision. A number in parentheses indicates the year of last reapproval. A superscript epsilon (ϵ) indicates an editorial change since the last revision or reapproval.

1. Scope

1.1 This test method employs a side-grooved, crack-line-wedge-loaded specimen to obtain a rapid run-arrest segment of flat-tensile separation with a nearly straight crack front. This test method provides a static analysis determination of the stress intensity factor at a short time after crack arrest. The estimate is denoted K_a . When certain size requirements are met, the test result provides an estimate, termed K_{Ia} , of the plane-strain crack-arrest toughness of the material.

1.2 The specimen size requirements, discussed later, provide for in-plane dimensions large enough to allow the specimen to be modeled by linear elastic analysis. For conditions of plane-strain, a minimum specimen thickness is also required. Both requirements depend upon the crack arrest toughness and the yield strength of the material. A range of specimen sizes may therefore be needed, as specified in this test method.

1.3 If the specimen does not exhibit rapid crack propagation and arrest, K_a cannot be determined.

1.4 Values stated in inch-pound units are to be regarded as the standards. SI units are provided for information only.

1.5 *This standard does not purport to address all of the safety concerns, if any, associated with its use. It is the responsibility of the user of this standard to establish appropriate safety and health practices and determine the applicability of regulatory limitations prior to use.*

2. Referenced Documents

2.1 ASTM Standards:

E 8 Test Methods for Tension Testing of Metallic Materials²

E 23 Test Methods for Notched Bar Impact Testing of Metallic Materials²

E 208 Test Method for Conducting Drop-Weight Test to Determine Nil-Ductility Transition Temperature of Ferritic Steels²

E 399 Test Method for Plane-Strain Fracture Toughness of Metallic Materials²

E 616 Terminology Relating to Fracture Testing²

¹ This test method is under the jurisdiction of ASTM Committee E-8 on Fracture Testing and is the direct responsibility of Subcommittee E08.07 on Linear-Elastic Fracture.

Current edition approved June 10, 1996. Published August 1996. Originally published as E 1221 – 88. Last previous edition E 1221 – 88.

² Annual Book of ASTM Standards, Vol 03.01.

E 1304 Test Method for Plane-Strain (Chevron Notch) Fracture Toughness of Metallic Materials²

3. Terminology

3.1 Definitions:

3.1.1 Definitions in Terminology E 616 are applicable to this test method.

3.2 Definitions of Terms Specific to This Standard:

3.2.1 *conditional value of the plane-strain crack-arrest fracture toughness, K_{Qa} (FL^{-3/2})*—the conditional value of K_{Ia} calculated from the test results and subject to the validity criteria specified in this test method.

3.2.1.1 *Discussion*—In this test method, side-grooved specimens are used. The calculation of K_{Qa} is based upon measurements of both the arrested crack length and of the crack-mouth opening displacement prior to initiation of a fast-running crack and shortly after crack arrest.

3.2.2 *crack-arrest fracture toughness, K_a (FL^{-3/2})*—the value of the stress intensity factor shortly after crack arrest.

3.2.2.1 *Discussion*—The in-plane specimen dimensions must be large enough for adequate enclosure of the crack-tip plastic zone by a linear-elastic stress field.

3.2.3 *plane-strain crack-arrest fracture toughness, K_{Ia} (FL^{-3/2})*—the value of crack-arrest fracture toughness, K_a , for a crack that arrests under conditions of crack-front plane-strain.

3.2.3.1 *Discussion*—The requirements for attaining conditions of crack-front plane-strain are specified in the procedures of this test method.

3.2.4 *stress intensity factor at crack initiation, K_o (FL^{-3/2})*—the value of K at the onset of rapid fracturing.

3.2.4.1 *Discussion*—In this test method, only a nominal estimate of the initial driving force is needed. For this reason, K_o is calculated on the basis of the original (machined) crack (or notch) length and the crack-mouth opening displacement at the initiation of a fast-running crack.

4. Summary of Test Method

4.1 This test method estimates the value of the stress intensity factor, K , at which a fast running crack will arrest. This test method is made by forcing a wedge into a split-pin, which applies an opening force across the crack starter notch in a modified compact specimen, causing a run-arrest segment of crack extension. The rapid run-arrest event suggests need for a

dynamic analysis of test results. However, experimental observations **(1, 2)**³ indicate that, for this test method, an adjusted static analysis of test results provides a useful estimate of the value of the stress intensity factor at the time of crack arrest.

4.2 Calculation of a nominal stress intensity at initiation, K_o , is based on measurements of the machined notch length and the crack-mouth opening displacement at initiation. The value of K_o is based on measurements of the arrested crack length and the crack-mouth opening displacements prior to initiation and shortly after crack arrest.

5. Significance and Use

5.1 In structures containing gradients in either toughness or stress, a crack may initiate in a region of either low toughness or high stress, or both, and arrest in another region of either higher toughness or lower stress, or both. The value of the stress intensity factor during the short time interval in which a fast-running crack arrests is a measure of the ability of the material to arrest such a crack. Values of the stress intensity factor of this kind, which are determined using dynamic methods of analysis, provide a value for the crack-arrest fracture toughness which will be termed K_A in this discussion. Static methods of analysis, which are much less complex, can often be used to determine K at a short time (1 to 2 ms) after crack arrest. The estimate of the crack-arrest fracture toughness obtained in this fashion is termed K_a . When macroscopic dynamic effects are relatively small, the difference between K_A and K_a is also small **(1-4)**. For cracks propagating under conditions of crack-front plane-strain, in situations where the dynamic effects are also known to be small, K_{Ia} determinations using laboratory-sized specimens have been used successfully to estimate whether, and at what point, a crack will arrest in a structure **(5, 6)**. Depending upon component design, loading compliance, and the crack jump length, a dynamic analysis of a fast-running crack propagation event may be necessary in order to predict whether crack arrest will occur and the arrest position. In such cases, values of K_{Ia} determined by this test method can be used to identify those values of K below which the crack speed is zero. More details on the use of dynamic analyses can be found in Ref **(4)**.

5.2 This test method can serve at least the following additional purposes:

5.2.1 In materials research and development, to establish in quantitative terms significant to service performance, the effects of metallurgical variables (such as composition or heat treatment) or fabrication operations (such as welding or forming) on the ability of a new or existing material to arrest running cracks.

5.2.2 In design, to assist in selection of materials for, and determine locations and sizes of, stiffeners and arrestor plates.

6. Apparatus

6.1 The procedure involves testing of modified compact specimens that have been notched by machining. To minimize the introduction of additional energy into the specimen during

the run-arrest event, the loading system must have a low compliance compared with the test specimen. For this reason a wedge and split-pin assembly is used to apply a load on the crack line. This loading arrangement does not permit easy measurement of opening loads. Consequently, opening displacement measurements in conjunction with crack size and compliance calibrations are used for calculating K_o and K_a .

6.2 Loading Arrangement:

6.2.1 A typical loading arrangement is shown in Fig. 1. The specimen is placed on a support block whose thickness should be adequate to allow completion of the test without interference between the wedge and the lower crosshead of the testing machine. The support block should contain a hole that is aligned with the specimen hole, and whose diameter should be between 1.05 and 1.15 times the diameter of the hole in the specimen. The load that forces the wedge into the split-pin is transmitted through a load cell.

6.2.1.1 The surfaces of the wedge, split-pin, support block, and specimen hole should be lubricated. Lubricant in the form of thin (0.005 in. or 0.13 mm) strips of TFE-fluorocarbon is preferred. Molybdenum disulfide (both dry and in a grease vehicle) and high-temperature lubricants can also be used.

6.2.1.2 A low-taper-angle wedge and split-pin arrangement is used. If grease or dry lubricants are used, a matte finish (grit blasted) on the sliding surfaces may be helpful in avoiding galling. The split-pin must be long enough to contact the full

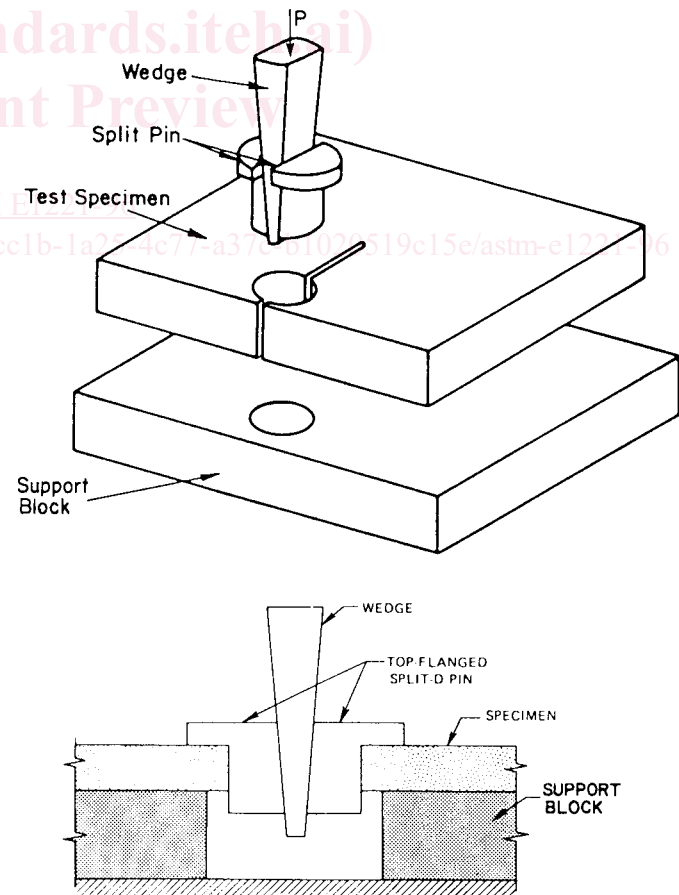

FIG. 1 Schematic Pictorial and Sectional Views Showing the Standard Arrangement of the Wedge and Split-Pin Assembly, the Test Specimen, and the Support Block

³ The boldface numbers in parentheses refer to the list of references at the end of this test method.

specimen thickness, and the radius must be large enough to avoid plastic indentations of the test specimen. In all cases it is recommended that the diameter of the split-pin should be 0.005 in. (0.13 mm) less than the diameter of the specimen hole. The wedge must be long enough to develop the maximum expected opening displacement. Any air or oil hardening tool steel is suitable for making the wedge and split-pins. A hardness in the range from $R_C 45$ to $R_C 55$ has been used successfully. With the recommended wedge angle and proper lubrication, a loading machine producing $1/5$ to $1/10$ the expected maximum opening load is adequate. The dimensions of a wedge and split-pin assembly suitable for use with a 1.0-in. (25.4-mm) diameter loading hole are shown in Fig. 2. The dimensions should be scaled when other hole diameters are used. A hole diameter of 1.0 in. has been found satisfactory for specimens having $5 < W < 6.7$ in. ($125 < W < 170$ mm).

NOTE 1—Specimens tested with the arrangement shown in Fig. 1 may not exhibit an adequate segment of run-arrest fracturing, for example, at testing temperatures well above the NDT temperature. In these circumstances, the use of the loading arrangement shown in Fig. 3 has been found to be helpful (2, 7) and may be employed.

6.3 Displacement Gages—Displacement gages are used to measure the crack-mouth opening displacement at $0.25W$ from the load-line. Accuracy within 2% over the working range is required. Either the gage recommended in Test Method E 399 or a similar gage modified to accommodate conical seats is satisfactory. It is necessary to attach the gage in a fashion such that seating contact with the specimen is not altered by the jump of the crack. Two methods that have proven satisfactory

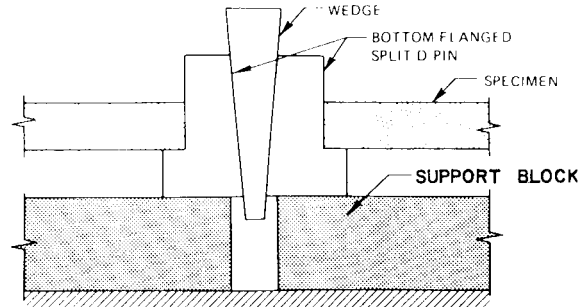

FIG. 3 Sectional View of a Loading Arrangement That May Be Helpful When Testing Specimens at Higher Temperatures

for doing this are shown in Fig. 4. Other gages can be used so long as their accuracy is within 2%.

7. Specimen Configuration, Dimensions, and Preparation

7.1 Standard Specimen:

7.1.1 The configuration of a compact-crack-arrest (CCA) specimen that is satisfactory for low- and intermediate-strength steels is shown in Fig. 5. (In this context, an intermediate-strength steel is considered to be one whose static yield stress, σ_{YS} , is of the order of 100 ksi (700 MPa) or less.)

7.1.1.1 The thickness, B , shall be either full product plate thickness or a thickness sufficient to produce a condition of plane-strain, as specified in 9.3.3.

7.1.1.2 Side grooves of depth $B/8$ per side shall be used. For alloys that require notch-tip embrittlement (see 7.1.3.2) the side grooves should be introduced after deposition of the brittle weld.

7.1.1.3 The specimen width, W , shall be within the range $2B \leq W \leq 8B$.

7.1.1.4 The displacement gage shall measure opening displacements at an offset from the load line of $0.25W$, away from the crack tip.

7.1.2 Specimen Dimensions:

7.1.2.1 In order to limit the extent of plastic deformation in the specimen prior to crack initiation, certain size requirements must be met. These requirements depend upon the material yield strength. They also depend upon K_{Ic} , and therefore the K_{Ic} needed to achieve an appropriate run-arrest event.

7.1.2.2 The in-plane specimen dimensions must be large enough to allow for the linear elastic analysis employed by this test method. These requirements are given in 9.3.2 and 9.3.4, in terms of allowable crack jump lengths.

7.1.2.3 For a test result to be termed plane-strain (K_{Ic}) by this test method, the specimen thickness, B , should meet the requirement given in 9.3.3.

7.1.3 Starting Notch:

7.1.3.1 The function of the starting notch is to produce crack initiation at an opening displacement (or wedging force) that will permit an appropriate length of crack extension prior to crack arrest. Different materials require different starter notch preparation procedures.

7.1.3.2 The recommended starter notch for low- and intermediate-strength steels is a notched brittle weld, as shown in Fig. 6. It is produced by depositing a weld across the specimen thickness. Guidelines on welding procedures are given in Appendix X1.

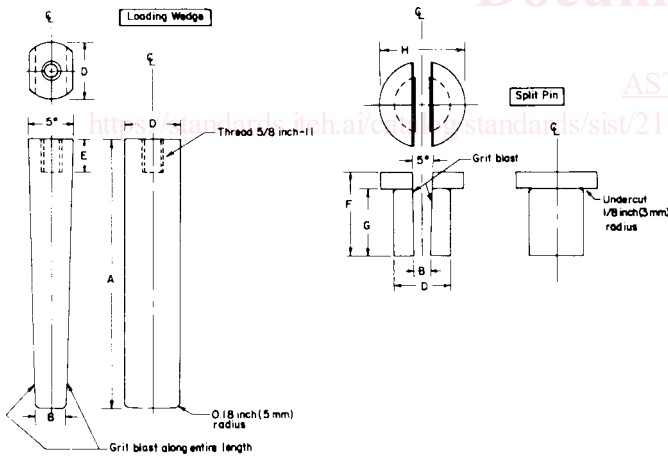

	in.	mm
A	8.00	203
B	0.33	8.4
D	0.99	25.1
E	1.00	25.4
F	2.25	57.2
G	2.00	50.8
H	1.50	38.1

NOTE 1—The dimensions given are suitable for use with a 1.0 in. (25.4 mm) diameter loading hole in a 2.0 in. (50.8 mm) thick test specimen. These dimensions should be scaled appropriately when other hole diameters and specimen thicknesses are used.

FIG. 2 Suggested Geometry and Dimensions of a Wedge and Split-Pin Assembly

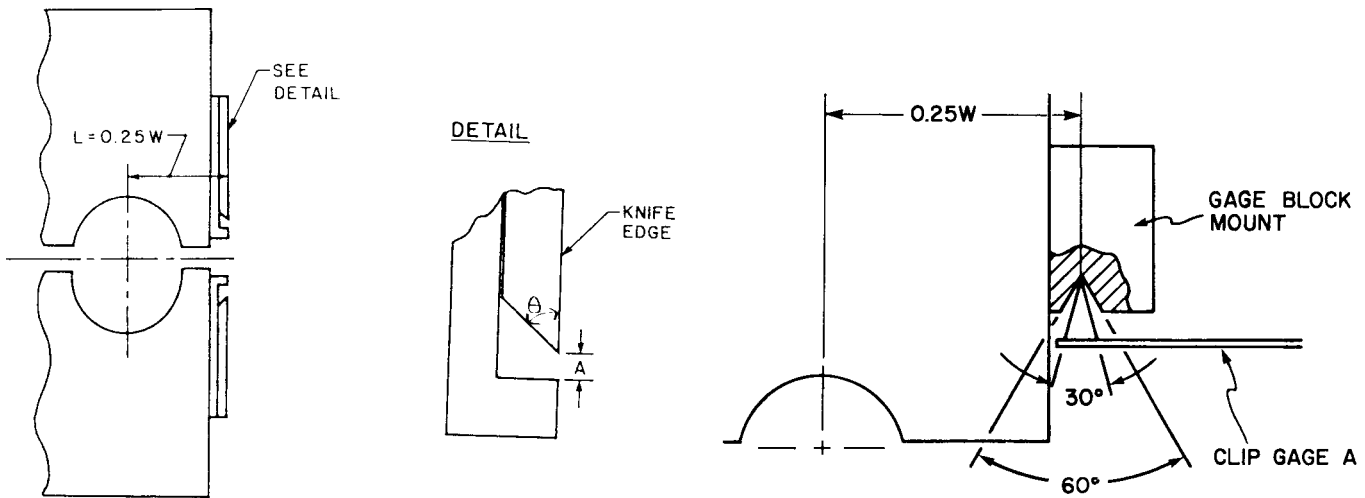

NOTE 1— Dimension A should be 0.002–0.010 in. (0.05–0.25 mm) less than the thickness of the clip gage arm.
 NOTE 2—The knife edge can be attached to the specimen with mechanical fasteners or adhesives.
 NOTE 3—The clip gage is installed by sliding it into the gap.

FIG. 4 Two Alternative Clip Gage Seating Arrangements Using Knife Edges and Using Conical Mounts

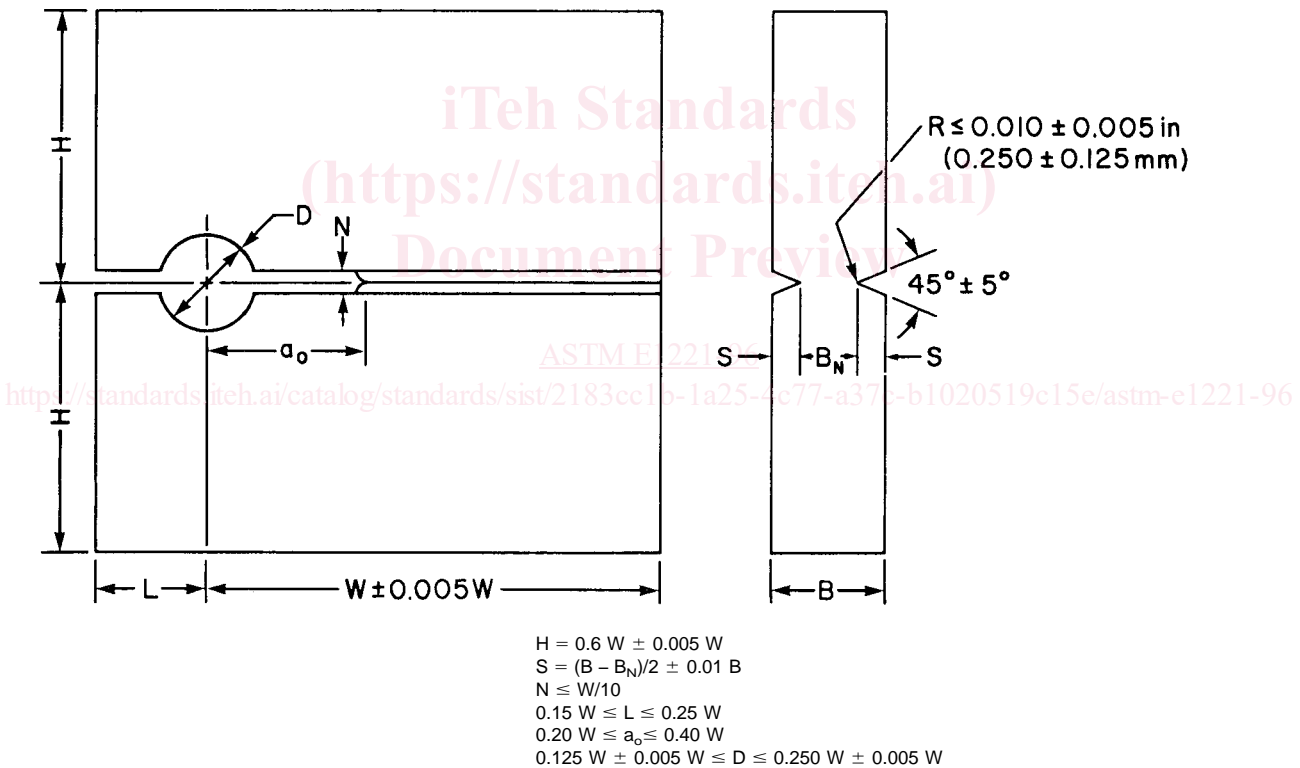

FIG. 5 Geometry and Dimensions of a Crack-Line-Wedge-Loaded Compact-Crack-Arrest (CCA) Test Specimen that is Satisfactory for Low and Medium Strength Steels

7.1.3.3 Alternative crack starter configurations (8) and embrittlement methods may also be used. Examples of both alternative configurations and alternative test methods are also described in Appendix X1.

7.1.3.4 While it is expected that a_o values for the starting notch will typically lie in the range $0.30 W \leq a_o \leq 0.40 W$, it is sometimes useful to utilize values as low as $0.20 W$. The lower initial value of a_o/W results in a greater and quicker drop in the crack driving force as the crack extends. This may aid in

arresting the running crack at a shorter final crack length and could be useful for conditions where the crack extension is too great with larger initial a_o/W values.

8. Procedure

8.1 *Number of Tests*—It is recommended that at least three valid test results be obtained at a single test temperature.

8.2 *Specimen Measurement*—Measure the specimen thickness, B , and the crack plane thickness, B_N , to $\pm 1\%$ of B .

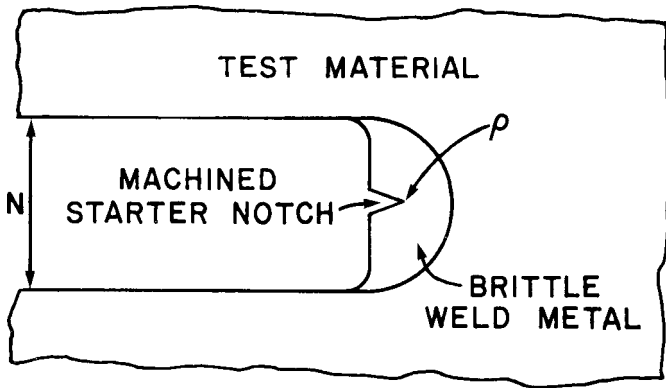

NOTE 1—Dimension *N* must be large enough to allow entry of the welding electrode being used.

FIG. 6 Details of the Notched Brittle Weld that is Recommended for Use as a Crack Starter for Low and Medium Strength Steels

Measure the specimen width, *W*, to $\pm 1\%$ of *W*.

8.3 Temperature Control and Measurement:

8.3.1 Specimens may be heated or cooled to the selected test temperature by any appropriate method. A method that has been used successfully for elevated-temperature tests employs electric-resistance heating tapes in combination with a variable power source. Tests at subambient temperatures have been conducted using cooling coils embedded in the specimen support block (see Fig. 7); a controlled flow of liquid nitrogen or other suitable coolant through the cooling coils permits low temperatures to be reached without difficulty. To minimize temperature gradients through the specimen thickness, it is necessary to surround the specimen with a good thermal insulator. Prior to starting the test, the specimen should be held at the test temperature for a time sufficient to allow the specimen to attain a uniform temperature (to within 5°F (3°C)).

8.3.2 Measure the specimen temperature with a thermocouple welded to the top surface of the specimen at a location near the side groove, about 1 in. (25 mm) ahead of the starter notch. In reporting the test results, the test temperature shall be the temperature measured on the specimen at the time of the rapid run-arrest event.

8.4 Loading Procedure:

8.4.1 The test method calls for the use of a cyclic loading technique. In this technique, load is applied to the wedge until a rapid crack initiates, or until the crack-mouth opening displacement (measured by the clip gage) reaches a predetermined value. If a rapid fracture has not initiated prior to the recommended maximum displacement being reached, the specimen is unloaded until the wedge loses contact with the split-pin. The specimen is then reloaded in the same manner as before and load application is once again terminated either by initiation of a rapid crack or upon the opening displacement reaching a specified value. Successively higher values of the recommended maximum opening displacement are allowed on each loading cycle, until a rapid crack initiates or until the test is discontinued.

8.4.2 The loading technique of this test method does not allow direct measurement of the opening loads applied to the specimen by the wedge and split-pin assembly. The load applied to the specimen is therefore obtained from measurements of the crack-mouth opening displacement. Components of the opening displacement that do not contribute to the opening load can occur. These have their origin primarily in seating of the load train and clip gage, local cracking in the brittle weld, and interference with crack closure due to incomplete strain reversal in the plastic zone near the root of the starter notch. The purpose of the cyclic loading technique is to identify and estimate the magnitude of these contributions.

8.4.3 The effects of load train seating and weld bead

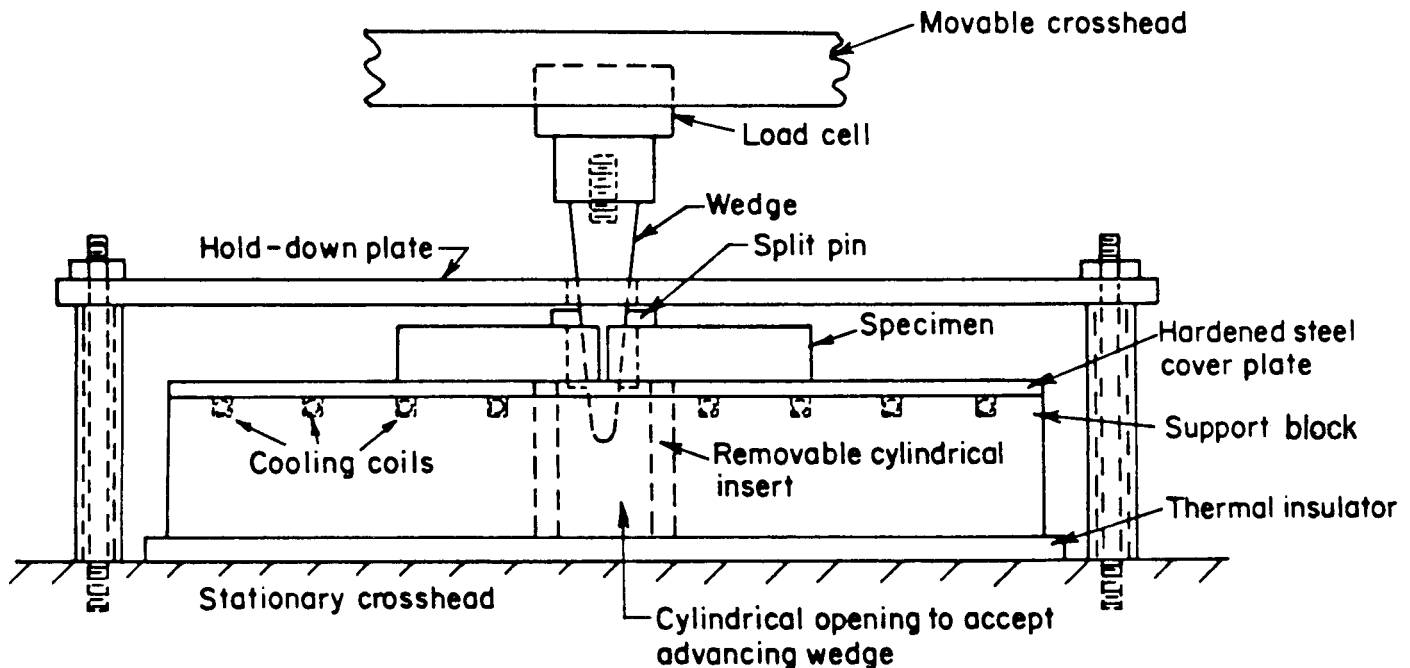

FIG. 7 Schematic Illustration of a Loading Arrangement that Facilitates Wedge Extraction When Using the Cyclic Loading Technique

cracking can essentially be limited to the first loading cycle by an appropriate limit on the maximum opening displacement imposed in that cycle. This limit is designed to keep the first loading cycle linear elastic in a global sense. These influences can then be eliminated, with some degree of conservatism, by excluding the zero-load displacement offset recorded at the end of the first loading cycle from the displacement used to calculate K_a .

8.4.4 The second undesirable contribution to the total measured crack opening displacement is due to the local yielding that occurs around the root of the starter notch prior to initiation of a rapid fracture. The formation and growth of this plastic zone can be regarded as being mainly responsible for the zero-load displacement offsets that are recorded after completion of the first loading cycle, that is, between Cycles 2 and 3, 3 and 4, etc. The influence of this effect could be eliminated in its entirety by excluding all of the zero-load offset in opening displacement measured prior to the start of the loading cycle during which the run-arrest event occurs. However, there is evidence to suggest that such a step may be overly conservative. Model tests have shown that, when the plastic zone is well enclosed by the linear elastic stress field in the specimen, nearly all of the offset in the zero-load displacement is recovered if the plastic zone is severed by a saw cut or by a brittle crack (9). The degree to which this component of the strain energy stored in the specimen is recovered in time to influence the run-arrest behavior of the rapid crack is unclear at the present time. The K -calculation procedure of this test method therefore avoids the extremes of excluding all or none of the zero-load displacement offsets which accumulate in the second and subsequent loading cycles, and excludes one half of these effects.

8.4.5 An autographic record of wedge-load versus crack-mouth-opening-displacement should be obtained. The recorder should not be re-zeroed between loading cycles since knowledge of the accumulated zero-load displacement offset is desired. It could also be useful to obtain information about the final segment of the opening-displacement versus time record on an oscillograph or other high-rate recording device. This would provide additional information about the nature of the run-arrest event.

8.4.6 Apply load to the wedge until the crack-mouth-opening-displacement measured by the clip gage reaches the recommended maximum value given by:

$$[(\delta_o)_1]_{\max} = \frac{0.69 \sigma_{YS} W \sqrt{B_N/B}}{E f(a_o/W)} \quad (1)$$

where:

σ_{YS} = static yield strength of the specimen material (or, in the case of the duplex specimen, of the crack-starter-section material).

The other terms are as defined in 9.2. The testing machine should be operated in displacement control, with a free-running crosshead speed of 0.1 to 0.5 in./min (2 to 12 mm/min).

NOTE 2—Rapid fracture initiation on the first loading cycle is unlikely in the brittle weld CCA specimen. However, if a run-arrest event does occur, proceed with the calculations of K_o and K_a in the same manner as if sequential load-unload cycling had been used. In subsequent tests of

replicate specimens, the first cycle displacement limit should be reduced sufficiently so that the first loading cycle can be completed without intervention of a rapid fracture.

8.4.7 Unload the specimen by extracting the wedge in preparation for a second loading cycle. The clip gage should remain in place during unloading and wedge removal to maintain a record of the displacement offset that occurs upon a return to zero load.

NOTE 3—Wedge extraction and cyclic loading can be simplified greatly by the use of the arrangement shown schematically in Fig. 7. Key features include a hold-down plate and a wedge that is fastened to the loading ram. However, the hold-down plate may not be required when using lubricant in the form of TFE-fluorocarbon strips (see 6.2.1.1).

8.4.8 Without re-zeroing the recorder, reinsert and apply load to the wedge at the same displacement rate as on the first cycle. Continue loading until a rapid crack jump occurs or until the displacement measured with the clip gage reaches a predetermined value. The recommended maximum opening displacement on the second and subsequent cycles can be calculated from

$$[(\delta_o)_n]_{\max} = [1.0 + 0.25(n - 1)] \left[\frac{0.69 \sigma_{YS} W \sqrt{B_N/B}}{E f(a_o/W)} \right] \quad (2)$$

where:

n = cycle number.

The other terms are the same as in (Eq 1). If an unstable crack is not initiated upon reaching the prescribed displacement limit, again unload and extract the wedge as specified in 8.4.7. Label the load/displacement record with the appropriate cycle number and repeat 8.4.8.

NOTE 4—If a large number of load/unload cycles are required, it may be necessary to relubricate the wedge and split-pin assembly. Increased friction will be indicated by an increased slope in the load-displacement record and the need for large reverse loads to extract the wedge.

8.4.9 To measure K_a , a segment of unstable crack extension must occur. The occurrence of unstable crack extension will normally be apparent to the operator, both audibly and as an abrupt load drop on the test record. (In the brittle weld CCA specimen, a load drop of 50 to 60 % has been found to indicate that a sufficient length of unstable fracturing has occurred.) After the event, the operator should remove the load on the wedge to avoid further crack propagation.

8.4.10 If on subsequent loading cycles, it is observed that attempts to increase the opening displacement are accompanied by a decrease in the applied wedge load, that is, stable tearing is occurring, it is unlikely that the specimen will exhibit rapid run-arrest fracturing. It is recommended that under these circumstances, the test be discontinued. It may be helpful at this point to remachine the specimen to remove the weld bead and the material ahead of the starter notch that has been subjected to plastic deformation. A fresh starter notch can then be prepared and the specimen retested at a lower temperature (35 to 70°F (20 to 40°C) lower) in an attempt to obtain useful data from the specimen.

NOTE 5—A displacement limit beyond which the specimen is unlikely to give successful results can be estimated from the following equation: