



Designation: G 65 – 00

Standard Test Method for Measuring Abrasion Using the Dry Sand/Rubber Wheel Apparatus¹

This standard is issued under the fixed designation G 65; the number immediately following the designation indicates the year of original adoption or, in the case of revision, the year of last revision. A number in parentheses indicates the year of last reapproval. A superscript epsilon (ε) indicates an editorial change since the last revision or reapproval.

e¹ NOTE—This standard was previously named in error as G 65–00a

1. Scope

1.1 This test method covers laboratory procedures for determining the resistance of metallic materials to scratching abrasion by means of the dry sand/rubber wheel test. It is the intent of this test method to produce data that will reproducibly rank materials in their resistance to scratching abrasion under a specified set of conditions.

1.2 Abrasion test results are reported as volume loss in cubic millimetres for the particular test procedure specified. Materials of higher abrasion resistance will have a lower volume loss.

NOTE 1—In order to attain uniformity among laboratories, it is the intent of this test method to require that volume loss due to abrasion be reported only in the metric system as cubic millimetres. $1 \text{ mm}^3 = 6.102 \times 10^{-5} \text{ in}^3$.

1.3 This test method covers five recommended procedures which are appropriate for specific degrees of wear resistance or thicknesses of the test material.

1.3.1 *Procedure A*—This is a relatively severe test which will rank metallic materials on a wide volume loss scale from low to extreme abrasion resistance. It is particularly useful in ranking materials of medium to extreme abrasion resistance.

1.3.2 *Procedure B*—A short-term variation of Procedure A. It may be used for highly abrasive resistant materials but is particularly useful in the ranking of medium- and low-abrasive-resistant materials. Procedure B should be used when the volume-loss values developed by Procedure A exceeds 100 mm^3 .

1.3.3 *Procedure C*—A short-term variation of Procedure A for use on thin coatings.

1.3.4 *Procedure D*—This is a lighter load variation of Procedure A which is particularly useful in ranking materials of low-abrasion resistance. It is also used in ranking materials of

a specific generic type or materials which would be very close in the volume loss rates as developed by Procedure A.

1.3.5 *Procedure E*—A short-term variation of Procedure B that is useful in the ranking of materials with medium- or low-abrasion resistance.

1.4 *This standard does not purport to address the safety concerns, if any, associated with its use. It is the responsibility of the user of this standard to establish appropriate safety and health practices and determine the applicability of regulatory limitations prior to use.*

2. Referenced Documents

2.1 ASTM Standards:

D 2240 Test Method for Rubber Property—Durometer Hardness²

E 11 Specification for Wire-Cloth Sieves for Testing Purposes³

E 122 Practice for Choice of Sample Size to Estimate a Measure of Quality for a Lot or Process³

E 177 Practice for Use of the Terms Precision and Bias in ASTM Test Methods³

G 40 Terminology Relating to Wear and Erosion⁴

2.2 *American Foundrymen's Society Standards:*
AFS Foundry Sand Handbook, 7th Edition⁵

3. Terminology

3.1 Definition:

3.1.1 *abrasive wear*—wear due to hard particles or hard protuberances forced against and moving along a solid surface (Terminology G 40).

NOTE 2—This definition covers several different wear modes or mechanisms that fall under the abrasive wear category. These modes may

¹ This test method is under the jurisdiction of ASTM Committee G02 on Wear and Erosion and is the direct responsibility of Subcommittee G02.30 on Abrasive Wear.

Current edition approved Oct. 10, 2000. Published November 2000. Originally published as G 65 – 80. Last previous edition G 65 – 94 (2000)^{e1}.

² *Annual Book of ASTM Standards*, Vol 09.01.

³ *Annual Book of ASTM Standards*, Vol 14.02.

⁴ *Annual Book of ASTM Standards*, Vol 03.02.

⁵ Available from American Foundrymen's Society, Golf and Wolf Roads, Des Plaines, IL 60016.

degrade a surface by scratching, cutting, deformation, or gouging (1 and 6).⁶

4. Summary of Test Method

4.1 The dry sand/rubber wheel abrasion test (Fig. 1) involves the abrading of a standard test specimen with a grit of controlled size and composition. The abrasive is introduced between the test specimen and a rotating wheel with a chlorobutyl rubber tire or rim of a specified hardness. This test specimen is pressed against the rotating wheel at a specified force by means of a lever arm while a controlled flow of grit abrades the test surface. The rotation of the wheel is such that its contact face moves in the direction of the sand flow. Note that the pivot axis of the lever arm lies within a plane which is approximately tangent to the rubber wheel surface, and normal to the horizontal diameter along which the load is applied. The test duration and force applied by the lever arm is varied as noted in Procedure A through E. Specimens are weighed before and after the test and the loss in mass recorded. It is necessary to convert the mass loss to volume loss in cubic millimetres, due to the wide differences in the density of materials. Abrasion is reported as volume loss per specified procedure.

5. Significance and Use (1-7)

5.1 The severity of abrasive wear in any system will depend upon the abrasive particle size, shape, and hardness, the magnitude of the stress imposed by the particle, and the frequency of contact of the abrasive particle. In this practice these conditions are standardized to develop a uniform condition of wear which has been referred to as scratching abrasion (1 and 2). The value of the practice lies in predicting the relative ranking of various materials of construction in an abrasive environment. Since the practice does not attempt to

duplicate all of the process conditions (abrasive size, shape, pressure, impact, or corrosive elements), it should not be used to predict the exact resistance of a given material in a specific environment. Its value lies in predicting the ranking of materials in a similar relative order of merit as would occur in an abrasive environment. Volume loss data obtained from test materials whose lives are unknown in a specific abrasive environment may, however, be compared with test data obtained from a material whose life is known in the same environment. The comparison will provide a general indication of the worth of the unknown materials if abrasion is the predominant factor causing deterioration of the materials.

6. Apparatus and Material⁷

6.1 Fig. 2 shows a typical design and Fig. 3 and Fig. 4 are photographs of the test apparatus which may be constructed from readily available materials. Also, see Ref (2). Several elements are of critical importance to ensure uniformity in test results among laboratories. These are the type of rubber used on the wheel, the type of abrasive and the shape, positioning and the size opening of the sand nozzle, and a suitable lever arm system to apply the required force.

6.2 *Rubber Wheel*—The wheel shown in Fig. 5 shall consist of a steel disk with an outer layer of chlorobutyl rubber molded to its periphery. Uncured rubber shall be bonded to the rim and fully cured in a steel mold. The optimum hardness of the cured rubber is Durometer A-60. A range from A58 to 62 is acceptable. At least four hardness readings shall be taken on the rubber approximately 90° apart around the periphery of the wheel using a Shore A Durometer tester in accordance with Test Method D 2240. The gage readings shall be taken after a dwell time of 5 s. The recommended composition of the rubber and a qualified molding source is noted in Table 1. (See 9.9 for preparation and care of the rubber wheel before and after use and see Fig. 2 and Fig. 5.)

6.3 *Abrasive*—The type of abrasive shall be a rounded quartz grain sand as typified by AFS 50/70 Test Sand (Fig. 6).⁸ The moisture content shall not exceed 0.5 weight %. Sand that has been subjected to dampness or to continued high relative humidity may take on moisture, which will affect test results. Moisture content may be determined by measuring the weight loss after heating a sample to approximately 120°C (250°F) for 1 h minimum. If test sand contains moisture in excess of 0.5 % it shall be dried by heating to 100°C (212°F) for 1 h minimum and the moisture test repeated. In high-humidity areas sand may be effectively stored in constant temperature and humidity rooms or in an enclosed steel storage bin equipped with a 100-W electric bulb. Welding electrode drying ovens, available from welding equipment suppliers are also suitable. Multiple use of the sand may affect test results and is not recommended. AFS 50–70 Test Sand is controlled to the following size range using U.S. sieves (Specification E 11).

⁶ The boldface numbers in parentheses refer to the list of references at the end of this test method.

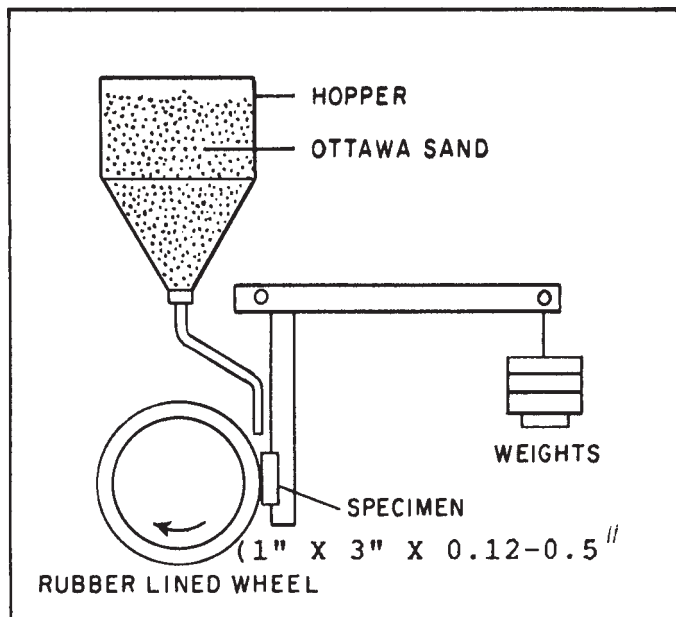

FIG. 1 Schematic Diagram of Test Apparatus

⁷ Original users of this test method fabricated their own apparatus. Machines are available commercially from several manufacturers of abrasion testing equipment.
⁸ Available from U.S. Silica Co., P.O. Box 577, Ottawa, IL 61350. Sand from other sources was not used in the development of this test method and may give different results.

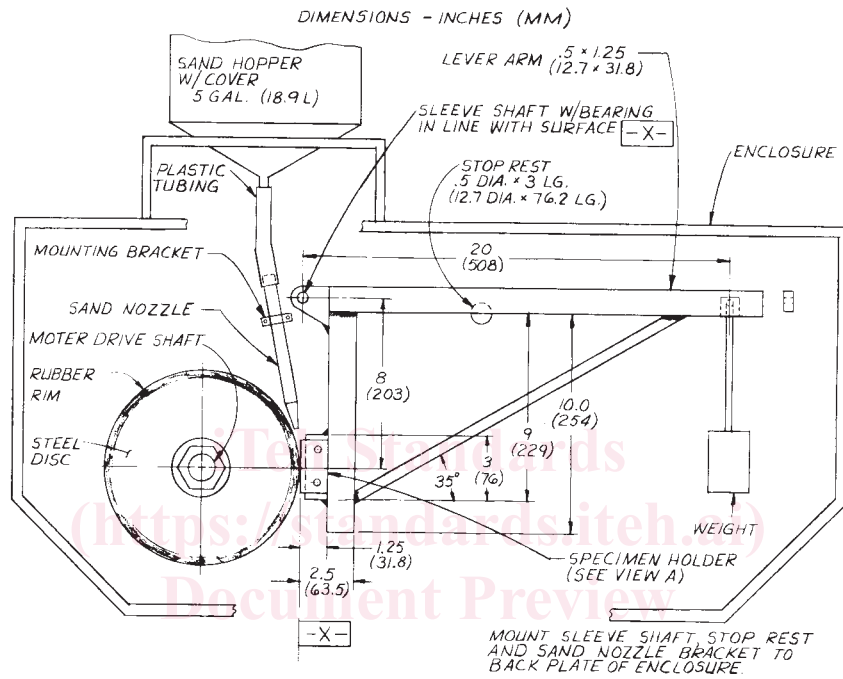
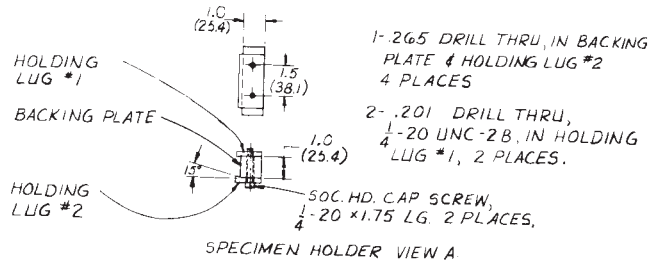

FIG. 2 Dry Sand/Rubber Wheel Abrasion Test Apparatus

<https://standards.iteh.ai/catalog/standards/sist/60427cc7-1add-4bd5-b812-7b8027c250bd/astm-g65-00>

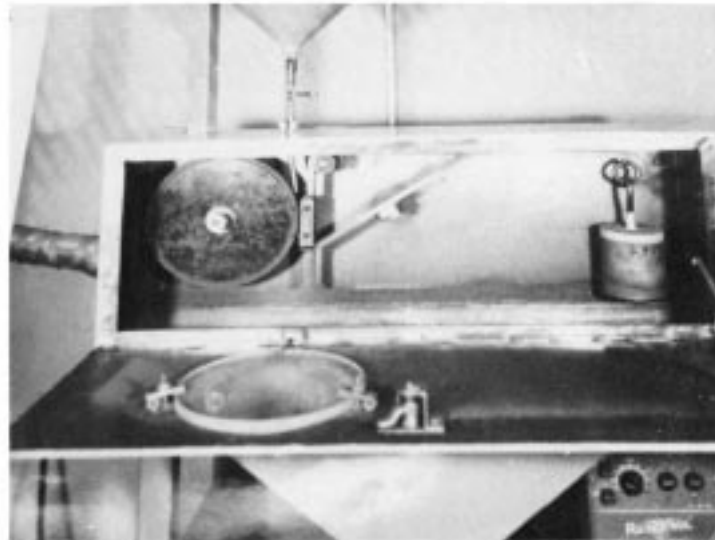

FIG. 3 Wheel and Lever Arm

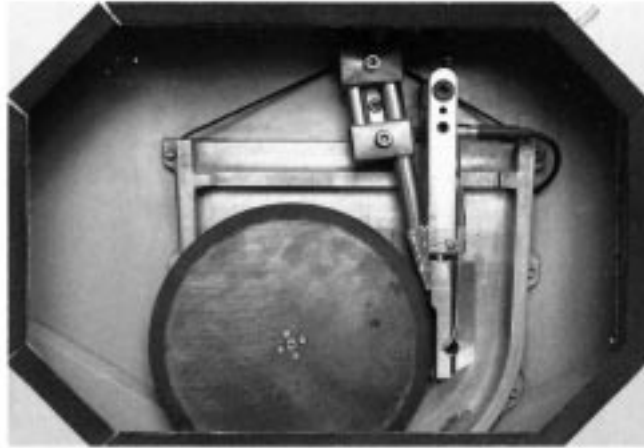

FIG. 4 Enclosure Frame

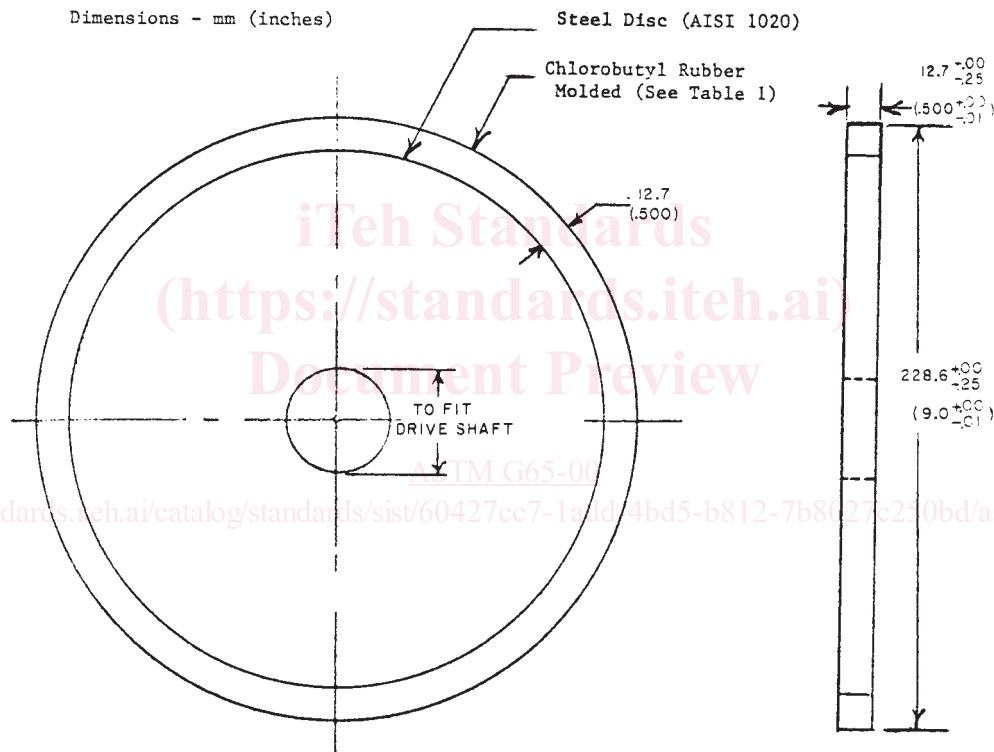

FIG. 5 Rubber Wheel

U.S. Sieve Size	Sieve Opening	% Retained on Sieve
40	425 μm (0.0165 in.)	none
50	300 μm (0.0117 in.)	5 max
70	212 μm (0.0083 in.)	95 min
100	150 μm (0.0059 in.)	none passing

6.4 Sand Nozzle—Fig. 7 shows the fabricated nozzle design which was developed to produce an accurate sand flow rate and proper shape of sand curtain for test procedures. The nozzle may be of any convenient length that will allow for connection to the sand hopper using plastic tubing. In new nozzles, the rate of sand flow is adjusted by grinding the orifice of the nozzle to increase the width of the opening to develop a sand flow rate of 300 to 400 g/min. During use, the nozzle opening must be positioned as close to the junction of the test specimen and the rubber wheel as the design will allow. (See Fig. 8.)

6.4.1 Any convenient material of construction that is available as welded or seamless pipe may be used for the construction of the fabricated nozzle. Stainless steel is preferred because of its corrosion resistance and ease of welding. Copper and steel are also used successfully.

6.4.2 Formed Nozzle—Nozzles formed from tubing may be used only when they duplicate the size and shape (rectangular orifice and taper), and the sand flow characteristics (flow rate and streamlined flow) of the fabricated nozzle. (See Fig. 7 and Fig. 9.)

6.4.3 Sand Flow—The nozzle must produce a sand flow rate of 300 to 400 g/min (0.66 to 0.88 lb/min).

6.4.4 Sand Curtain—Fig. 9 shows the proper stream-lined flow and the narrow shape of the sand curtain as it exits from

TABLE 1 Formula for Chlorobutyl Rubber^A

NOTE 1—Specific gravity of mix: 1.15. Pressure cure: 20 min at 160°C (320°F).

Materials	Proportions by Weight
Chlorobutyl No. HT 10-66 (Enjay Chemical)	100
Agerite Staylite-S	1
HAF black	60
Circolight oil	5
Stearic acid	1
Zinc oxide	5
Ledate	2

^A The sole source of supply known to the committee at this time is Action Rubber Co., Inc., 601 Fame Rd., Dayton, OH 45449. If you are aware of alternative suppliers, please provide this information to ASTM Headquarters. Your comments will receive careful consideration at a meeting of the responsible technical committee, which you may attend.

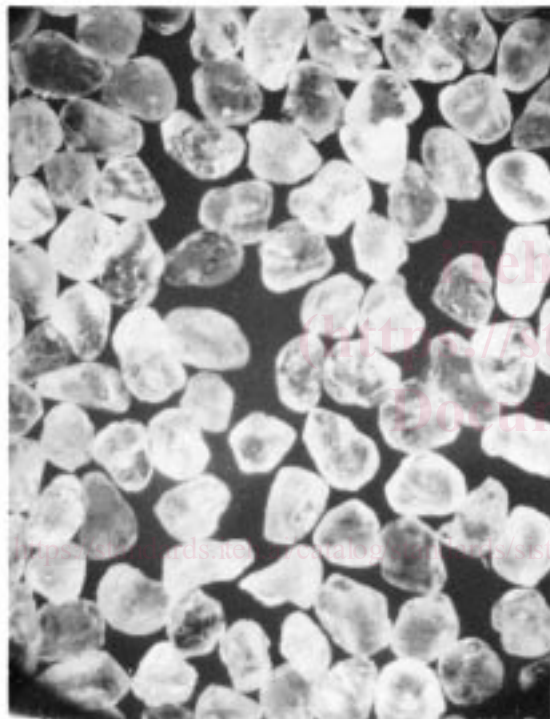

FIG. 6 25X Magnification AFS 50/70 Test Sand Ottawa Silica Co.

the sand nozzle. A turbulent sand flow as depicted in Fig. 10 will tend to produce low and inconsistent test results. It is intended that the sand flows in a streamlined manner and passes between the specimen and rubber wheel.

6.5 Motor Drive—The wheel is driven by a nominally 0.7-kW (1-hp) d-c motor through a 10/1 gear box to ensure that full torque is delivered during the test. The rate of revolution (200 ± 10 rpm) must remain constant under load. Other drives producing 200 rpm under load are suitable.

6.6 Wheel Revolution Counter—The machine shall be equipped with a revolution counter that will monitor the number of wheel revolutions as specified in the procedure (Section 9). It is recommended that the incremental counter have the ability to shut off the machine after a preselected number of wheel revolutions or increments up to 12 000 revolutions is attained.

6.7 Specimen Holder and Lever Arm—The specimen holder is attached to the lever arm to which weights are added, so that a force is applied along the horizontal diametral line of the wheel. An appropriate number of weights must be available to apply the appropriate force (Table 2) between the test specimen and the wheel. The actual weight required should not be calculated, but rather should be determined by direct measurement by noting the load required to pull the specimen holder away from the wheel. A convenient weight system is a can filled with sand (see Fig. 2).

6.8 Analytical Balance—The balance used to measure the loss in mass of the test specimen shall have a sensitivity of 0.001 g. Procedure C requires a sensitivity of 0.0001 g.

6.9 Enclosure, Frame, and Abrasive Hopper—Fig. 3 and Fig. 4 are photographs of a typical test apparatus. The size and shape of the support elements, enclosure, and hopper may be varied according to the user’s needs.

7. Specimen Preparation and Sampling

7.1 Materials—It is the intent of this test method to allow for the abrasion testing of any material form, including wrought metals, castings, forgings, gas or electric weld overlays, plasma spray deposits, powder metals, metallizing, electroplates, cermets, ceramics etc. The type of material will, to some extent, determine the overall size of the test specimen.

7.2 Typical Specimen, a rectangular shape 25 by 76 mm (1.0 by 3.0 in.) and between 3.2 and 12.7 mm (0.12 and 0.50 in.) thick. The size may be varied according to the user’s need with the restriction that the length and width be sufficient to show the full length of the wear scar as developed by the test. The test surface should be flat within 0.125 mm (0.005 in.) maximum.

7.3 Wrought, Cast, and Forged Metal—Specimens may be machined to size directly from the raw material.

7.4 Electric or Gas Weld Deposits are applied to one flat surface of the test piece. Double-weld passes are recommended to prevent weld dilution by the base metal. The heat of welding may distort the test specimen. When this occurs, the specimen may be mechanically straightened or ground, or both. In order to develop a suitable wear scar, the surface to be abraded must be ground flat to produce a smooth, level surface at least 63.4 mm (2.50 in.) long and 19.1 mm (0.75 in.) for the test. (See 7.5.) Note that the welder technique, heat input of welds, and the flame adjustment of gas welds will have an effect on the abrasion resistance of a weld deposit.

7.5 Finish—Test specimens should be smooth, flat, and free of scale. Surface defects such as porosity and roughness may bias the test results, and such specimens should be avoided unless the surface itself is under investigation. Typical suitable surfaces are mill-rolled surfaces such as are present on cold-rolled steel, electroplated and similar deposits, ground surfaces, and finely machined or milled surfaces. A ground surface finish of approximately 0.8 μm (32 μin.) or less is acceptable. The type of surface or surface preparation shall be stated in the data sheet.

FABRICATED SAND NOZZLE

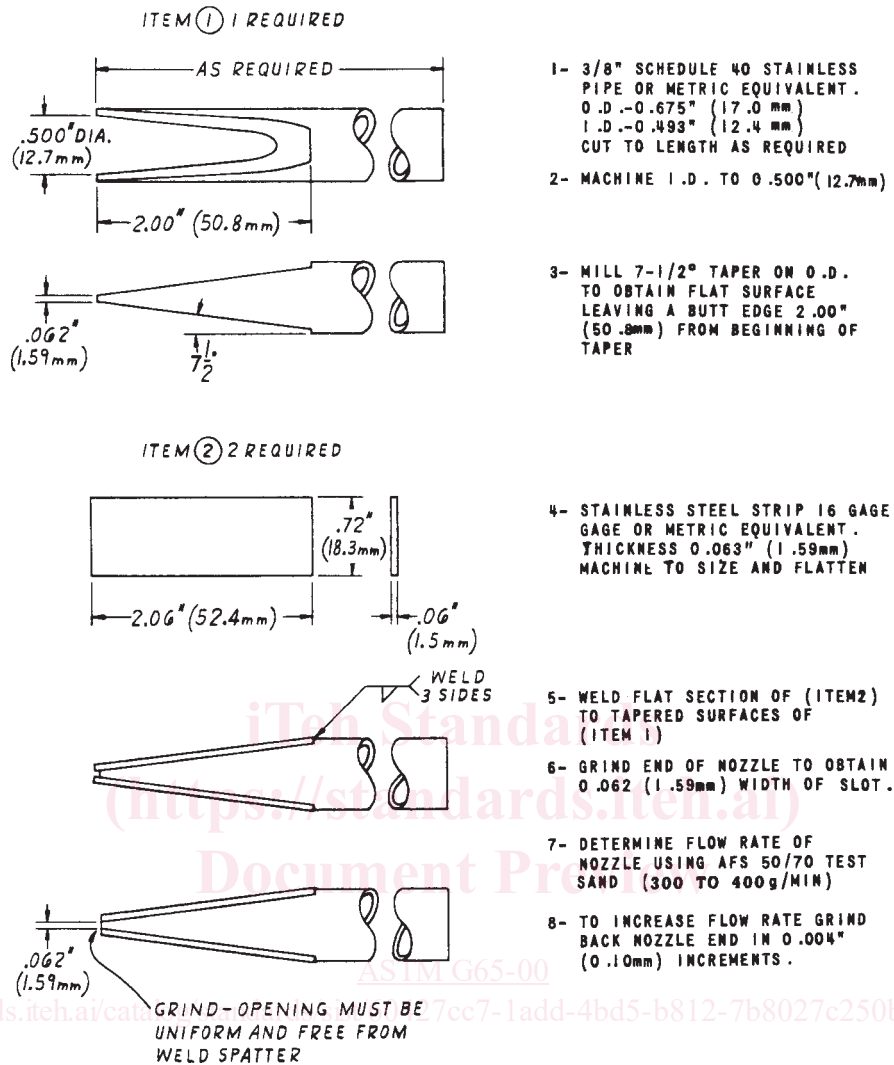

FIG. 7 Sand Nozzle

8. Test Parameters

8.1 Table 2 indicates the force applied against the test specimen and the number of wheel revolutions for test Procedures A through E.

8.2 Sand Flow—The rate of sand flow shall be 300 to 400 g/min (0.66 to 0.88 lb/min).

8.3 Time—The time of the test will be about 30 min for Procedures A and D, 10 min for Procedure B, 5 min for Procedure E, and 30 s for Procedure C, depending upon the actual wheel speed. In all cases the number of wheel revolutions and not the time shall be the controlling parameter.

8.4 Lineal Abrasion—Table 2 shows the lineal distance of scratching abrasion developed using a 228.6-mm (9-in.) diameter wheel rotating for the specified number of revolutions. As the rubber wheel reduces in diameter the number of wheel revolutions shall be adjusted to equal the sliding distance of a new wheel (Table 2) or the reduced abrasion rate shall be taken into account by adjusting the volume loss produced by the worn wheel to the normalized volume loss of a new wheel. (See 10.2.)

9. Procedure

9.1 Cleaning—Immediately prior to weighing, clean the specimen with a solvent or cleaner and dry. Take care to remove all dirt or foreign matter or both from the specimen. Dry materials with open grains (some powder metals or ceramics) to remove all traces of the cleaning solvent, which may have been entrapped in the material. Steel specimens having residual magnetism should be demagnetized or not used.

9.2 Weigh the specimen to the nearest 0.001 g (0.0001 g for Procedure C).

9.3 Seat the specimen securely in the holder and add the proper weights to the lever arm to develop the proper force pressing the specimen against the wheel. This may be measured accurately by means of a spring scale which is hooked around the specimen and pulled back to lift the specimen away from the wheel. A wedge should be placed under the lever arm so that the specimen is held away from the wheel prior to start of test. (See Fig. 2.)