



Standard Test Method for Pin Abrasion Testing¹

This standard is issued under the fixed designation G 132; the number immediately following the designation indicates the year of original adoption or, in the case of revision, the year of last revision. A number in parentheses indicates the year of last reapproval. A superscript epsilon (ϵ) indicates an editorial change since the last revision or reapproval.

1. Scope

1.1 This test method covers a laboratory procedure for determining the wear resistance of a material when relative motion is caused between an abrasive cloth, paper, or plastic film and a contacting pin of the test material. The principal factors and conditions requiring attention when using this type of apparatus to measure wear are discussed.

1.2 The values stated in SI units are to be regarded as the standard. The values given in parentheses are for information only.

1.3 *This standard does not purport to address all of the safety concerns, if any, associated with its use. It is the responsibility of the user of this standard to establish appropriate safety and health practices and determine the applicability of regulatory limitations prior to use.*

2. Referenced Documents

2.1 ASTM Standards:

A 128/A128M Specification for Steel Castings, Austenitic Manganese²

A 514/A514M Specification for High-Yield Strength, Quenched and Tempered Alloy Steel Plate, Suitable for Welding³

E 122 Practice for Choice of Sample Size to Estimate the Average Quality of a Lot or Process⁴

E 177 Practice for Use of the Terms Precision and Bias in ASTM Test Methods⁴

E 691 Practice for Conducting an Interlaboratory Study to Determine the Precision of a Test Method⁴

G 40 Terminology Relating to Wear and Erosion⁵

3. Terminology

3.1 Refer to Terminology G 40 for definitions of terms related to this test method.

¹ This test method is under the jurisdiction of ASTM Committee G-2 on Wear and Erosion and is the direct responsibility of Subcommittee G02.30 on Abrasive Wear.

Current edition approved Nov. 10, 1996. Published January 1997. Originally published as G 132 – 95. Last previous edition G 132 – 95.

² *Annual Book of ASTM Standards*, Vol 01.02.

³ *Annual Book of ASTM Standards*, Vol 01.04.

⁴ *Annual Book of ASTM Standards*, Vol 14.02.

⁵ *Annual Book of ASTM Standards*, Vol 03.02.

4. Summary of Test Method

4.1 For the pin abrasion test method, two pin specimens are required. One is of the test material. The other is of a reference material. Each pin, in turn, is positioned perpendicular to the abrasive surface, which usually is mounted on, or supported by, a flat circular disk, another flat surface, or the cylindrical surface of a drum. The test machine permits relative motion between the abrasive surface and the pin surface. The wear track of a pin describes a continuous, non-overlapping path such as a spiral, helix, or saw-tooth curve, preferably with a displacement between successive passes sufficient to allow the other pin to trace a parallel track in the intervening space. Fig. 1 shows some possible arrangements. The pin specimen is pressed against the abrasive surface with a specified loading by means of dead weights or another suitable loading system. Rotation of the pin about its axis during testing is optional. Note, however, that results with and without pin rotation or with different loading systems may differ.

4.2 The amount of wear is determined by weighing both specimens before and after testing. Mass loss values should be converted to volume losses using the best available values of specimen densities. The use of length changes to indicate the amount of wear is not recommended for the purposes of this test method, and no procedure for processing such data is included in this test method.

4.3 Wear results are reported as a volume loss and as the wear volume normalized with respect to the applied normal load, to the wear path length, and to the mean wear of the reference specimen on the same type of abrasive. The reference specimen wear is included in the calculation in order to correct for abrasivity variations (see 4.5 and 10.2).

4.4 Various sizes and types of abrasive have been used. These include silicon carbide, alumina, emery, garnet, flint, or other silicas, and synthetic compounds, but wear results normally will differ with different types of abrasive (see Table X3.1). The abrasive is bonded to a cloth, paper, or plastic film (usually polyester) backing that is mounted on or supported by a smooth, firm surface (for example, disk, other flat, or cylinder). For purposes of this test method, a garnet is the preferred abrasive and has given good correlations with many types of abrasive services (1).⁶ The field experience has included a wide variety of abrasive minerals, ranging from

⁶ The boldface numbers in parentheses refer to the list of references at the end of this test method.

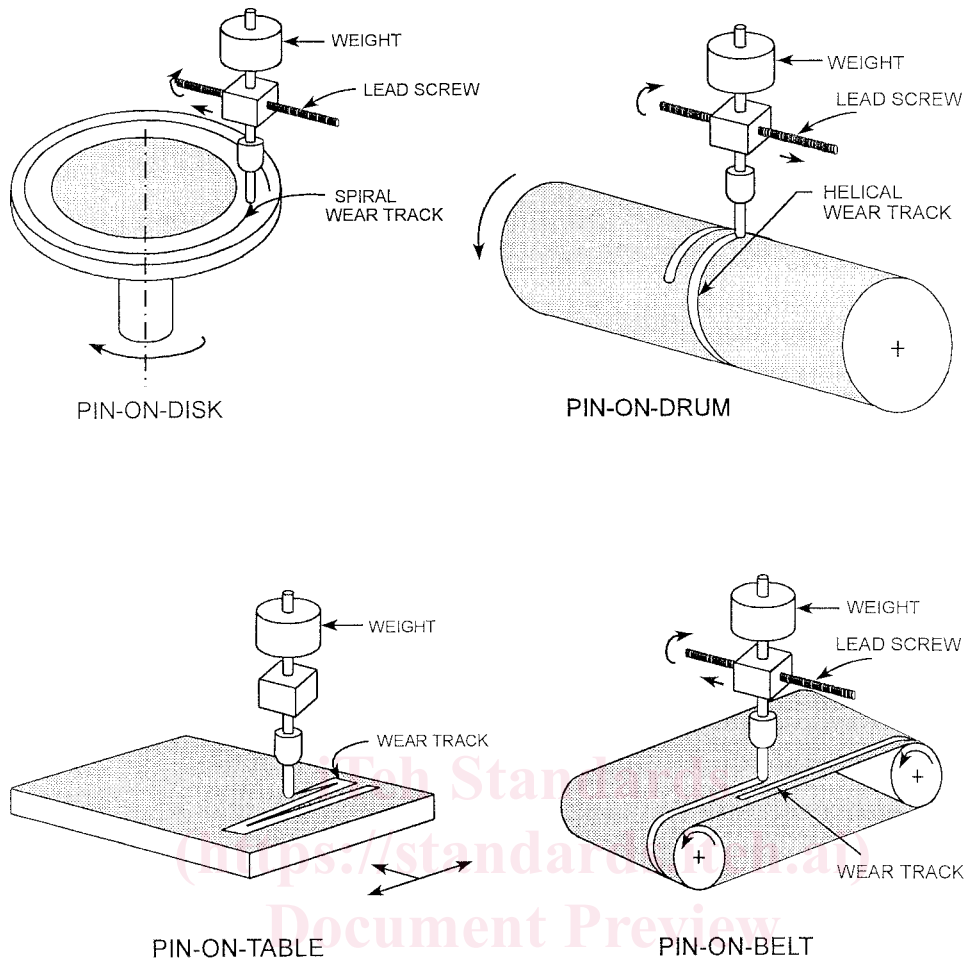

FIG. 1 Four Configurations of Pin Abrasion Testing Machines

coarse rock to fine ore, rounded or crushed, with high or light loading.

4.5 In this test method, the primary role of the reference material is to correct for variations in the abrasivity of the abrasive cloth or paper. Because of abrasivity variability, the reference material wear in a particular test may deviate from the overall mean for tests using the same abrasive. The reference material's function here differs from that in other tests where a direct comparison between the test material and reference material is used as a basis for ranking the abrasion resistances of materials or where the wear of a reference material is used as the basis for ranking the abrasivities of abrasive materials.

5. Significance and Use

5.1 The amount of wear in any system will, in general, depend upon a number of system factors such as the applied load, machine characteristics, sliding speed, sliding distance, the environment, and material properties. The primary value of this wear test method lies in predicting the relative ranking of materials. This test method imposes conditions that cause measurable mass losses and it is intended to rank materials for applications in which moderate to severe abrasion occurs. Test materials should be reasonably resistant to such abrasion. Since this abrasion test does not attempt to duplicate all of the

conditions that may be experienced in service (for example, abrasive particle size, shape, hardness, speed, load, and presence of a corrosive environment), there is no assurance that this test method will predict the wear rate of a given material under conditions differing from those in this test method.

6. Apparatus

6.1 *General Description*—Refer to Fig. 1 where schematic drawings of typical pin-on-disk, pin-on-table, pin-on-belt, and pin-on-drum wear testing systems are shown.⁷ In each of the systems, the end of a pin, which may or may not be rotating about its axis, is pressed against an abrasive surface with application of a prescribed normal force while relative motion occurs between the pin and the abrasive surface. By moving either the abrasive surface or the pin, or both, the pin progressively moves over unused abrasive for a prescribed wear track length.

⁷ Other descriptions of contemporary pin-on-disk, pin-on-table, and pin-on-drum systems may be found in Practice F 732, Test Method G 99, and Ref (2). An acceptable pin-on-disk machine is available from Falex Corp., 1020 Airpark Dr., Sugar Grove, IL 60554. Many lathes should be adaptable for pin-on-drum testing. Falex Corp. is the sole source of supply of the pin-on-disk machine known to the committee at this time. If you are aware of alternative suppliers, please provide this information to ASTM Headquarters. Your comments will receive careful consideration at a meeting of the responsible technical committee,¹ which you may attend.

6.1.1 The wear path is normally a spiral on disks, a combination of linear segments on other flats, an oval helix on belts, and a cylindrical helix on drums. Successive wear track passes of the test pin should be spaced far enough apart so that the reference pin can be tested on unused abrasive in a path adjacent and parallel to that of the test pin. If, as in some machines, insufficient unused abrasive space is left between the tracks, the wear track of the reference pin should be generated in two equal parts located immediately before and after the test pin track (see 9.10).

6.2 *Machine Rigidity*—The testing machine must be sufficiently rigid and stable to keep vibrations from affecting wear test results. The load capacities of bearings should be large relative to the loads carried. The surface that supports the abrasive should be rigid. Additional guidance concerning rigidity requirements for wear testing may be found in Ref (3).

6.3 *Drive System*—A drive system capable of maintaining a constant steady-state speed of the abrasive relative to the pin is needed. For the pin-on-disk machine, the rotational speed must vary inversely with the radial distance of the pin from the disk's center in order for the linear speed to be constant. For the pin-on-table machine, there inevitably must be a point of rest and transient deceleration and acceleration periods at each end of each stroke, and the translational speed can be constant only between the acceleration and deceleration periods. The transient periods should be kept as short as possible. If the pin is rotated, its rotational speed should be constant.

6.4 *Cycle Counter*—The test machine shall be equipped with a device that will count and record the number of revolutions in the case of a disk, drum, or belt, or the number of strokes or cycles in the case of a nonrotating flat. This device should also have the capability to shut off the machine after a preselected number of revolutions, strokes, or cycles.

6.5 *Pin Specimen Holder*—A chuck, collet, or other device is required to securely hold the pin. The holder must move freely, with negligible friction, in the direction of its longitudinal axis (that is, perpendicular to the abrasive surface), even if rotated. The pin must be restrained from lateral deflection due to pin drag. A means of applying a load to the pin, preferably by dead weights, shall be provided.

6.6 *Wear Measuring System*—The balance used to measure the mass loss of specimens shall have a sensitivity of 0.0001 g or better.

7. Test Specimens, Abrasive, and Sample Preparation

7.1 *Materials*—The test method may be applied to a variety of wear-resistant materials. The only requirement is that specimens having suitable dimensions can be prepared and that they will withstand the stresses imposed during the test without failure or excessive flexure. This test method is not intended for a material that would be unsuitable for a wear-resistant application.

7.1.1 Experience during the development of this test method has shown that the use of Specification A 514/A 514M, Type B steel of Hardness 269 HB, as the reference material has very adequately corrected for abrasivity variations. It is therefore specifically recommended for that purpose. If another reference material is used, it must be fully described and characterized in the report of results.

7.2 *Test Specimens*—Pin specimens used with a pin-on-drum machine during the development of this test method were circular cylinders, 6.35 mm in diameter and approximately 3 cm long. More generally, typical pin diameters range from 2 to 10 mm. Specimens of square cross section also have been used. Pin ends are conformed to the abrasive surface by wearing in as part of the test procedure (see 9.3), so the starting shape is not critical. However, flat ends are most common and, in most cases, require shorter times and path lengths for wearing in.

7.2.1 Test specimens shall be free from scale which could flake off and interfere with the specimen-abrasive contact. Porosity, unless it is an inherent characteristic of the material being tested, may adversely affect test results and should be avoided. The shank of a specimen that must be gripped should be smooth and regularly shaped. A ground surface roughness of 1 μm (40 $\mu\text{in.}$) R_a or less is usually adequate.

7.3 *Abrasive*—The abrasive recommended is a 105- μm (150-grit) garnet, bonded to cloth, paper, or plastic (for example, polyester film) with animal glue or synthetic resin, or both. The abrasive coverage is 50 to 70 % of the surface area, uniformly distributed. Normally, the abrasive cloth, paper, or film is obtained from a commercial producer.⁸ If other particle sizes of the same or another mineral are used, they should be in the range from 65 to 175 μm (220 to 80 grit).

7.4 *Abrasivity*—The abrasivity of a particular abrasive cloth, paper, or film normally is not uniform over its surface nor is the mean abrasivity of different pieces of the same type of material necessarily the same. Variations in abrasivity range up to ± 20 % from the overall mean. Corrections for abrasivity variations are made by normalizing the results of individual tests to the mean wear of the reference material over many tests (see 10.2).

8. Test Parameters

8.1 *Load*—The magnitude of the normal force, in newtons, at the wearing contact. Based on the nominal contact area of the specimen, the nominal contact pressure should be within the range from 1 to 2.5 MPa. It has been shown (1) that, within this range, the wear is essentially proportional to the loading. A nominal contact pressure of about 2 MPa allows minimal use of abrasive by limiting the requisite path length without a high risk of tearing the backing material.

8.2 *Translational Speed*—The mean relative sliding speed (track length/sliding time) between the contacting surfaces. It should be within the range from 1 to 10 cm/s.

8.3 *Rotational Speed*—The rate at which pins are rotated. Unless it was zero it has been typically in the range from 1.57 to 5.24 rad/s (15 to 50 r/min).

8.4 *Track Length*—The distance slid, in metres.

8.5 *Environment*—Room air at a nominal temperature of 20 to 25°C. The relative humidity and any uncommon environmental exposure should be reported.

⁸ Acceptable cloths, papers, and films coated with garnet or other minerals may be obtained from authorized distributors of the 3M Co. Inquiries may be directed to the General Offices, 3M Center, St. Paul, MN 55102. 3M Company is the sole source of supply of the materials known to the committee at this time. If you are aware of alternative suppliers, please provide this information to ASTM Headquarters. Your comments will receive careful consideration at a meeting of the responsible technical committee,¹ which you may attend.

8.6 Table 1 gives some typical values of test parameters.

9. Procedure

9.1 Immediately prior to testing, and prior to weighing, thoroughly clean and dry the specimens. Care must be taken to remove all dirt and foreign matter from the specimens. Use non-chlorinated, non-film-forming, noncorrosive cleaning agents and solvents. Extra effort may be needed with open-grained materials to ensure removal of all traces of fluids which may be entrapped in the material. Demagnetize ferromagnetic materials having residual magnetism. Report the methods used for cleaning.

9.2 Mount a sheet, disk, sleeve, or belt of the selected abrasive cloth, paper, or film to or over the appropriate supporting surface in the test machine. If a sheet is wrapped on a drum and edges must be joined, be sure that the edges are cut cleanly and be careful to avoid any gaps, ridges, or other unevenness at the join.

9.3 The ends of the pins should be worn in by performing 9.6-9.9 to remove enough material to conform the contacting surfaces. The length of pin removed by abrasion also should equal or exceed the dimension of the largest microstructural feature of the pin material. A 4 to 10-m track length is adequate for most steels unless the pin end is unusually irregular. However, most of the wearing in can be done on previously used abrasive, finishing up on fresh abrasive.

9.4 If necessary, mount fresh abrasive material in the test machine.

9.5 Weigh the pins to the nearest 0.0001 g (0.1 mg).

9.6 Insert a pin specimen securely in the holder. Do not allow the pin to protrude more than 4 mm. If the pin was not rotated as it was worn in, it must be carefully repositioned in the same orientation on any curved surface.

9.7 Apply the prescribed force on the pin perpendicular to the abrasive surface.

9.8 Set the cycle counter to the appropriate number of revolutions or strokes to achieve the desired track length.

9.9 Begin the test with the specimen in contact under load. Stop the test when the desired track length has been achieved.

9.10 Repeat the test with the other pin. The sequence of testing the test pin and reference pin depends upon the wear track configuration. If the wear track on the abrasive surface leaves an unworn space, as the preferred configuration would, either the test pin or the reference pin may be tested first and the other pin will then be tested for the same distance on the intervening unworn abrasive. If insufficient unworn space is left, the reference pin should be tested last for the same total distance on a divided track, half ahead of and half following the test pin track.

9.11 Using precautions such as those in 9.1, clean the specimens to remove any extraneous material and reweigh them to obtain their masses to the same tolerance level as the initial values. Report the cleaning procedure.

TABLE 1 Typical Test Parameters Used By Three Laboratories With Various Abrasives

Pin Diameter, mm	Force, N	Speed, m/s	Pin Rotation, r/min	Path Length, m
6.35	66.7	0.04	17 to 20	4 to 16

9.12 Repeat the test as required to obtain results with an acceptable degree of statistical significance. (See Practice E 691.)

10. Calculation and Reporting

10.1 The report must contain all information necessary to permit independent repetition of the test method. This shall include the shape and dimensions of specimens, the material type, composition, processing or preparation history, microstructure and indentation hardness, if appropriate, and any other characterizing details that may apply in special cases. The abrasive shall be adequately described. The type, grit or particle size, the backing material and bonding materials used, the manufacturer, source, and lot number should be given. Test conditions to be reported include the type of testing machine used, the load applied, the linear speed of specimens across the abrasive surface, and the track length. The ambient temperature and relative humidity should also be reported.

10.2 The volume losses (that is, mass losses divided by density) of individual specimens shall be reported in cubic millimetres. In addition, to account for abrasivity variations, report wear measurements as a normalized volume loss per unit track length per unit load, in cubic millimetres per newton/metre.

10.2.1 Use the following equation for calculating the normalized wear:

$$\text{wear} = \frac{C W_x}{\rho S_x} \text{mm}^3/\text{Nm} \tag{1}$$

where:

- W_x = mass loss of the test specimen, any units,
- S_x = mass loss of the reference specimen, same units,
- ρ = density of the test specimen, known or measured to three significant figures, g/cm³ (mg/mm³),
- C = reference constant equal to the mean mass loss (mg) of the reference pin per unit track length (m) per unit load (N), for the abrasive type and test parameters used. (The ratio $C:S_x$ functions as a normalizing factor.)

10.2.2 The value of the constant C for a given reference material and abrasive is determined from a large number of tests, preferably in several test machines at various locations. Several preliminary values of C , determined in a single laboratory, are given in Table 2. These were determined for a Specification A 514/A 514M steel in a pin-on-drum machine,

TABLE 2 Preliminary Values of C Determined in a Single Laboratory [Rotating Pin of Specification A 514/A 514M Steel, Type B, 269 HB Hardness]

Type	Abrasive		C ^A , mg/Nm
	Size		
	Grit	µm	
garnet	220	65	0.131
garnet	150	105	0.151
garnet	120	125	0.153
garnet	60	250	0.214
SiC	150	105	0.159
SiC	120	125	0.169
Al ₂ O ₃	150	125	0.180

^A Any one value of C , corresponding to a particular set of conditions can be used to test a wide variety of materials.