



**SLOVENSKI STANDARD**  
**SIST EN 178:1998**  
**01-november-1998**

---

Glavni predmet: Keramične ploščice in plošče, izdelane iz pražene keramike, s vodoabsorpcijo 6% ≤ E ≤ 10% (skupina BIIb)

Dust-pressed ceramic tiles with a water absorption of 6% ≤ E ≤ 10% (Group BIIb)

Trockengepreßte keramische Fliesen und Platten mit einer Wasseraufnahme von 6% ≤ E ≤ 10% (Gruppe BIIb)

Carreaux et dalles céramiques pressés à sec, à absorption d'eau 6% ≤ E ≤ 10% (Groupe BIIb)

**STANDARD PREVIEW**  
**(standards.iteh.ai)**

Ta slovenski standard je istoveten z: **EN 178:1991**  
<https://standards.iteh.ai/catalog/standards/sist/07d59cef-3072-47e8-9dcf-b7ea5703b22b/sist-en-178-1998>

---

**ICS:**

91.100.23      Sestavljeni izdelki iz keramike      Ceramic tiles

**SIST EN 178:1998**      en

**iTeh STANDARD PREVIEW**  
**(standards.iteh.ai)**

SIST EN 178:1998

<https://standards.iteh.ai/catalog/standards/sist/07d39cef-3072-47e8-9dcf-b7ea5703b22b/sist-en-178-1998>



REPUBLIKA SLOVENIJA  
 MINISTRSTVO ZA ZNANOST IN TEHNOLOGIJO  
 Urad RS za standardizacijo in meroslovje  
 LJUBLJANA

EUROPEAN STANDARD

EN 178:1991

NORME EUROPEENNE

SIST... EN 178 .....  
 PREVZET PO METODI RAZGLASITVE

EUROPAISCHE NORM

-11- 1998

September 1991

UDC 691.43:413-033.64

Supersedes EN 178:1984

Descriptors: Tiles, coating slabs, ceramic coating, Water absorption tests, equipment specifications, shape, dimensions, dimensional tolerance, appearance, physical properties, mechanical properties, chemical properties, marking

English version

Dust-pressed ceramic tiles with a water absorption of  $6\% < E \leq 10\%$  (Group BIIb)

Carreaux et dalles céramiques pressés à sec, à absorption d'eau  $6\% < E \leq 10\%$  (Groupe BIIb)      Trockengepreßte keramische Fliesen und Platten mit einer Wasseraufnahme von  $6\% < E \leq 10\%$  (Gruppe BIIb)

## iTeh STANDARD PREVIEW

(standards.iteh.ai)

This European Standard was approved by CEN on 1991-09-18. CEN members are bound to comply with the CEN/CENELEC Internal Regulations which stipulate the conditions for giving this European Standard the status of a national standard without any alteration.

Up-to-date lists and bibliographical references concerning such national standards may be obtained on application to the Central Secretariat or to any CEN member.

This European Standard exists in three official versions (English, French, German). A version in any other language made by translation under the responsibility of a CEN member into its own language and notified to the Central Secretariat has the same status as the official versions.

CEN members are the national standards bodies of Austria, Belgium, Denmark, Finland, France, Germany, Greece, Iceland, Ireland, Italy, Luxembourg, Netherlands, Norway, Portugal, Spain, Sweden, Switzerland and United Kingdom.

CEN

European Committee for Standardization  
 Comité Européen de Normalisation  
 Europäisches Komitee für Normung

Central Secretariat: rue de Stassart 36, B-1050 Brussels

(c) CEN 1991 Copyright reserved to all CEN members

Ref. No. EN 178:1991 E

Page 2  
EN 178:1991

### Foreword

This European Standard was drawn up by the Technical Committee CEN/TC 67 'Ceramic tiles', the Secretariat of which is held by UNI.

According to the common CEN/CENELEC rules, the following countries are bound to implement this European Standard:  
Austria, Belgium, Denmark, Finland, France, Germany, Greece, Iceland, Ireland, Italy, Luxembourg, Netherlands, Norway, Portugal, Spain, Sweden, Switzerland and the United Kingdom.

## iTeh STANDARD PREVIEW (standards.iteh.ai)

SIST EN 178:1998

<https://standards.iteh.ai/catalog/standards/sist/07d39cef-3072-47e8-9dcf-b7ea5703b22b/sist-en-178-1998>



## 1 Scope and field of application

This European Standard specifies the sizes, dimensional tolerances, mechanical, physical and chemical requirements, surface quality requirements and marking of ceramic tiles.

It is applicable only to dust-pressed ceramic tiles of first quality, including tiles premounted on sheets, with a water absorption of  $6\% < E < 10\%$  according to Group BIIb of EN 87, for interior and exterior use (see clause 7 ordering) on both floors and walls.

## 2 References

- EN 87 'Ceramic floor and wall tiles – Definitions, classification, characteristics and marking'  
 EN 98 'Ceramic tiles – Determination of dimensions and surface quality'  
 EN 99 'Ceramic tiles – Determination of water absorption'  
 EN 100 'Ceramic tiles – Determination of modulus of rupture'  
 EN 101 'Ceramic tiles – Determination of scratch hardness of surface according to Mohs'  
 EN 102 'Ceramic tiles – Determination of resistance to deep abrasion – Unglazed tiles'  
 EN 103 'Ceramic tiles – Determination of linear thermal expansion'  
 EN 104 'Ceramic tiles – Determination of resistance to thermal shock'  
 EN 105 'Ceramic tiles – Determination of crazing resistance – Glazed tiles'

EN 106 'Ceramic tiles – Determination of chemical resistance – Unglazed tiles'

EN 122 'Ceramic tiles – Determination of chemical resistance – Glazed tiles'

EN 154 'Ceramic tiles – Determination of resistance to surface abrasion – Glazed tiles'

EN 155 'Ceramic tiles – Determination of moisture expansion using boiling water – Unglazed tiles'

EN 163 'Ceramic tiles – Sampling and basis for acceptance'

EN 202 'Ceramic tiles – Determination of frost resistance'

## 3 Description

The definition of dust-pressed ceramic tiles is given in EN 87. Mosaic is a tile of any geometrical shape whose surface area is equal to or less than  $90\text{ cm}^2$ .

The surface of tiles and components belonging to this group can be smooth, profiled, wavy, decorated or finished in some other way. It can be unglazed (UGL), glossy, matt or semi-matt (GL).

Although tiles have visible surface and usually a surface which is intended to be adhered and bears a back panel, they may have identical surfaces without a panel or marking.

Tiles may have spacer lugs.

## 4 Shapes and sizes

For shapes and sizes see figures 1 and 2 and tables 1 and 2.

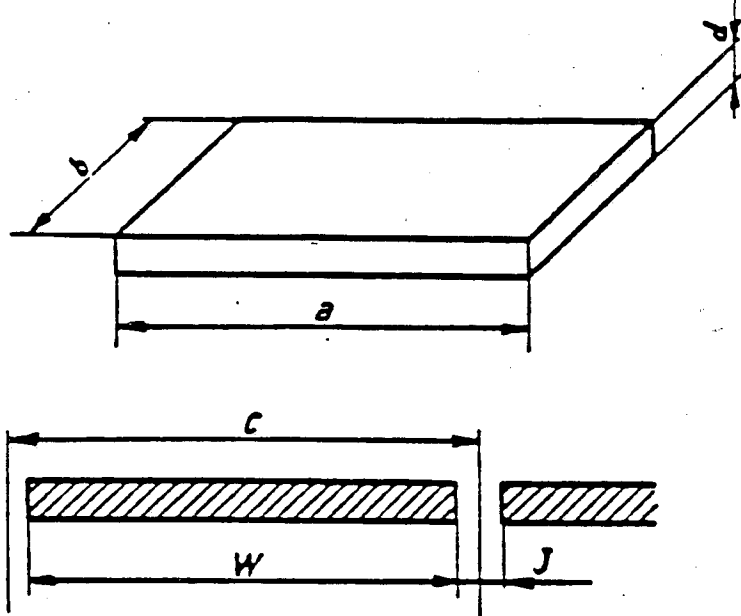

Co-ordinating size ( $C$ ) = Work size ( $W$ ) + Joint width ( $J$ )  
 Work size ( $W$ ) = Dimensions of the visible faces ( $a$ ) and ( $b$ )

Figure 1. Tile

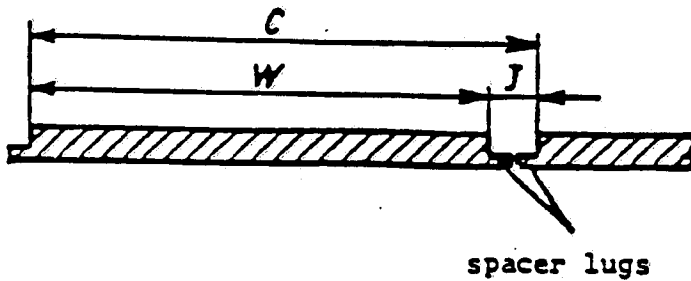

Co-ordinating size ( $C$ ) = Work size ( $W$ ) + Joint width ( $J$ )  
 Work size ( $W$ ) = Dimensions of the visible faces ( $a$ ) and ( $b$ )

Figure 2. Tile with spacer lugs

## 4.1 Modular preferred sizes

Table 1

Co-ordinating size ( $C$ ) cm	Work size ( $W$ ) mm		Thickness mm ( $d$ )
	Length ( $a$ )	Width ( $b$ )	
M 10 × 10 M 15 × 15 M 20 × 10 M 20 × 15 M 20 × 20 M 30 × 30	The manufacturer shall choose the work size in order to allow a nominal joint width of between 2 mm and 5 mm		The thickness shall be specified by the manufacturer. It includes the profile on the visible face and on the rear side

SIST EN 178:1998

## 4.2 Non-modular sizes

The most common sizes are:

<https://standards.iteh.ai/catalog/standards/sist/07d39cef-3072-47e8-9dcf-b7ea5703b22b/sist-en-178-1998>

Table 2

Nominal size ( $N$ ) cm	Work size ( $W$ ) mm		Thickness mm ( $d$ )
	Length ( $a$ )	Width ( $b$ )	
10 × 10 15 × 7,5 15 × 10 15 × 15 15,2 × 7,6 15,2 × 15,2 20 × 10 20 × 20 25 × 25 30 × 15 30 × 20 30 × 30 40 × 30	The manufacturer shall choose the work size in such a way that the difference between the work size and the nominal size is not more than ± 2 % and 5 mm		The thickness shall be specified by the manufacturer. It includes the profile on the visible face and on the rear side

#### 4.3 Other sizes

For tiles with dimensions other than those given in tables 1 and 2 the work size shall be stated by the manufacturer. The relevant requirements for work size and thickness given in the respective tables are applicable.

#### 4.4 Spacer lug tiles

Spacer lugs are projections, which are located along certain edges of tiles so that when two tiles are placed together, in line, the lugs on adjacent edges separate the tiles by a distance not less than the specified width of joint. Lugs are positioned so that the joint between the tiles may be filled with grout without the lugs remaining exposed.

Dust-pressed tiles may be made with other spacer lug systems and in such cases the manufacturer's work size shall apply.

For example of spacer lug tiles see figure 2.

NOTE. Some tiles have one or more manufacturing projections part way along certain edges and smaller than 0.3 mm. These are not intended as spacer lugs and should not be used to space joints.

#### 4.5 Accessories

Dimensions of accessories and their tolerances are not standardized and these shall be stated by the manufacturer where appropriate.

### 5 Requirements

Given the wide diversity of tile/component sizes as found in practice, shape and dimensional requirements shall be based upon the surface area determined by nominal dimensions of the tiles and components in question.

Dimensional and surface quality requirements and physical and chemical properties shall be as given in table 3.

Sampling and basis for acceptance shall be in accordance with EN 163.

Table 3

	Surface <i>S</i> of the product (cm <sup>2</sup> )				Test according to
	<i>S</i> < 90	90 < <i>S</i> < 190	190 < <i>S</i> < 410	<i>S</i> > 410	
<b>Dimensions and surface quality</b>					
<i>Length and width</i>					
e The deviation in % of the average size of each tile (2 or 4 sides) from the work size ( <i>W</i> )	± 1,2	± 1,0	± 0,75	± 0,6	EN 98
f The deviation in % of the average size of each tile (2 or 4 sides) from the average size of the 10 test specimens (20 or 40 sides)	± 0,75	± 0,5	± 0,5	± 0,5	EN 98
<i>Thickness</i>					
The deviation, in % of the average thickness of each tile from the work size thickness	± 10	± 10	± 5	± 5	EN 98
<i>Straightness of sides</i> <sup>1)</sup> (facial sides)					
The maximum deviation from straightness, in % related to the corresponding work sizes	± 0,75	± 0,5	± 0,5	± 0,5	EN 98
<i>Rectangularity</i> <sup>1)</sup>					
The maximum deviation from rectangularity in % related to the corresponding work sizes	± 1,0	± 0,6	± 0,6	± 0,6	EN 98
<i>Surface flatness</i>					
The maximum deviation from flatness, in %					
(a) Centre curvature, related to diagonal calculated from the work sizes	± 1,0	± 0,5	± 0,5	± 0,5	EN 98
(b) Edge curvature, related to the corresponding work size	± 1,0	± 0,5	± 0,5	± 0,5	EN 98
(c) Warpage, related to diagonal calculated from the work sizes	± 1,0	± 0,5	± 0,5	± 0,5	EN 98
<i>Surface quality</i> <sup>2)</sup>	Min. 95 % of tiles shall be free from visible defects that would impair the appearance of a major area of tiles				EN 98

1) Not applicable for tiles having curved shapes.

2) Because of firing, slight variations from the standard colour are unavoidable. This does not apply to intentional irregularities of colour variation of the face of dust-pressed tiles of low water absorption (which can be unglazed, glazed or partly glazed) or to the colour variation

Table 3 (concluded)

	Surface <i>S</i> of the product (cm <sup>2</sup> )				Test according to
	<i>S</i> < 90	90 < <i>S</i> < 190	190 < <i>S</i> < 410	<i>S</i> > 410	
<b>Physical properties</b>					
<i>Water absorption</i> % by weight	Average $6 < E < 10$ Individual max. 11,0				EN 99
<i>Modulus of rupture</i> in N/mm <sup>2</sup>	Average > 18 min. 16				EN 100
<i>Scratch hardness of surface</i> (Mohs' scale)					
(a) glazed tiles	min. 5				EN 101
(b) unglazed tiles	min. 6				
<i>Abrasion resistance</i>					
(a) <i>Resistance to deep abrasion of unglazed tiles</i>	Removed volume in mm <sup>3</sup>				EN 102
(b) <i>Resistance to abrasion of glazed tiles</i>	According to the abrasion class indicated by the manufacturer				
Class I – IV					EN 154
<i>Co-efficient of linear thermal expansion from ambient temperature to 100 °C</i> (K <sup>-1</sup> )	max. $9 \times 10^{-6}$				EN 103
<i>Thermal shock resistance</i>	required				EN 104
<i>Crazing resistance</i> <sup>3)</sup> glazed tiles	required				EN 105
<i>Frost resistance</i>	Required if agreed				EN 202
<i>Moisture expansion unglazed tiles</i> mm/m	max. 0.6				EN 155
<b>Chemical properties</b>					
<i>Resistance to staining of glazed tiles</i>	min. Class 2				EN 122
Class 1 – 3					
<i>Resistance to household chemicals and swimming pool water cleansers, except to cleansing agents containing hydrofluoric acid and its compounds</i>					
(a) glazed tiles	min. Class B				EN 122
Class AA – D					
(b) unglazed tiles	required				EN 106
<i>Resistance to acids and alkalis (with the exception of hydrofluoric acid and its compounds)</i>					
glazed tiles	Required if agreed according to the chemical resistance class indicated by the manufacturer				EN 122
Class AA – D					
unglazed tiles	required <sup>4)</sup>				EN 106

3) Certain decorative effects may have a tendency to craze. These shall be identified by the manufacturer, in which case the crazing test given in EN 105 is not applicable.

4) If the hue becomes slightly different this is not considered to be chemical attack.