

INTERNATIONAL
STANDARD

ISO
8662-4

First edition
1994-12-15

**Hand-held portable power tools —
Measurement of vibrations at the
handle —**

Part 4:
Grinders
(standards.iteh.ai)

[ISO 8662-4:1994](https://standards.iso.org/iso-8662-4-1994)

<https://standards.iso.org/iso-8662-4-1994> *Machines à moteur portatives — Mesurage des vibrations au niveau des poignées*

Partie 4: Meuleuses



Reference number
ISO 8662-4:1994(E)

Foreword

ISO (the International Organization for Standardization) is a worldwide federation of national standards bodies (ISO member bodies). The work of preparing International Standards is normally carried out through ISO technical committees. Each member body interested in a subject for which a technical committee has been established has the right to be represented on that committee. International organizations, governmental and non-governmental, in liaison with ISO, also take part in the work. ISO collaborates closely with the International Electrotechnical Commission (IEC) on all matters of electrotechnical standardization.

Draft International Standards adopted by the technical committees are circulated to the member bodies for voting. Publication as an International Standard requires approval by at least 75 % of the member bodies casting a vote.

International Standard ISO 8662-4 was prepared by Technical Committee ISO/TC 118, *Compressors, pneumatic tools and pneumatic machines*, Subcommittee SC 3, *Pneumatic tools and machines*.

ISO 8662 consists of the following parts, under the general title *Hand-held portable power tools — Measurement of vibrations at the handle*:

- Part 1: *General*
- Part 2: *Chipping hammers and riveting hammers*
- Part 3: *Rock drills and rotary hammers*
- Part 4: *Grinders*
- Part 5: *Pavement breakers and hammers for construction work*
- Part 6: *Impact drills*
- Part 7: *Wrenches, screwdrivers and nut runners with impact, impulse or ratcheting action*
- Part 8: *Polishers and rotary, orbital or random sanders*
- Part 9: *Rammers*

© ISO 1994

All rights reserved. Unless otherwise specified, no part of this publication may be reproduced or utilized in any form or by any means, electronic or mechanical, including photocopying and microfilm, without permission in writing from the publisher.

International Organization for Standardization
Case Postale 56 • CH-1211 Genève 20 • Switzerland

Printed in Switzerland

- *Part 10: Nibblers and shears*
 - *Part 11: Fastener driving tools (nailers)*
 - *Part 12: Saws and files with oscillating, reciprocating or rotating action*
 - *Part 13: Die grinders*
 - *Part 14: Stone-working tools and needle scalers*
- Annex A of this part of ISO 8662 is for information only.

iTeh STANDARD PREVIEW
(standards.iteh.ai)

ISO 8662-4:1994

<https://standards.iteh.ai/catalog/standards/sist/b72c7e62-5cbc-4e48-9a5f-9019da7ae005/iso-8662-4-1994>

Introduction

This part of ISO 8662, which specifies a type test for the measurement of vibrations at the handles of hand-held portable grinders, supplements ISO 8662-1 which gives general specifications for the measurement of vibrations at the handles of hand-held portable power tools. It specifies the operation of the tool under type test and other requirements for the performance of the type test.

The principle of the operation of these power tools is that a driving medium causes an output spindle to rotate. The spindle is adapted to carry an abrasive device for material removal.

It has been found that vibrations generated by a grinder cutting or grinding a workpiece vary considerably. The variation is largely due to the variances in the unbalance of the machine with the grinding wheel mounted. The unbalance also changes when the wheel is in operation. In order to provide a method which gives good measurement reproducibility, the procedure adopted in this part of ISO 8662 uses a test wheel of known unbalance mounted on a machine and running free. The unbalance is chosen to be 40 % of the highest permissible unbalance according to ISO 6103. Preliminary investigations suggest that the values obtained when the machine is running free are usually correlated with measurements obtained when grinding. However, the procedures of ISO 5349 are required whenever exposure at the workplace is to be assessed.

Hand-held portable power tools — Measurement of vibrations at the handle —

Part 4: Grinders

1 Scope

This part of ISO 8662 specifies a laboratory method for measuring the vibrations at the handles of hand-held power-driven grinders. It is a type-test procedure for establishing the magnitude of vibration in the handle of a power tool fitted with a specified test wheel.

The power tools covered by this part of ISO 8662 may be pneumatically driven, or driven by other means. Typical tools are illustrated in figure 1.

This part of ISO 8662 does not apply to die grinders.

It is intended that the results be used to compare different models of the same type of power tool, i.e. power tools intended for use with the same grinding wheel (same diameter and same maximum peripheral speed). If an evaluation of vibration exposure is required, then measurements in a work situation will be required.

2 Normative references

The following standards contain provisions which, through reference in this text, constitute provisions of this part of ISO 8662. At the time of publication, the editions indicated were valid. All standards are subject to revision, and parties to agreements based on this part of ISO 8662 are encouraged to investigate the possibility of applying the most recent editions of the

standards indicated below. Members of IEC and ISO maintain registers of currently valid International Standards.

ISO 8662-1:1988, *Hand-held portable power tools — Measurement of vibrations at the handle — Part 1: General.*

European Standard EN 792-7, *Handheld non-electric power tools — Safety requirements — Part 7: Grinders.*

3 Quantities to be measured

The quantities to be measured are as follows:

- the root-mean-square (r.m.s.) acceleration in accordance with ISO 8662-1:1988, 3.1, presented as a weighted acceleration in accordance with ISO 8662-1:1988, 3.3;
- the rotational speed;
- the downward feed force.

4 Instrumentation

4.1 General

The specifications for the instrumentation given in ISO 8662-1:1988, 4.1 to 4.6, apply.

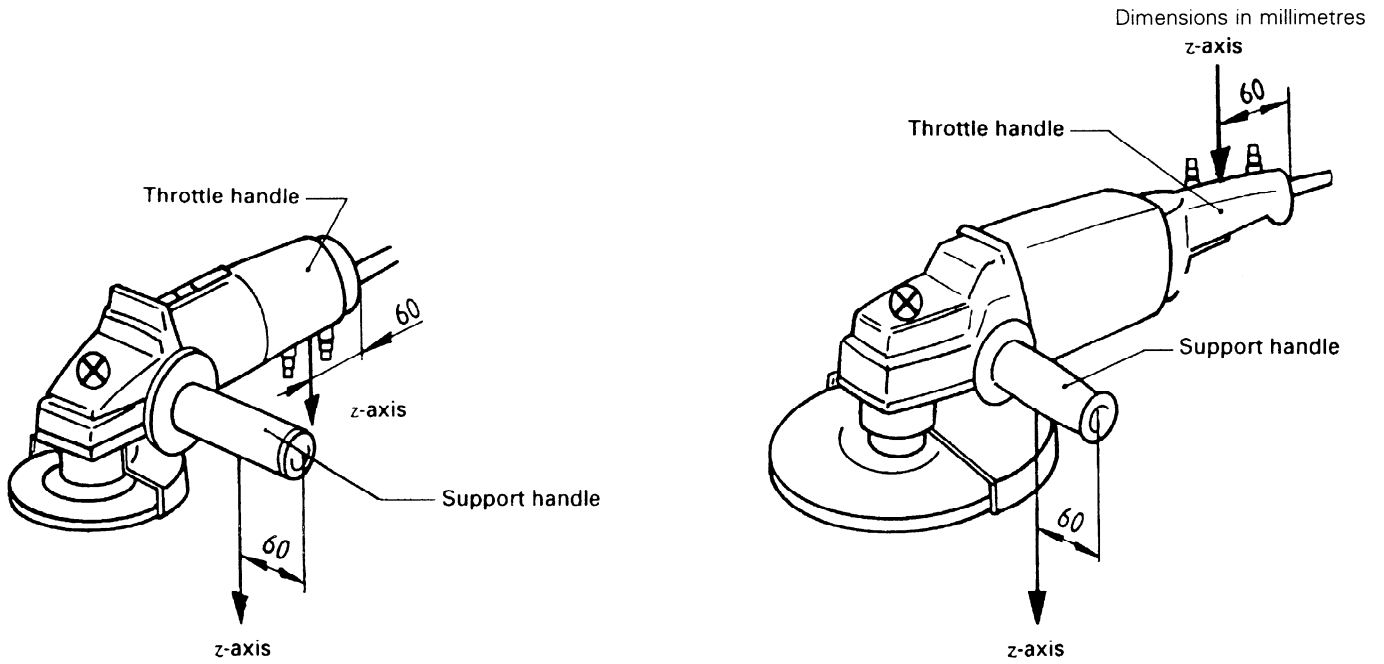

Angle grinders

iTeh STANDARD PREVIEW
(standards.iteh.ai)

ISO 8662-4:1994

<http://standards.iteh.ai/catalog/standards/sist/b72c7e62-5cbc-4e48-915f-9019da7ae005/iso-8662-4-1994>

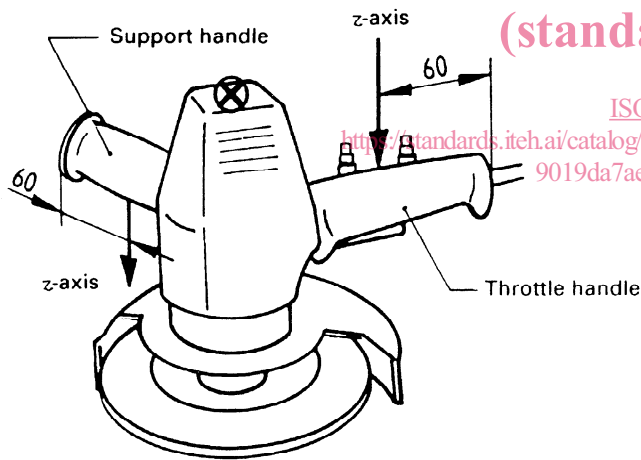

Vertical grinder

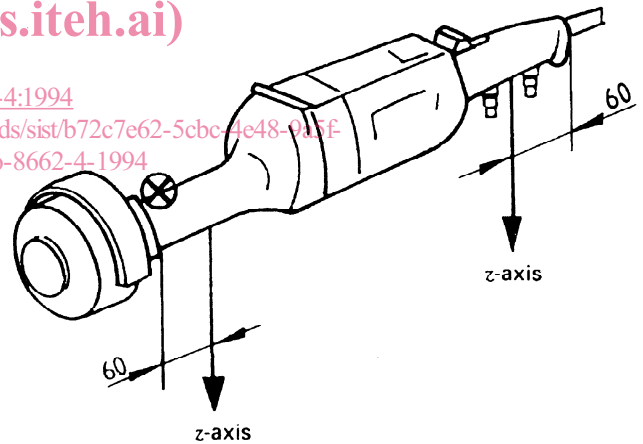

Straight grinder

Key



Examples of position of transducers



Point of application of feed force



Direction of measurement

Figure 1 — Measurement directions, examples of position of transducers and application of feed force

4.2 Transducer

The specification for the transducer given in ISO 8662-1:1988, 4.1, applies.

4.3 Mechanical filter

It is not normally necessary to use a mechanical filter for measurements according to this part of ISO 8662 (see ISO 8662-1:1988, 3.2).

4.4 Fastening of transducer

Fastening of the transducer shall be in accordance with ISO 8662-1:1988, 4.2. Small transducers may be glued to a flat surface using a suitable adhesive. In all cases, the fastening of the transducer shall be in accordance with the transducer manufacturer's instructions (see figure 2).

If the handle has a soft resilient cover, a clamp shall be tightened securely around it on which the transducer is mounted, or a special adaptor may be used.

If the tool has a resilient handle, the test report shall state the action taken, e.g. solid clamping, or use of adaptor.

4.5 Auxiliary equipment

The air pressure shall be measured using a manometer.

The rotational speed shall be measured using a tachometer with an accuracy of at least 1 %.

4.6 Calibration

Calibration shall be carried out in accordance with ISO 8662-1:1988, 4.8.

5 Measurement direction and measurement location

5.1 Measurement direction

Measurements shall be made on both handles in the z-direction (see figure 1). For straight grinders the z-direction is perpendicular to the axis of rotation. For vertical and angle grinders the z-direction is parallel to the axis of rotation.

ISO 8662-4:1994
<https://standards.iteh.ai/catalog/standards/sist/b72c7e62-5cbc-4e48-9a5f-9019da7ae005/iso-8662-4-1994>

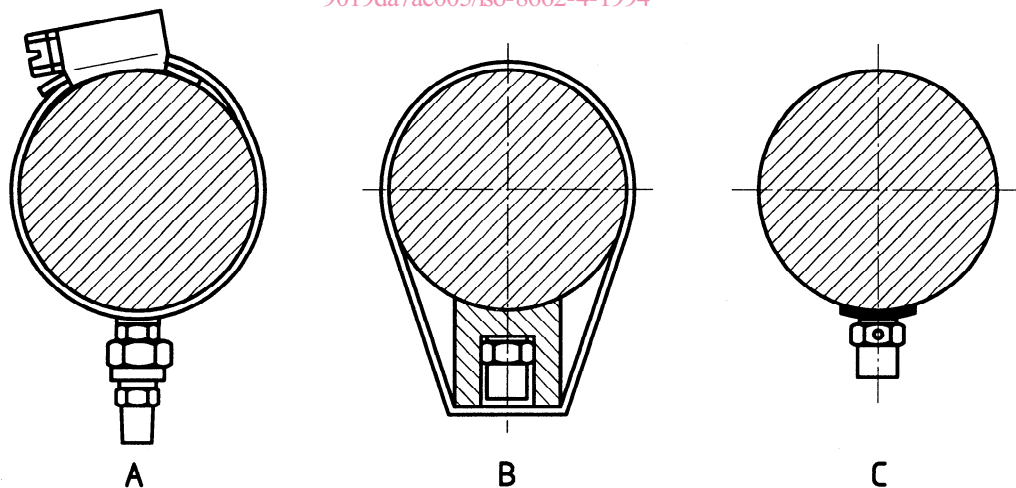

- A: By a hose clip to which a block is brazed or welded.
- B: By using an adaptor to which the transducer is screwed. The adaptor is mounted on the handle using plastic straps.
- C: By using a suitable adhesive or wax on a flat surface.

Figure 2 — Options for fastening of transducers

5.2 Measurement location

Handles may be attached to machines either rigidly or, in order to provide some vibration insulation, using an elastic mounting.

For rigidly mounted handles (where the centre of motion is inside the machine housing), vibration measurement can be carried out using one transducer attached preferably on the underside of the handle at a point in the middle of the grip surface. This point shall be 60 mm from the end of the grip (see figure 1).

Handles designed as antivibration devices may be elastically mounted on the machine. In such cases machine and handle may vibrate out of phase, resulting in a motion which cannot be adequately measured using a single transducer. For such handles measurements shall be made using two transducers mounted symmetrically approximately 100 mm apart about the centre point described above.

The transducers shall be mounted perpendicularly to the surface of the handle even if the surface is not exactly perpendicular to the ideal axis. Deviations of $\pm 15^\circ$ from this theoretical axis are acceptable. If the deviation is greater than $\pm 15^\circ$, an appropriate block should be used.

This part of ISO 8662 specifies the position of measurement on the handle, although it is accepted that higher values of vibration may be found at other positions. For type testing it is important that the location of the transducer is precisely specified.

6 Determination of working procedure

6.1 General

Measurements shall be carried out on a new, properly serviced and lubricated power tool.

During the test, the tool shall be held in a manner similar to that used when grinding (see figure 3).

6.2 Operation of the grinding machine

6.2.1 Pneumatic grinders

The air shall be supplied to pneumatic grinders by a hose having a length of at least 2 m and which is attached to the grinder via a threaded hose connector and is secured with a hose clip.

Pneumatic grinders shall be tested at the nominal load speed, i.e.

- a) for ungoverned machines, (50 ± 5) % of the rated no-load speed, and
- b) for governed machines, (80 ± 5) % of the rated no-load speed.

The nominal load speed is obtained by adjusting the air pressure. If the vibrational properties of the machine are influenced by the air pressure, the nominal load speed shall be obtained by some other appropriate means which does not modify the internal unbalance of the grinder.

NOTE 1 For angle grinders fitted with suspended handles (i.e. handles designed to reduce the transmission of vibration from the tool to the hand) it may be necessary to measure along an axis tangential to the cross-section of the handle at a number of different frequencies in order to examine the transmission properties of the handle.

It is important to note that the properties of such handles may be modified by reducing the air pressure used to achieve the nominal load speed.

6.2.2 Non-pneumatic grinders

The grinders shall be tested at the nominal load speed. The speed is determined in a preceding test by loading the machine, e.g. by braking or under working conditions, until rated power is reached.

The nominal load speed during the test shall be achieved by suitable means.

6.3 Test wheel

A test wheel, made of aluminium, whose specifications are indicated in figure 4 and tables 2 and 3, shall be mounted on the grinder with two orientations, 0° and 180° rotation about the wheel axis. A reference line shall be drawn on the wheel to mark these orientations.

The wheel shall be mounted concentrically with the grinder shaft, and original parts (e.g. flanges) shall be used. The test wheel shall be mounted with zero play. To achieve this, a concentric adaptor bushing as specified in table 1 and figure 4 can be used.

The unbalance of the test wheel can be obtained by drilling a hole of diameter e smaller than necessary, measuring the unbalance, and then increasing the size of the hole in stages until the required unbalance is obtained.

The density of the aluminium used in the test wheel shall be $\rho = 2\,720 \text{ kg/m}^3 \pm 20 \text{ kg/m}^3$. With the given tolerances, the tolerance of the unbalance shall be within ± 5 %.

If the tool is supplied with a wheel guard, this shall be fitted and the largest wheel which fits inside the guard shall be used.

For grinders designed to accept only specific discs such as diamond cutting wheels, measurements shall be made using these discs and not using a test wheel. The static unbalance of the disc shall be measured and stated in the test report.

6.4 Feed force

A force in accordance with table 4 plus a force equal to the weight of the machine shall be applied to a point on the tool as close as possible to the point at which the static force acts when grinding takes place.

The machine being suspended on a cord, the force can be applied using a weight (see figure 3) or, alternatively, a dynamometer can be attached to the cord. The application of force shall be achieved with minimum adaptation to the machine.

7 Measurement procedure and validity of measurements

7.1 Power supply

The air pressure of pneumatically powered tools shall be measured using a manometer.

7.2 Test procedure

7.2.1 Three skilled operators shall each carry out a series of two measurements in each orientation by unfastening and then refastening the test wheel (the sequence of measurements shall be 0°, 180°, 0°, 180°).

7.2.2 In addition, one measurement shall be made with the grinder running free at the test speed (see 6.2.1 and 6.2.2) with no test wheel mounted.

7.2.3 The duration of each test run shall be such that when stable operation has been established, the reading shall be carried out for not less than 8 s.

iTeh STANDARD PREVIEW
(standards.iteh.ai)

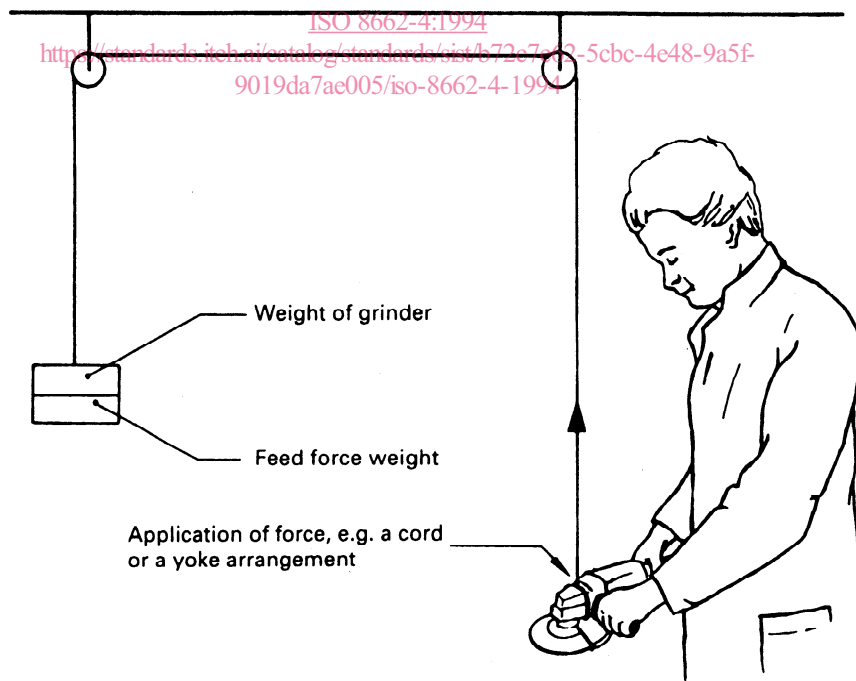

Figure 3 — Grinder — Working position of operator