



Standard Test Method for Alternating-Current Magnetic Properties of Amorphous Materials at Power Frequencies Using Wattmeter-Ammeter-Voltmeter Method with Sheet Specimens¹

This standard is issued under the fixed designation A 932/A932M; the number immediately following the designation indicates the year of original adoption or, in the case of revision, the year of last revision. A number in parentheses indicates the year of last reappraisal. A superscript epsilon (ϵ) indicates an editorial change since the last revision or reappraisal.

1. Scope

1.1 This test method covers tests for various magnetic properties of flat-cast amorphous magnetic materials at power frequencies (50 and 60 Hz) using sheet type specimens in a yoke type test fixture. It provides for testing using either single or multiple layer specimens.

NOTE 1—This test method has been applied only at frequencies of 50 and 60 Hz, but with proper instrumentation and application of the principles of testing and calibration embodied in the test method, it is believed to be adaptable to testing at frequencies ranging from 25 to 400 Hz.

1.2 This test method provides a test for specific core loss, specific exciting power and ac peak permeability at moderate and high flux densities, but is restricted to very soft magnetic materials with dc coercivities of 0.07 Oe [5.57 A/m] or less.

1.3 The test method also provides procedures for calculating ac peak permeability from measured peak values of total exciting currents at magnetic field strengths up to about 2 Oe [159 A/m].

1.4 Explanation of symbols and abbreviated definitions appear in the text of this test method. The official symbols and definitions are listed in Terminology A 340.

1.5 This test method shall be used in conjunction with Practice A 34.

1.6 The values stated in either customary units (practical cgs & inch-pound) or SI units are to be regarded separately as standard. Separate derivations are included for each of the unit systems. However, within the general text, SI units are shown in brackets. The values stated in each system are not exact equivalents: therefore, each system shall be used independently of the other. Combining values from the two systems may result in nonconformance with the test method.

1.7 *This standard does not purport to address all of the safety concerns, if any, associated with its use. It is the responsibility of the user of this standard to establish appropriate safety and health practices and determine the applicability of regulatory limitations prior to use.*

¹ This test method is under the jurisdiction of ASTM Committee A-6 on Magnetic Properties and is the direct responsibility of Subcommittee A06.01 on Test Methods.

Current edition approved Nov. 10, 1995. Published January 1996.

2. Referenced Documents

2.1 ASTM Standards:

A 34 Practice for Procurement, Testing and Sampling of Magnetic Materials²

A 340 Terminology of Symbols and Definitions Relating to Magnetic Testing²

A 343 Test Method for Alternating-Current Magnetic Properties of Materials at Power Frequencies Using Wattmeter-Ammeter-Voltmeter Method and 25-cm Epstein Frame²

A 804/A804M Test Methods for Alternating-Current Magnetic Properties of Materials at Power Frequencies Using Sheet-Type Test Specimens²

A 876 Specification for Flat-Rolled, Grain-Oriented, Silicon-Iron, Electrical Steel, Fully Processed Types²

A 876M Specification for Flat-Rolled, Grain-Oriented, Silicon-Iron, Electrical Steel, Fully Processed Types (Metric)²

A 901 Specification for Amorphous Magnetic Core Alloys, Semi-Processed Types²

A 912 Test Method for Alternating-Current Magnetic Properties of Amorphous Materials at Power Frequencies Using Wattmeter-Ammeter-Voltmeter Methods with Toroidal Specimens²

C 693 Test Method for Density of Glass by Buoyancy³

3. Terminology

3.1 The definitions of terms, symbols, and conversion factors relating to magnetic testing, used in this test method, are found in Terminology A 340.

3.2 Definitions of Terms Specific to This Standard:

3.2.1 *sheet specimen*—a rectangular specimen comprised of a single piece of material or parallel multiple strips of material arranged in a single layer.

3.2.2 *specimen stack*—test specimens (as in 3.2.1) arranged in a stack two or more layers high.

4. Significance and Use

4.1 This test method provides a satisfactory means of determining various ac magnetic properties of amorphous magnetic materials. It was developed to supplement the testing

² Annual Book of ASTM Standards, Vol 03.04.

³ Annual Book of ASTM Standards, Vol 15.02.

of toroidal and Epstein specimens. For testing toroidal specimens of amorphous materials, refer to Test Method A 912.

4.2 The procedures described herein are suitable for use by manufacturers and users of amorphous magnetic materials for materials specification acceptance and manufacturing control.

NOTE 2—This test method has been principally applied to the magnetic testing of thermally, magnetically annealed and flattened amorphous strip at 50 and 60 Hz. Specific core loss at 13 or 14 kG [1.3 or 1.4T], specific exciting power at 13 or 14 kG [1.3 or 1.4T], and the flux density, B, at 1 Oe [79.6 A/m] are the recommended parameters for evaluating power grade amorphous materials.

5. Interferences

5.1 Because amorphous magnetic strip is commonly less than 0.0015 in. [0.04 mm] thick, surface roughness tends to have a large effect on the cross sectional area and the cross section in some areas can be less than the computed average. In such cases the test results using a single strip specimen can be substantially different from that measured with a stack of several strips. One approach to minimize the error due to surface roughness is to use several strips in a stack to average out the variations. The penalty for stacking is that the active magnetic path length of the specimen stack becomes poorly defined. The variation of the active length increases with each additional strip in the stack. Moreover, the active length for stacked strips tends to vary from sample to sample. As the stack height increases, the error due to cross-sectional variations diminishes but that due to length variations increases with the overall optimum at about four to six layers. The accuracy for stacked strips is never as good as for a single layer of smooth strip.

5.2 Some amorphous magnetic materials are highly magnetostrictive. This is an additional potential source of error

because even a small amount of surface loading, twisting or flattening will cause a noticeable change in the measured values.

6. Basic Test Circuit

6.1 Fig. 1 provides a schematic circuit diagram for the test method. A power source of precisely controllable ac sinusoidal voltage is used to energize the primary circuit. To minimize flux-waveform distortion, current ratings of the power source and of the wiring and switches in the primary circuit shall be such as to provide very low impedance relative to the impedance arising from the test fixture and test specimen. Ratings of switches and wiring in the secondary circuit also shall be such as to cause negligible voltage drop between the terminals of the secondary test winding and the terminals of the measuring instruments.

7. Apparatus

7.1 The test circuit shall incorporate as many of the following components as are required to perform the desired measurements.

7.2 Yoke Test Fixture—Fig. 2 shows a line drawing of a yoke fixture. Directions concerning the design, construction, and calibration of the fixture are given in 7.2.1, 7.2.2, Annex A1, Annex A2, and Annex A3.

7.2.1 Yoke Structure—Various dimensions and fabrication procedures in construction are permissible. Since the recommended calibration procedure requires correlation with the 25-cm Epstein test, the minimum inside dimension between pole faces must be at least 22 cm [220 mm]. The thickness of the pole faces should be not less than 2.5 cm [25 mm]. To minimize the influences of coil-end and pole-face effects, the yokes should be thicker than the recommended minimum. For

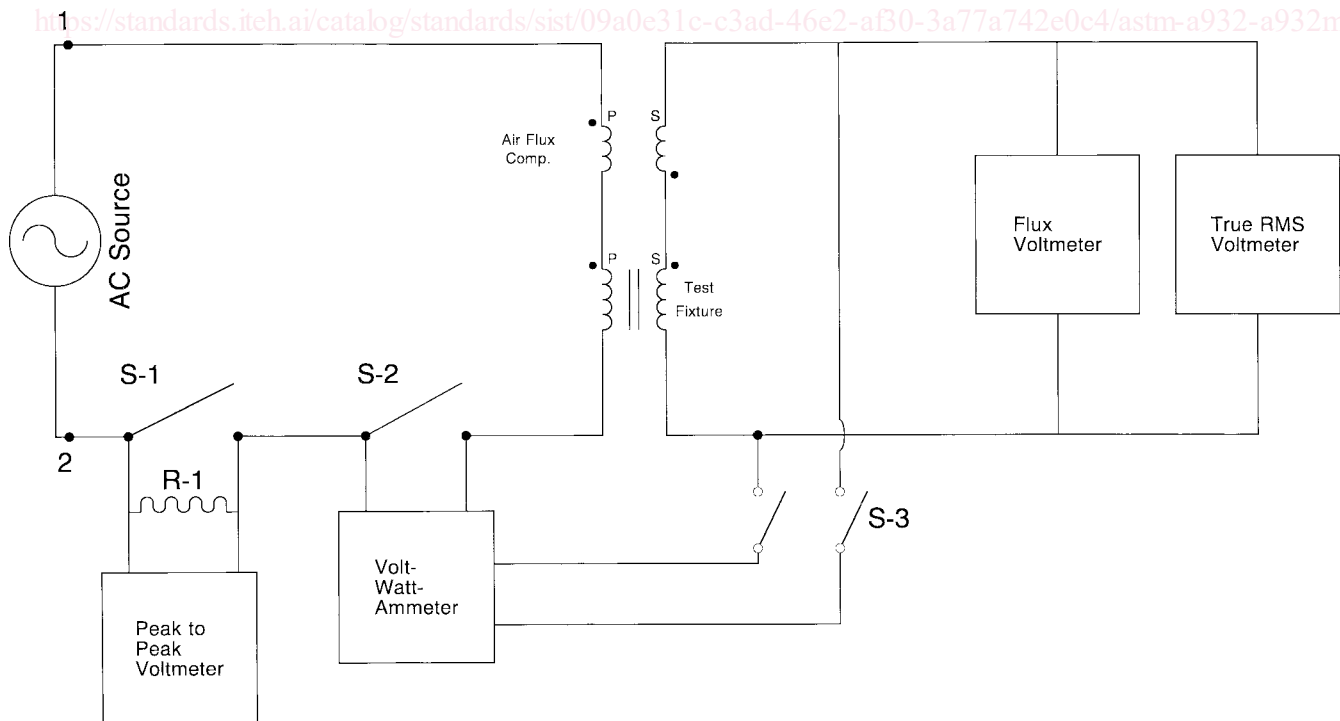

FIG. 1 Basic Block Circuit Diagram of the Wattmeter Method

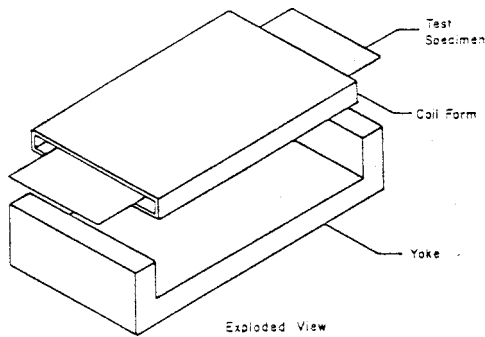

FIG. 2 Single Yoke Fixture (Exploded View)

calibration purposes, it is suggested that the width of the fixture be at least 12.0 cm [120 mm] which corresponds to the combined width of 4 Epstein-type specimens.

7.2.2 *Test Windings*—The test windings, which shall consist of a primary (exciting) winding and a secondary (potential) winding, shall be uniformly and closely wound on a non-magnetic, non-conducting coil form and each shall span the greatest possible distance between the pole faces of the yoke fixture. It is recommended that the number of turns in the primary and secondary windings be equal. The number of turns may be chosen to suit the instrumentation, mass of specimen and test frequency. The secondary winding shall be the innermost winding. The primary and secondary turns shall be wound in the same direction from a common starting point at one end of the coil form. Also, to minimize self-impedances of the windings, the opening in the coil form should be no greater than that required to allow easy insertion of the test specimen. Construction and mounting of the test coil assembly must be such that the test specimen will be maintained without mechanical distortion in the plane established by the pole faces of the yoke(s) of the test fixture.

7.3 *Air Flux Compensator*—To provide a means of determining intrinsic flux density in the test specimen, an air-core mutual inductor shall constitute part of the test-coil system. The respective primary and secondary windings of the air-core inductor and the test-specimen coil shall be connected in series and the voltage polarities of the secondary windings shall be in opposition. By proper adjustment of the mutual inductance of the air-core inductor, the average voltage developed across the combined secondary windings is proportional to the intrinsic flux density in the test specimen. Directions for construction and adjustment of the air-core mutual inductor for air-flux are found in Annex A3.

7.4 *Flux Voltmeter, V_f* —A full-wave, true average responding voltmeter, with scale readings in average volts times $\pi > \sqrt{2} / 4$ so that its indications will be identical with those of a true rms voltmeter on a pure sinusoidal voltage, shall be provided for evaluating the peak value of the test flux density. To produce the estimated precision of test under this test method, the full-scale meter errors shall not exceed 0.25 % (Note 3). Either digital or analog flux voltmeters are permitted. Use of a digital flux voltmeter with high input impedance (typically, 10 M Ω) is recommended to minimize loading effects and to reduce instrument loss compensation. If an analog flux voltmeter is used, its input resistance shall be greater than 10 000 Ω/V of full scale indication. Voltage ranges

and number of significant digits shall be consistent with the accuracy specified above. Care shall be taken to avoid errors due to temperature and frequency effects in the instrument.

NOTE 3—Inaccuracies in setting the test voltage produce errors approximately two times as large in the specific core loss.

7.5 *RMS Voltmeter, V_{rms}* —A true rms-indicating voltmeter shall be provided for evaluating the form factor of the voltage induced in the secondary winding of the test fixture and for evaluating the instrument losses. The accuracy of the rms voltmeter shall be the same as specified for the flux voltmeter. Either digital or analog rms voltmeters are permitted. The normally high input impedance of digital rms voltmeters is desirable to minimize loading effects and to reduce the magnitude of instrument loss compensations. The input resistance of an analog rms voltmeter shall not be less than 10 000 Ω/V of full-scale indication.

7.6 *Wattmeter, W* —The full-scale accuracy of the wattmeter shall not be lower than 0.25 % at the test frequency and unity power factor. The power factor encountered by a wattmeter during a core loss test on a specimen is always less than unity and, at flux densities far above the knee of the magnetization curve, approaches zero. The wattmeter must maintain 1.0 % accuracy at the lowest power factor which is presented to it. Variable scaling devices may be employed to cause the wattmeter to indicate directly in units of specific core loss if the combination of basic instruments and scaling devices conforms to the specifications stated here.

7.6.1 *Electronic Digital Wattmeter*—An electronic digital wattmeter is preferred in this test method because of its digital read-out and its capability for direct interfacing with electronic data acquisition systems. A combination True RMS Voltmeter-Wattmeter-RMS Ammeter is acceptable to reduce the number of instruments connected in the test circuit.

7.6.1.1 The voltage input circuitry of the electronic digital wattmeter must have an input impedance sufficiently high so that connection to the secondary winding of the test fixture during testing does not change the terminal voltage of the secondary by more than 0.05 %. Also, the voltage input circuitry must be capable of accepting the maximum peak voltage which is induced in the secondary winding during testing.

7.6.1.2 The current input circuitry of the electronic digital wattmeter should have as low an input impedance as possible, preferably no more than 0.1 Ω , otherwise the flux waveform distortion tends to be excessive. The effect of moderate waveform distortion is addressed in 10.3. The current input circuitry must be capable of accepting the maximum rms current and the maximum peak current drawn by the primary winding of the test transformer when core loss tests are being performed. In particular, since the primary current will be very nonsinusoidal (peaked) if core loss tests are performed on a specimen at flux densities above the knee of the magnetization curve, the crest factor capability of the current input circuitry should be 5 or more.

7.6.2 *Electrodynamometer Wattmeter*—A reflecting type astatic electro-dynamometer wattmeter is permitted as an alternative to an electronic wattmeter.

7.6.2.1 The sensitivity of the electrodynamic wattmeter must be such that the connection of the potential circuit of the wattmeter, during testing, to the secondary winding of the test fixture does not change the terminal voltage of the secondary by more than 0.05 %. Also, the resistance of the potential circuit of the wattmeter must be sufficiently high so that the inductive reactance of the potential coil of the wattmeter in combination with the leakage reactance of the secondary circuit of the test fixture does not introduce an additional phase angle error in the measurements. Should the impedance of this combined reactance at the test frequency exceed 1Ω per 1000Ω of resistance in the wattmeter-potential circuit, the potential circuit must be compensated for this reactance.

7.6.2.2 The impedance of the current coil of the electrodynamic wattmeter should not exceed 2.0Ω . If flux waveform distortion tends to be excessive, this impedance should be not more than 0.1Ω . The rated current carrying capacity of the current coil must be compatible with the maximum rms primary current to be encountered during core loss testing.

7.6.3 *Waveform Calculator*—The waveform calculator used in combination with a digitizing oscilloscope is useful for core loss measurements. See Annex A4 for details regarding these instruments. There are added benefits in that this equipment is able to measure, compute and display the rms, average and peak values for current and flux voltage as well as measure the core loss and excitation power demand.

7.6.3.1 The normally high input impedance of these instruments (approximately $1\text{ M}\Omega$) precludes possible errors due to instrument loading. There is a requirement that the current and flux sensing leads must be connected in the proper phase relationship.

7.7 *RMS Ammeter*—A true rms ammeter is required if measurements of exciting current are to be made. The preferred method for measuring the rms current is to measure the voltage drop across a low value, non-inductive resistor in the primary circuit using a true rms-responding voltmeter. Electronic wattmeters commonly are also true rms ammeters, but a separate instrument may be needed.

7.8 *Devices for Peak-Current Measurement*—A means of determining the peak value of the exciting current is required if an evaluation of peak permeability is to be made by the peak-current method. The use of an air-core mutual inductor for this purpose must be avoided because of the error it would introduce in this test due to increased waveform distortion.

7.8.1 The peak-current measurement may be made with a voltmeter whose indications are proportional to the peak-to-peak value of the voltage drop that results when the exciting current flows through a standard resistance of low value connected in series with the primary winding of the test transformer. This peak-to-peak reading voltmeter shall have a nominal full scale accuracy of at least 3 % at the test frequency and be able to accommodate voltage with a crest factor of 5 or more. Care must be exercised that the standard resistor (usually in the range 0.1 to 1.0Ω) carrying the exciting current has adequate current-carrying capacity and is accurate to at least 0.1 %. It shall have negligible variation with temperature and frequency under the conditions applicable to this test method.

If desired, the value of the resistor may be such that the peak-reading voltmeter indicates directly in terms of peak magnetic field strength, provided that the resistor conforms to the limitations stated above.

7.9 *Power Supply*—A source of sinusoidal test power of low internal impedance and excellent voltage and frequency stability is required for this test.

7.9.1 An electronic power source consisting of a low-distortion oscillator working into a very linear amplifier of about 75 VA rating is an acceptable source of test power. The line power for the electronic oscillator and amplifier should come from a voltage-regulated source, to ensure voltage stability within 0.1 %, and the output of the system should be monitored with an accurate frequency-indicating device to see that control of the frequency is maintained to within 0.1 % or better. It is permissible to use an amplifier with negative feedback to reduce the waveform distortion. A properly designed system will maintain the form factor at $\pi > \sqrt{2}/4$ until the test specimen saturates.

7.9.2 A suitable non-electronic power supply may be used. The voltage for the test circuit may be made adjustable by use of a flux density regulator or variable adjustable transformer with a tapped transformer between the source and the test circuit, or by generator field control. The harmonic content of the voltage output from the source under the heaviest test load should not exceed 1.0 %. Voltage stability within 0.1 % is necessary for precise work. The frequency of the source should be accurately controlled within 0.1 % of the nominal value.

8. Specimen Preparation

8.1 The type of test fixture and its dimensions govern the dimensions of permissible test specimens. The minimum length of a specimen shall be no less than the outside dimension of the distance over the pole faces of the test fixture. The length of the specimen shall be equal in length to the specimens used in calibration of the fixture. This length is preferably 30 cm [300 mm]. Also, the stack height shall be the same as that used in calibration of the fixture. The preferred stack height is four strips. For maximum accuracy, the specimen width should be equal to the width of the yoke. As a minimum, it is recommended that the specimen width be at least one-half of the yoke width.

8.2 The specimen shall have square ends, and a length tolerance of 0.1 %.

8.3 The specimen shall be annealed prior to testing in accordance with the appropriate ASTM Material Specification such as Specification A 901 or as agreed upon by manufacturer and purchaser. The threefold purpose of the anneal is to flatten the specimen, remove the residual stress, and to impart the desired magnetic anisotropy. The details of a typical magnetic annealing cycle and fixture are given in Annex A5.

9. Procedure

9.1 *Initial Determinations*—Prior to testing, check length of each specimen for conformity within 0.1 % of the desired length. Discard specimens showing evidence of mechanical damage. Weigh and record the mass of each specimen to an accuracy of 0.1 %.

9.2 *Specimen Placement*—When placed into the test fixture,

the test specimen must be centered on the longitudinal and transverse axes of the test coil. Due to the high stress sensitivity of some amorphous materials, any loading force on the test specimen should be avoided.

9.3 Demagnetization—The specimen should be demagnetized before measurements of any magnetic property are made. With the required apparatus connected as shown in Fig. 1 and with switches S1 and S2 closed and S3 open, accomplish this demagnetization by initially applying a voltage from the power source of the primary circuit that is sufficient to magnetize the specimen to a flux density above the knee of its magnetization curve (this flux density may be determined from the reading of the flux voltmeter by means of the (Eq 1) or (Eq 13)) and then decreasing the voltage slowly and smoothly (or in small steps) to a very low flux density. After demagnetization, test promptly at the desired test points, performing the tests in order of increasing flux density values.

9.4 Setting Induction—With switches S1 and S3 closed, and S2 open, increase the voltage of the power supply until the flux voltmeter indicates the value of voltage calculated to give the desired test flux density in accordance with (Eq 1) or (Eq 13). Because the action of the air-flux compensator causes a voltage equal to that which would be induced in the secondary winding by the air flux to be subtracted from that induced by the total flux in the secondary, the flux density calculated from the voltage indicated by the flux voltmeter will be the intrinsic flux density, B_i .

9.5 Core Loss—When the voltage indicated by the flux voltmeter has been adjusted to the desired value, read the wattmeter.

9.6 Specific Core Loss—Obtain the specific core loss of the specimen using the equations and instructions given in 10.2 and 11.2.

9.7 Secondary RMS Voltage—Read the rms voltmeter with switches S1 closed, S2 and S3 open, and the voltage indicated by the flux voltmeter adjusted to the desired value. On truly sinusoidal voltage, both voltmeters will indicate the same value, showing that the form factor of the induced voltage is $\pi > \sqrt{2}/4$. Determining the flux density from the reading of a flux voltmeter assures that the correct value of peak flux density is achieved in the specimen and, hence, that the hysteresis component of the core loss is correct even if the waveform is not strictly sinusoidal. If the reading of the rms voltmeter deviates from the reading of the flux voltmeter by more than 1 % (or the form factor deviates from $\pi > \sqrt{2}/4$ by more than 1 %), the value of the specific core loss shall be corrected. The equations for correction for waveform distortion are given in 10.3. The test methods for determining the percentages of eddy current loss and hysteresis loss are given in Annex A6.

9.8 Peak Current—Because the peak current in this measurement is seldom above 100 mA and is normally less than 10 mA, it is best measured using a peak-reading voltmeter and a precision 0.1 or 1.0 Ω resistor (R1 in Fig. 1). When peak flux density at a given magnetic field strength is required, open S1 to insert R1 into the primary circuit, close S2 to protect the wattmeter from the possibility of excessive current, open S3 to minimize secondary loading and adjust the voltage to the

power supply such that the peak reading voltmeter indicates that the necessary value of the peak current has been established. Observe on the flux voltmeter the value of flux volts induced in the secondary winding of the test fixture. The flux density corresponding to the observed flux volts may be computed using equation (1) or equation (13). The peak permeability is calculated using equations (10), (11), or (12) or else equations (19) and (20).

9.9 RMS Current—To measure the rms current, a true rms voltmeter is substituted for the peak reading voltmeter as described in 9.8.

10. Calculations (Customary Units)

10.1 Flux Volts—Calculate the flux volts, E_f , induced in the secondary winding of the test fixture corresponding to the desired intrinsic flux density in the test specimen from the following equation:

$$E_f = (\pi\sqrt{2})B_iN_2Af \times 10^{-5} \quad (1)$$

where:

- B_i = maximum intrinsic flux density, kG,
- A = effective cross-sectional area of the test specimen, cm^2 ,
- N_2 = number of turns in secondary winding, and
- f = frequency, Hz.

Cross-sectional area of the test specimen, $A \text{ cm}^2$, is determined as follows:

$$A = m/(\delta l) \quad (2)$$

where:

- m = total mass of specimen, g,
- l = actual length of specimen, cm, and
- δ = standard assumed density of specimen material, g/cm^3 .

10.2 Specific Core Loss—To obtain specific core loss in watts per unit mass of the specimen, power expended in the secondary of the test circuit and included in wattmeter indication must be eliminated prior to dividing by the active mass of the specimen (Note 4). The equation for calculating specific core loss, $P_{c(B;f)}$ in watts per pound, for a specified flux density, B , and frequency, f , is as follows:

$$P_{c(B;f)} = 453.6[(N_1P_c/N_2) - (E_2^2/R)]/m_c \quad (3)$$

where:

- P_c = core loss indicated by the wattmeter, W,
- E_2 = rms volts for the secondary circuit, V,
- R = parallel resistance of wattmeter potential circuit and all other loads connected to the secondary circuit, Ω ,
- N_1 = number of turns in primary winding,
- N_2 = number of turns in secondary winding, and
- m_c = active mass of specimen, g.

The active mass, m_c , in grams, of the specimen is determined as follows:

$$m_c = l_c m/l \quad (4)$$

where:

- l_c = effective core loss path length as determined by the calibration procedures of Annex A2, cm,
- m = total mass of specimen, g, and
- l = actual length of specimen, cm.

NOTE 4—Some wattmeters have either sufficiently high resistance or compensating circuits which eliminate the need to subtract the secondary circuit load.

10.3 *Form Factor Correction*—A characteristic of standard amorphous materials is that the knee of the magnetization curve drops to a lower flux density value and the specific power loss increases. About 80 % of this increase is in the form of higher hysteresis loss. Therefore, the error due to waveform distortion will be much smaller than with most electrical steels. If the form factor distortion is greater than 5 %, the material is probably not usable at that flux density. However, the eddy-current component of the core loss will be in error depending on the deviation of the induced voltage from the desired sinusoidal wave shape. Because the eddy loss fraction (percentage) in amorphous materials can vary from 0.2 to 0.8 (20 to 80 %), the correction for wave form distortion may be appreciable. The percent error in form factor is given by the following equation (Note 5):

$$F = 100(E_2 - E_p)/E_f \tag{5}$$

assuming (Note 6) that:

$$\text{Observed } P_{c(B,f)} = [(\text{corrected } P_{c(B,f)})h/100] + [(\text{corrected } P_{c(B,f)})Ke/100] \tag{6}$$

$$\text{Corrected } P_{c(B,f)} = (\text{observed } P_{c(B,f)})100/(h + Ke) \tag{7}$$

where:

- $observed P_{c(B,f)}$ = specific core loss calculated by the equations in 10.2,
- h = percentage hysteresis loss at flux density B ,
- e = percentage eddy-current loss at flux density B , and
- K = $(E_2/E_p)^2$.

Obviously, $h = 100 - e$ if residual losses are considered negligible. The values of h and e in the above equation are not critical when waveform distortion is low. Values for the class of material may be obtained by core loss separation tests made by either the two-frequency method or by the two form factor method.

NOTE 5—It is recommended that tests made under conditions where the percent error in form factor, F , is greater than five percent be considered as likely to be in error by an excessive amount, and that such conditions be avoided.

NOTE 6—In determining the form factor error, it is assumed that the hysteresis component of core loss will be independent of the form factor if the maximum value of flux density is at the correct value (as it will be if a flux voltmeter is used to establish the value of the flux density) but that the eddy-current component of core loss, being a function of the rms value of the voltage, will be in error for nonsinusoidal voltages. While it is strictly true that frequency or form factor separations do not yield true values for the hysteresis and eddy-current components, yet they do separate the core loss into two components, one which is assumed to vary as the second power of the form factor and the other which is assumed to be unaffected by form factor variations. Regardless of the academic difficulties associated with characterizing these components as hysteresis

and eddy-current loss, it is observed that the equation for correcting core loss for waveform distortion of voltage based on the percentages of first-power and second-power of frequency components of core loss does accomplish the desired correction under all practical conditions if the form factor is accurately determined and the distortion not excessive.

10.4 *Specific Exciting Power RMS*—The exciting power in rms Volt-Amperes per pound, is:

$$P_{z(B,f)} = 453.6 \times I_{rms} \times E_2/m_z \tag{8}$$

where:

- I_{rms} = rms primary current, Amperes
- E_2 = rms secondary voltage, Volts
- m_z = active mass of specimen, g.

The active mass, m_z , in grams, of the specimen is determined as follows:

$$m_z = l_z m/l \tag{9}$$

where:

- l_z = effective exciting power path length as determined by the calibration procedures of Annex A2, cm,
- m = total mass of specimen, g, and
- l = actual length of specimen, cm.

10.5 *Peak Current*—The peak exciting current, I_p , in amperes, may be computed from measurements made using the standard resistor and peak to peak-reading voltmeter as follows:

$$I_p = E_{p-p}/(2R_1) \tag{10}$$

where:

- E_{p-p} = peak-to-peak voltage indicated by peak to peak-reading voltmeter, V, and
- R_1 = resistance of standard resistor, Ω .

10.6 *Peak Magnetic Field Strength*—The peak magnetic field strength, H_p , in oersteds, may be calculated as follows:

$$H_p = 0.4\pi N_1 I_p / l_2 \tag{11}$$

where:

- N_1 = number of turns in primary winding of test fixture,
- I_p = peak exciting current, A, and
- l_2 = effective peak magnetic field strength path length as determined by calibration procedures of Annex A2, cm.

10.7 *Peak Permeability*—To obtain correspondence with dc determinations, peak exciting current, I_p , or peak magnetizing strength, H_p , values for calculating peak permeability are customarily determined only at flux densities that are sufficiently above the knee of the magnetization curve that the core loss component of exciting current has negligible influence on the peak value of exciting current. Peak permeability, μ_p , is determined as follows:

$$\mu_p = B_i/H_p \tag{12}$$

where:

- B_i = intrinsic flux density, G,
- H_p = peak magnetic field strength, Oe.

11. Calculations (SI Units)

11.1 *Flux Volts*—Calculate the flux volts, E_f , induced in the secondary winding of the test fixture corresponding to the