



Designation: E 1059 – 91 (Reapproved 1996)

## Standard Practice for Designating Shapes and Sizes of Nongraphite Counter Electrodes<sup>1</sup>

This standard is issued under the fixed designation E 1059; the number immediately following the designation indicates the year of original adoption or, in the case of revision, the year of last revision. A number in parentheses indicates the year of last reapproval. A superscript epsilon ( $\epsilon$ ) indicates an editorial change since the last revision or reapproval.

### 1. Scope

1.1 This practice describes a number of specific nongraphite counter electrode shapes and sizes that are useful in spectrochemical analysis.

1.2 *This standard does not purport to address all of the safety concerns, if any, associated with its use. It is the responsibility of the user of this standard to establish appropriate safety and health practices and determine the applicability of regulatory limitations prior to use.*

### 2. Terminology

#### 2.1 Definition:

2.1.1 *counter electrode*—the electrode, in any analytical pair, that is used opposite to the self-electrode or supporting electrode and that is not composed of the specimen to be analyzed.

### 3. Summary of Practice

3.1 The practice designates nongraphite counter electrodes

and provides dimensional specifications.

### 4. Significance and Use

4.1 This practice is intended as a reference for spectrochemical methods that utilize nongraphite electrodes. One of the electrode shapes in this practice should be employed and referenced in a method. If this is not possible, the method should include the specifications for the electrode used.

4.2 This practice should be referenced in a method by including a statement such as the following in the section on Reagents and Materials:

*Counter Electrode*—The electrode shall conform to Type (insert the Type designation from this practice) as shown in Practice E 1059.

### 5. Materials and Dimensions

5.1 The materials and dimensions of the counter electrodes are given in Fig. 1, along with the tolerances where applicable.

5.1.1 The composition of these electrodes, if they have been established, are given in Fig. 1.

### 6. Keywords

6.1 counter electrodes; electrodes

<sup>1</sup> This practice is under the jurisdiction of ASTM Committee E-1 on Analytical Chemistry for Metals, Ores and Related Materials and is the direct responsibility of Subcommittee E01.20 on Fundamental Practices.

Current edition approved Sept. 15, 1991. Published November 1991. Originally published as E 1059 – 85. Last previous edition E 1059 – 85.

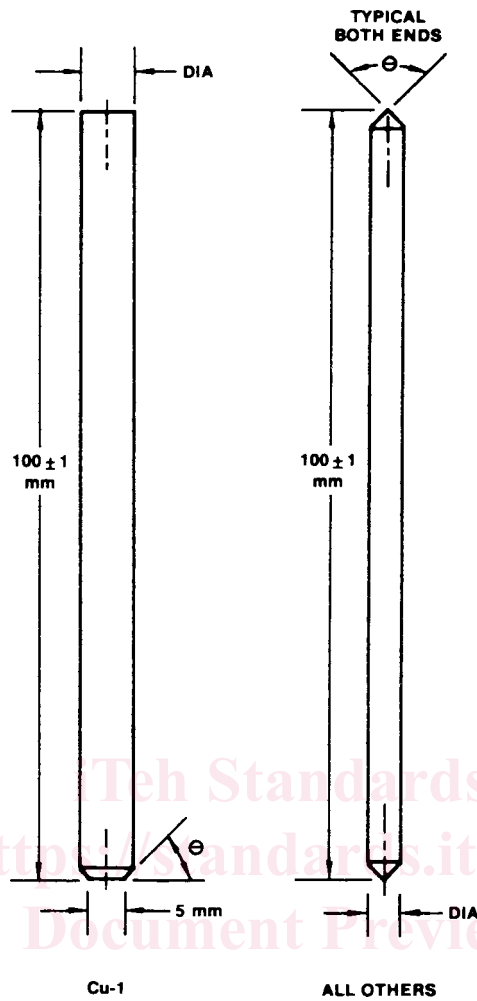

ASTM E1059-91(1996)

Type	Diameter (Dia) mm	[ominus] Degrees	Material
Ag-1	4.76	90	Fine Silver
Ag-2	6.35	90	Fine Silver
Cu-1	6.0	45	High Purity Copper Rod
Fe-1	4.76	90	Pure Iron
Fe-2	6.35	90	Pure Iron Drill Rod
Ni-1	4.76	90	Pure Nickel
Ni-2	6.35	90	Pure Nickel
W-1	6.0	90	Pure Tungsten
Thw-1	2.38	60	2 % Thoriated Tungsten
Thw-2	2.38	15	2 % Thoriated Tungsten
Thw-3	1.5	30	2 % Thoriated Tungsten
Thw-4	6.15	30	2 % Thoriated Tungsten
Thw-5	3.0	30	2 % Thoriated Tungsten

NOTE 1—All diameter tolerances are  $\pm .05$  mm.

FIG. 1 Recommended Shapes and Sizes of Nongraphite Counter Electrodes