

INTERNATIONAL STANDARD

ISO
8686-5

First edition
1992-08-15

Cranes — Design principles for loads and load combinations —

Part 5 : Overhead travelling and portal bridge cranes

iTeh STANDARD PREVIEW

(standards.iteh.ai)
Appareils de levage à charge suspendue — Principes de calcul des charges et des combinaisons de charge —

Partie 5 : Ponts roulants et ponts portiques

<https://standards.iteh.ai/catalog/standards/sist/d21761be-ddd6-4912-9f51-6127acfe772f/iso-8686-5-1992>



Reference number
ISO 8686-5 : 1992 (E)

Foreword

ISO (the International Organization for Standardization) is a worldwide federation of national standards bodies (ISO member bodies). The work of preparing International Standards is normally carried out through ISO technical committees. Each member body interested in a subject for which a technical committee has been established has the right to be represented on that committee. International organizations, governmental and non-governmental, in liaison with ISO, also take part in the work. ISO collaborates closely with the International Electrotechnical Commission (IEC) on all matters of electrotechnical standardization.

Draft International Standards adopted by the technical committees are circulated to the member bodies for voting. Publication as an International Standard requires approval by at least 75 % of the member bodies casting a vote.

International Standard ISO 8686-5 was prepared by Technical Committee ISO/TC 96, *Cranes*, Sub-Committee SC 9, *Bridge and gantry cranes*.

ISO 8686 consists of the following parts, under the general title *Cranes — Design principles for loads and load combinations*:

- Part 1: *General*
- Part 2: *Mobile cranes*
- Part 4: *Jib cranes*
- Part 5: *Overhead travelling and portal bridge cranes*

The design principles for loads and load combinations of tower cranes will form the subject of ISO 8686-3.

© ISO 1992

All rights reserved. No part of this publication may be reproduced or utilized in any form or by any means, electronic or mechanical, including photocopying and microfilm, without permission in writing from the publisher.

International Organization for Standardization
Case postale 56 • CH-1211 Genève 20 • Switzerland

Printed in Switzerland

Cranes — Design principles for loads and load combinations —

Part 5: Overhead travelling and portal bridge cranes

iTeh STANDARD PREVIEW (standards.iteh.ai)

1 Scope

This part of ISO 8686 establishes the application of ISO 8686-1 to overhead travelling and portal bridge cranes as defined in ISO 4306-1, and gives specific values for the factors to be used.

ISO 8306 : 1985, *Cranes — Overhead travelling cranes and portal bridge cranes — Tolerances for cranes and tracks.*

ISO 8686-1 : 1989, *Cranes — Design principles for loads and load combinations — Part 1: General.*

2 Normative references

The following standards contain provisions which, through reference in this text, constitute provisions of this part of ISO 8686. At the time of publication, the editions indicated were valid. All standards are subject to revision, and parties to agreements based on this part of ISO 8686 are encouraged to investigate the possibility of applying the most recent editions of the standards indicated below. Members of IEC and ISO maintain registers of currently valid International Standards.

ISO 4302 : 1981, *Cranes — Wind load assessment.*

ISO 4306-1 : 1990, *Cranes — Vocabulary — Part 1: General.*

ISO 4310 : 1981, *Cranes — Test code and procedures.*

3 Definitions

For the purposes of this part of ISO 8686, the definitions given in ISO 8686-1 apply.

4 Symbols

The symbols used in this part of ISO 8686 are defined in ISO 8686-1.

5 Application of ϕ factors

5.1 The numerical values for different ϕ factors are given in table 1.

Table 1 — Loads and load combinations

1	2	3			4			5					6									
		Load combinations A			Load combinations B			Load combinations C														
Categories of loads	Loads, f_i	Partial load factors γ_p	A1	A2	A3	A4	Partial load factors γ_p	B1	B2	B3	B4	B5	Partial load factors γ_p	C1	C2	C3	C4	C5	C6	C7	C8	Line No.
Regular (see ISO 8686-1 : 1989, 6.1)	1) Mass of the lifting appliance	1,16	ϕ_1	ϕ_1	1	—	1,1	ϕ_1	ϕ_1	1	—	—	1,05	ϕ_1	1	ϕ_1	1	1	1	1	1	1
	2) Mass of the gross load	1,34	ϕ_2	ϕ_3	1	—	1,28	ϕ_3	ϕ_3	1	—	—	1,22	—	η	—	1	1	1	1	1	2
	3) Masses of lifting appliance and hoist load, travelling on an uneven surface	1,16	—	—	—	ϕ_4	—	1,1	—	—	ϕ_4	ϕ_4	1,05	—	—	—	—	—	—	—	—	3
	4) Masses of lifting appliance and gross load	1,55	—	—	—	ϕ_5	ϕ_5	1,48	ϕ_5	ϕ_5	—	—	1,41	—	—	ϕ_5	—	—	—	—	—	—
Occasional (see ISO 8686-1 : 1989, 6.2)	5) See ISO 8686-1 : 1989, 6.1.5	1,16	1	1	1	1	1,1	1	1	1	1	1	1,05	1	1	1	1	1	1	1	1	6
	1) In-service wind loads						1,16	1	1	1	1	1	1,1	—	—	—	1	—	—	—	—	7
	2) Snow and ice loads						1,34	1	1	1	1	1	1,28	—	—	—	—	—	—	—	—	8
	3) Temperature variations						1,1	1	1	1	1	1	1,05	—	—	—	—	—	—	—	—	9
Exceptional (see ISO 8686-1 : 1989, 6.3)	4) See ISO 8686-1 : 1989, 6.2.2						1,16	—	—	—	—	—	—	—	—	—	—	—	—	—	—	10
	1) Hoisting a grounded load (see ISO 8686-1 : 1989, 6.1.2.2.2)												1,22	ϕ_2	—	—	—	—	—	—	—	11
	2) Out-of-service wind loads												1,22	—	1	—	—	—	—	—	—	12
	3) Test loads												1,22	—	—	ϕ_6	—	—	—	—	—	13
Exceptional (see ISO 8686-1 : 1989, 6.3)	4) Buffer forces												1,41	—	—	—	ϕ_7	—	—	—	—	14
	5) Tilting forces												1,41	—	—	—	—	1	—	—	—	15
	6) Emergency cut-out												1,41	—	—	—	—	—	ϕ_5	—	—	16
	7) Failure of mechanism or components												1,41	—	—	—	—	—	—	—	ϕ_5	17
Exceptional (see ISO 8686-1 : 1989, 6.3)	8) External excitation of the lifting appliance foundation												1,41	—	—	—	—	—	—	—	—	18
	Strength coefficient γ_f					1,48					1,34											19
	Resistance coefficient γ_m						1,1						1,05									20
	Coefficient for high-risk applications γ_n (see ISO 8686-1 : 1989, 7.3.6)																					21

5.2 The ϕ_n factors for dynamic effects which are used for load combinations shown in table 1 are given in table 2.

Table 2 — ϕ_n factors

Table 1 line No.	ϕ_n	Reference to ISO 8686-1: 1989	Values for factors ϕ_n , or values for loads, or relevant International Standards
1	ϕ_1	6.1.1	$\phi_1 = 1 \pm a, a = 0,1$
2	ϕ_2	6.1.2.2	ISO 8686-1: 1989, hoisting classes
	ϕ_3	6.1.2.3	ISO 8686-1
3	ϕ_4	6.1.3.2 and annex D	The value of ϕ_4 shall be estimated as shown in ISO 8686-1: 1989, annex D, if there are steps or gaps between the rails
4 and 5	ϕ_5	6.1.4 and annex E	When using rigid body kinetic models: $\phi_5 = 1,2$ if the acceleration and braking forces are changed with stepless control systems without backlash $\phi_5 = 1,5$ in other control systems where the drive forces are acting on the crane practically free of backlash $\phi_5 = 2$ where considerable backlash exists
6		6.1.5	When a displacement remains within the limiting value specified in ISO 8306, its effect can be neglected in the stress analysis
7		6.2.1.1	ISO 4302
8		6.2.1.2	Regional snow- and ice-load conditions
9		6.2.1.3	Ambient and localized temperature variations
10		6.2.2	ISO 8686-1 : 1989, annex F, may be used for guidance
11	$\hat{\phi}_2$	6.1.2.2.2	ISO 8686-1 : 1989, hoisting classes
12		6.3.1	ISO 4302
13	ϕ_6	6.3.2	ISO 8686-1 and ISO 4310
14	ϕ_7	6.3.3	ISO 8686-1
15		6.3.4	ISO 8686-1
16	ϕ_5	6.3.5	$\phi_5 = 2$
17	ϕ_5	6.3.6	$\phi_5 = 2$
18		6.3.7	ISO 8686-1

6 Hoisting classes

Some examples for the selection of hoisting classes according to ISO 8686-1 : 1989, 6.1.2.1, are given in table 3.

Table 3 — Examples

Type of crane	Hoisting class
Manual cranes	HC ₁
Power station cranes Erection cranes Workshop cranes	HC ₂ /HC ₃
Ship unloaders Stockyard cranes } with lifting beams, hooks or spreaders	HC ₃
Ship unloaders Stockyard cranes } with grabs or magnets	HC ₃ /HC ₄
Ladle cranes Open-hearth furnace charging cranes Ingot charging cranes Soaking pit cranes	HC ₃ /HC ₄
Stripper cranes Forge cranes	HC ₄

The examples given in table 3 represent typical applications, structural designs and hoist control systems. More flexible load bearing systems and more sophisticated speed control systems may allow the selection of a lower hoisting class than indicated in table 3. There may be cases where a higher hoisting class is appropriate.

7 Combination of acceleration effects

In the case of overhead travelling and portal bridge cranes, the load is moved by hoisting (H), travelling (Lt), traversing (Ct) and, possibly, by slewing (Sl) mechanisms. (See figure 1.)

The acceleration effects of these mechanisms acting simultaneously on the crane depend on the control systems and service conditions of the crane and whether a load is hoisted from the ground or a suspended load is hoisted.

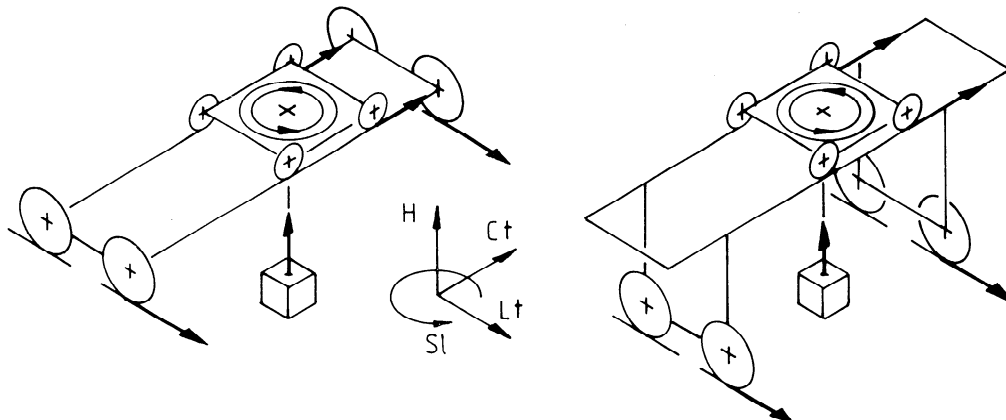

Figure 1

Taking the above into account, the accelerations given in table 4 are assumed to be acting simultaneously.

The gross loads shall be multiplied within the individual load combinations by the following factors:

- load combinations A1 and B1: ϕ_2
- load combinations A2 and B2: ϕ_3
- load combinations A3 and B3: $\left(1 + \phi_5 \times \frac{\Delta F}{mg}\right)$
- load combinations A4 and B4: ϕ_4
- load combination C3: ϕ_6

Drive forces can change significantly in a short time interval. Thus the accelerations shall be calculated

a) for starting the movement,

b) for braking the steady-state movement, and

c) for braking the movement during the starting process, or

d) for accelerating the movement during the braking process (positioning).

Thus the calculated rigid body acceleration forces shall be multiplied by the factor ϕ_5 in accordance with ISO 8686-1 : 1989, 6.1.4.

When considering the positioning effects, only one such effect is combined with other movements.

In load combination C6 or C7, only the dynamic effects of the "emergency cut-out" or of the "failure of mechanism or components" shall be considered without other dynamic effects, assuming the case of starting during steady-state motion.

Table 4 – Combination of acceleration effects

	Hoisting a grounded load Load combinations A1, B1, C1	Hoisting a suspended load Load combinations A2 to A4, B2 to B4, C3
Control by push-button panel or bi-directional control levers		
Control by multi-directional control levers	Power station cranes Erection cranes Workshop cranes 	Power station cranes Erection cranes Workshop cranes Ship unloaders Stockyard cranes Steel mill cranes
	Ship unloaders Stockyard cranes Steel mill cranes 	

iTeh STANDARD PREVIEW
(standards.iteh.ai)

This page intentionally left blank

[ISO 8686-5:1992](#)

<https://standards.iteh.ai/catalog/standards/sist/d21761be-ddd6-4912-9f51-6127acfe772f/iso-8686-5-1992>

iTeh STANDARD PREVIEW
(standards.iteh.ai)

ISO 8686-5:1992

<https://standards.iteh.ai/catalog/standards/sist/d21761be-ddd6-4912-9f51-6127acfe772f/iso-8686-5-1992>

UDC 621.874 : 624.042

Descriptors : lifting equipment, cranes (hoists), travelling cranes, portal bridge cranes, loads (forces), rules of calculation.

Price based on 4 pages
