



Standard Practice for Sampling of Zinc and Zinc Alloys for Optical Emission Spectrometric Analysis¹

This standard is issued under the fixed designation E 634; the number immediately following the designation indicates the year of original adoption or, in the case of revision, the year of last revision. A number in parentheses indicates the year of last reapproval. A superscript epsilon (ϵ) indicates an editorial change since the last revision or reapproval.

1. Scope

1.1 This practice covers the sampling of zinc and zinc alloys to obtain a sample suitable for quantitative optical emission spectrochemical analysis. Included are procedures for obtaining representative samples from molten metal, from fabricated or cast products that can be melted, and from other forms that cannot be melted.

1.2 *This standard does not purport to address all of the safety concerns, if any, associated with its use. It is the responsibility of the user of this standard to establish appropriate safety and health practices and determine the applicability of regulatory limitations prior to use.*

2. Referenced Documents

2.1 ASTM Standards:

E 401 Practice for Bonding Thin Spectrochemical Samples and Standards to a Greater Mass of Material²

3. Summary of Practice

3.1 Molten metal representative of the furnace melt is poured into a mold to produce a chill-cast sample. The sample, which must represent the average composition, is machined to a specified shape to produce an acceptable surface for excitation.

3.2 Fabricated or cast products are remelted and cast into molds or are excited directly without remelting.

4. Significance and Use

4.1 This practice, used in conjunction with an appropriate quantitative optical emission spectrochemical method, is suitable for use in manufacturing control, material or product acceptance, and development and research.

5. Apparatus

5.1 *Ladle*, of steel, designed to hold sufficient molten metal to completely fill the sample mold, with a handle of sufficient length to reach into a furnace, trough, pot, or crucible.

NOTE 1—Pure zinc metal (Special High Grade) is sampled using a

¹ This practice is under the jurisdiction of ASTM Committee E-1 on Analytical Chemistry for Metals, Ores and Related Materials and is the direct responsibility of Subcommittee E01.05 on Zn, Sn, Pb, Cd, Be, and Other Metals.

Current edition approved Oct. 10, 1996. Published December 1996. Originally published as E 634 – 78. Last previous edition E 634 – 78 (1991) ^{ϵ 1}.

² Discontinued; see 1995 Annual Book of ASTM Standards, Vol 03.06.

ceramic or graphite ladle, as the solubility of iron in Special High Grade Zinc is sufficient to cause a measurable contamination.

5.2 *Sample Molds*, designed to produce homogeneous chill-cast specimens having smooth surfaces, free from surface pockets and pores. The specimens shall be representative (in the region to be excited) of the product metal. The samples shall have a spectrochemical response similar to the standards used in preparing the analytical curves. This is ensured by casting standards and specimens in the same manner. Also, the specimens shall have a repeatability of measurement for major elements from excitation-to-excitation with a relative error of no more than 2%. Several types of molds have been found acceptable.

5.2.1 *Type A, Pin Mold* (Fig. 1)—This mold produces two diagonally cast pins with sprues at the top of the specimens. The mold dimensions are such as to produce pins approximately 100 mm (3.9 in.) in length by 11 mm (0.4 in.) in diameter. The mold is made of steel or cast iron and weighs approximately 4.5 to 5.5 kg (10 to 12 lb). Pin specimens have been found to be very homogeneous. If properly prepared, these specimens provide very reliable results with only one burn. However, pin specimens must be reshaped for each additional burn.

5.2.2 *Type B, Book Mold* (Fig. 2)—This mold produces a vertically cast disk with a sprue on the edge of the specimen. The mold dimensions are such as to produce a disk of approximately 64 mm (2.5 in.) in diameter by 6 to 8 mm (0.2 to 0.3 in.) in thickness. A circular central recess, 15 to 25 mm (0.6 to 1.0 in.) in diameter, on one side of the specimen facilitates machining of that side in preparation for excitation. It also promotes more uniform freezing of the raised peripheral area. The mold is made of steel or cast iron and weighs approximately 2 to 3 kg (4 to 7 lb). This mold works well for high purity zinc grades, but with alloys may cause segregation due to solidification phenomena. Specimens should be excited only in the areas indicated in Fig. 3, and it may be necessary to make several burns and report an average. The user is strongly cautioned to thoroughly investigate specimen homogeneity for each alloy system to be analyzed.

5.2.3 *Type C, Center Pour Mold* (Fig. 4)—This mold produces a horizontally cast disk with a sprue over the center on the back side. The mold dimensions are such as to produce a disk approximately 64 mm (2.5 in.) in diameter by 8 mm (0.3 in.) in thickness. A circular central recess, 10 to 20 mm (0.4 to

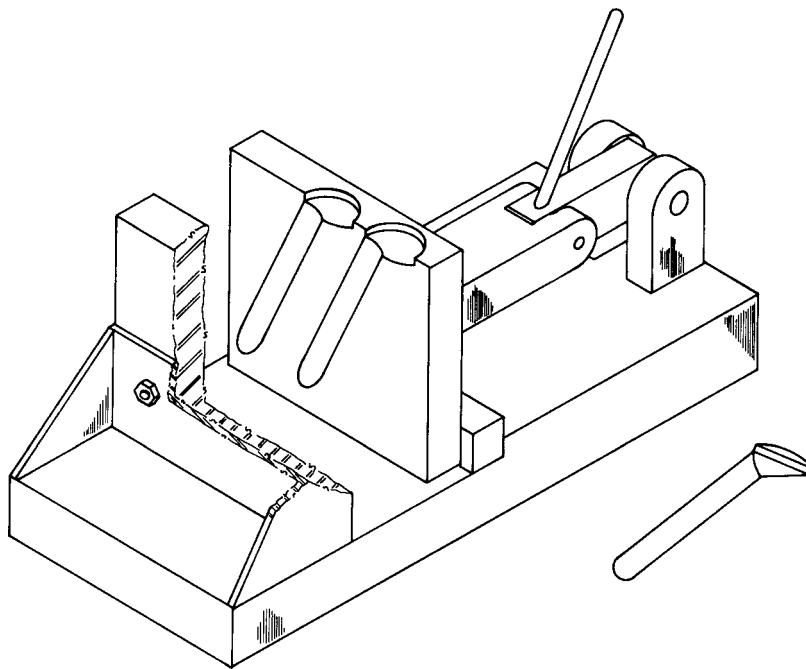

FIG. 1 Type A Mold and Specimen

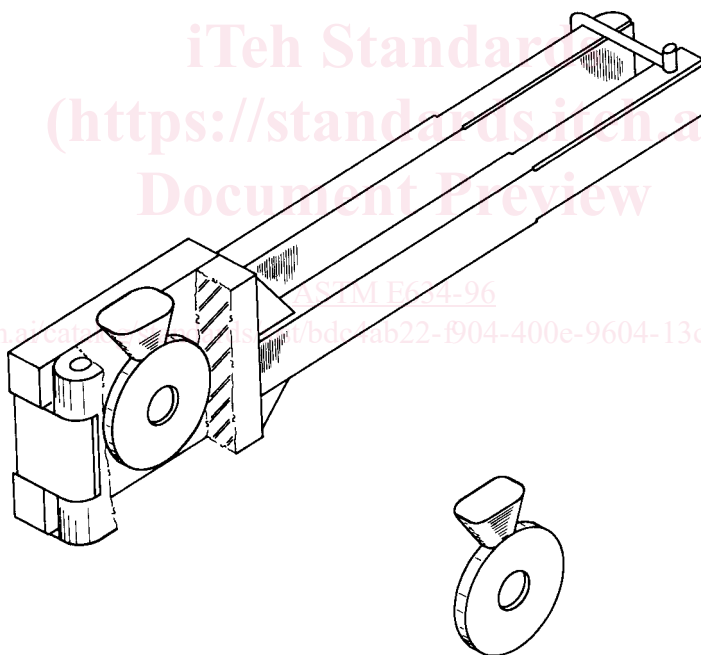

FIG. 2 Type B Mold and Specimen

0.8 in.) in diameter, on one side of the specimen facilitates machining of that side in preparation for excitation. It also promotes more uniform freezing of the raised peripheral area, but the corresponding raised portion of the mold shall not be so large as to restrict the throat for the sprue. A slight taper, 1 to 2 deg, on the hinged portion of the mold facilitates opening when a specimen has been cast. The mold is made of steel or cast iron and weighs approximately 3.5 to 4.5 kg (8 to 10 lb). The advantage of this mold is that the specimen obtained may be excited around the entire annular area. However, as with the

vertically cast disk specimens, although not as severe, segregation can be a problem. Therefore, it may be necessary to make several burns and report an average.

5.2.4 *Other Molds*—Molds of different types, materials, and dimensions may be used provided that the uniformity of the specimens obtained is comparable to the uniformity of specimens obtained from Type A, B, or C molds. Further, the specimens shall have a spectrochemical response similar to the standards used for preparing the analytical curves.