

---

# International Standard



# 8723

---

INTERNATIONAL ORGANIZATION FOR STANDARDIZATION • МЕЖДУНАРОДНАЯ ОРГАНИЗАЦИЯ ПО СТАНДАРТИЗАЦИИ • ORGANISATION INTERNATIONALE DE NORMALISATION

---

## **Carbonaceous materials for the production of aluminium — Calcined coke — Determination of oil content — Method by solvent extraction**

*Produits carbonés utilisés pour la production de l'aluminium — Coke calciné — Détermination de la teneur en huile — Méthode par extraction à l'aide d'un solvant*

iteh STANDARD PREVIEW

First edition — 1986-12-15

(standards.iteh.ai)

[ISO 8723:1986](#)

<https://standards.iteh.ai/catalog/standards/sist/9424b371-ce7d-44a0-81c0-c4a55093dc20/iso-8723-1986>

---

UDC 665.777 : 669.713 : 543.722

Ref. No. ISO 8723-1986 (E)

Descriptors : industrial products, coke, tests, determination of content, oils, extraction methods, aluminium, production.

## Foreword

ISO (the International Organization for Standardization) is a worldwide federation of national standards bodies (ISO member bodies). The work of preparing International Standards is normally carried out through ISO technical committees. Each member body interested in a subject for which a technical committee has been established has the right to be represented on that committee. International organizations, governmental and non-governmental, in liaison with ISO, also take part in the work.

Draft International Standards adopted by the technical committees are circulated to the member bodies for approval before their acceptance as International Standards by the ISO Council. They are approved in accordance with ISO procedures requiring at least 75 % approval by the member bodies voting.

International Standard ISO 8723 was prepared by Technical Committee ISO/TC 47, *Chemistry*.

Users should note that all International Standards undergo revision from time to time and that any reference made herein to any other International Standard implies its latest edition, unless otherwise stated.

ITeH STANDARD PREVIEW  
(standards.iteh.ai)

ISO 8723-1986

https://standards.iteh.ai/catalog/standards/sist/186d-44a0-81c0-c4a55093dc20/iso-8723-1986

# Carbonaceous materials for the production of aluminium — Calcined coke — Determination of oil content — Method by solvent extraction

## 0 Introduction

Calcined coke may be treated with different types of oil in order to limit the formation of a dust cloud during loading and transportation. The method specified in this International Standard permits the determination of the loss of mass in calcined coke after elimination of oil adhering to the particles, by extraction with a suitable solvent.

## 1 Scope and field of application

This International Standard specifies a method for the determination, by solvent extraction, of the oil content of calcined coke in the production of aluminium.

## 2 References

ISO 5725, *Precision of test methods — Determination of repeatability and reproducibility by inter-laboratory tests.*

ISO 6375, *Carbonaceous materials for the production of aluminium — Cokes for electrodes — Sampling.*

## 3 Principle

Treatment of a test portion in an extraction apparatus with dichloromethane (methylene chloride) to remove the oil, and determination of oil removed in terms of the loss of mass of the test portion.

NOTE — The small quantities of water which may still be present in the dried test portion are considered to be oil.

## 4 Solvent

Dichloromethane (methylene chloride), of purity at least 99 %, boiling point 39 to 40 °C.

**WARNING** — Dangerous when inhaled. Avoid contact with the skin. Carry out work in a fume cupboard.

NOTE — The methylene chloride used may be recovered by filtration on activated carbon or by distillation. However, the presence of a

yellow colour after distillation indicates the presence of hydrochloric acid and, in this case, the product should be discarded.

## 5 Apparatus

Ordinary laboratory apparatus and

5.1 **Electric oven**, capable of being controlled at  $110 \pm 2$  °C.

5.2 **Extraction apparatus**, as shown in the figure, and comprising the following items:

5.2.1 **Cylindrical glass funnel**, of capacity approximately 1 000 ml, fitted with a glass fritted disk of porosity P 250 (pore diameter between 160 and 250  $\mu\text{m}$  — see ISO 4793) of effective diameter 45 to 50 mm. The fritted disk is fitted with an internal tube to permit evacuation of air.

5.2.2 **Glass extraction crucible**, vacuum-resistant, of inner effective diameter 45 to 50 mm, fitted with a glass fritted disk of porosity P 4 (pore diameter between 1,6 and 4  $\mu\text{m}$  — see ISO 4793).

5.2.3 **Glass adapter**, provided with a 4 mm polytetrafluorethylene (PTFE) stopcock.

5.2.4 **Glass Büchner flask**, of capacity approximately 2 000 ml.

5.3 **Glass jar**, for supporting the crucible (5.2.2) during drying and weighing.

5.4 **PTFE cuffs**, for sealing joints.

5.5 **Vacuum device** (water pump for example).

5.6 **Drying device**, for drying the crucible (5.2.2) and jar (5.3), containing silica gel or activated alumina.

## 6 Sampling and sample

### 6.1 Sampling

Sampling shall be carried out according to the procedure specified in ISO 6375.

### 6.2 Preparation of test sample

Crush in a mortar approximately 200 g of the laboratory sample to pass a nominal 4 mm mesh sieve (see ISO 565). Dry the crushed and sieved product in the electric oven (5.1), maintained at  $110 \pm 2$  °C, for 2 h and then allow to cool in a desiccator for 1 h.

## 7 Procedure

### 7.1 Test portion

Wash the crucible (5.2.2) with the methylene chloride (clause 4), dry for 30 min in the oven (5.1), maintained at  $110 \pm 2$  °C, using the jar (5.3). Allow to cool to ambient temperature in the drying device (5.6), and weigh the crucible with the jar to the nearest 0,001 g.

Introduce into the crucible approximately 100 g of the test sample (6.2) and weigh the crucible with the jar and the test portion to the nearest 0,001 g. The difference between the two weighings represents the mass of the test portion.

### 7.2 Determination

Assemble the extraction apparatus (5.2). Use the PTFE cuffs (5.4) to seal the joints. Close the stopcock and add the methylene chloride (clause 4) to the crucible (5.2.2) through the funnel (5.2.1) to a level 2 cm above the test portion (approximately 100 ml). Wait until all effervescence ceases (approximately 5 min), open the stopcock and turn on the vacuum device (5.5). When the methylene chloride level reaches the stopcock, close the stopcock. Repeat this procedure 10 times with 1 min extraction time before each drainage. Close the stopcock, remove the crucible and wipe off the moisture from the outside of the crucible. Place the crucible with the jar in the oven, maintained at  $110 \pm 2$  °C, and leave for 30 min. Remove the crucible and the jar from the oven, transfer to the drying device and allow them to cool to ambient temperature. Weigh the crucible, its contents and the jar to the nearest 0,001 g.

## 8 Expression of results

### 8.1 Method of calculation

The oil content, expressed as a percentage by mass, is given by the formula

$$\frac{m_1 - m_2}{m_0} \times 100$$

where

$m_0$  is the mass, in grams, of the test portion (7.1);

$m_1$  is the mass, in grams, of the crucible supported by the jar, containing the test portion before extraction;

$m_2$  is the mass, in grams, of the crucible supported by the jar, containing the test portion after extraction and drying.

Carry out at least two determinations and report the mean value.

### 8.2 Precision (see ISO 5725, sub-clause 3.1)

Nine laboratories from nine different countries have carried out the inter-laboratory tests.

$m$ (mean)	: 0,60 % (m/m)
$r$ (repeatability)	: 0,023 % (m/m)
$R$ (reproducibility)	: 0,050 % (m/m)

## 9 Test report

The test report shall include the following particulars:

- an identification of the sample;
- the reference of the method used;
- the results and the method of expression used;
- any unusual features noted during the determination;
- any operations not included in this International Standard or in the International Standards to which reference is made, or regarded as optional.

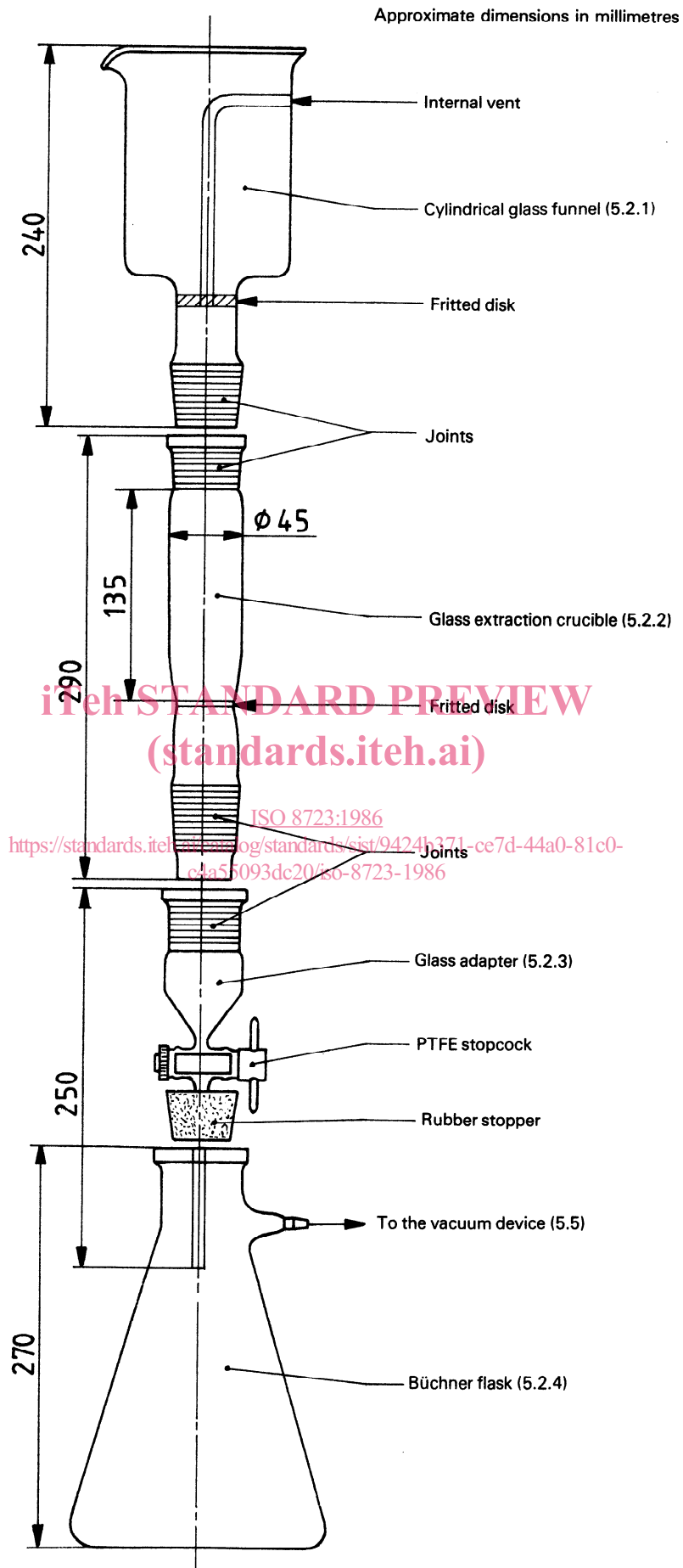

Figure — Extraction apparatus

**iTeh STANDARD PREVIEW**  
**(standards.iteh.ai)**

This page intentionally left blank

[ISO 8723:1986](#)

<https://standards.iteh.ai/catalog/standards/sist/9424b371-ce7d-44a0-81c0-c4a55093dc20/iso-8723-1986>

**iTeh STANDARD PREVIEW**  
**(standards.iteh.ai)**

This page intentionally left blank

[ISO 8723:1986](#)

<https://standards.iteh.ai/catalog/standards/sist/9424b371-ce7d-44a0-81c0-c4a55093dc20/iso-8723-1986>

**iTeh STANDARD PREVIEW**  
**(standards.iteh.ai)**

This page intentionally left blank

[ISO 8723:1986](#)

<https://standards.iteh.ai/catalog/standards/sist/9424b371-ce7d-44a0-81c0-c4a55093dc20/iso-8723-1986>