International Standard



8733

INTERNATIONAL ORGANIZATION FOR STANDARDIZATION • МЕЖДУНАРОДНАЯ ОРГАНИЗАЦИЯ ПО СТАНДАРТИЗАЦИИ • ORGANISATION INTERNATIONALE DE NORMALISATION

Parallel pins with internal thread, unhardened

Goupilles cylindriques à trou taraudé, non trempées

First edition — 1986-10-15

iTeh STANDARD PREVIEW
(standards.iteh.ai)

[ISO 8733:1986](#)

<https://standards.iteh.ai/catalog/standards/sist/c7640913-dba3-4c85-a4ee-196fc521abc7/iso-8733-1986>

UDC 621.886.113

Ref. No. ISO 8733-1986 (E)

Descriptors : fasteners, pins (mechanics), straight pins, specifications, dimensions, designation.

Price based on 3 pages

Foreword

ISO (the International Organization for Standardization) is a worldwide federation of national standards bodies (ISO member bodies). The work of preparing International Standards is normally carried out through ISO technical committees. Each member body interested in a subject for which a technical committee has been established has the right to be represented on that committee. International organizations, governmental and non-governmental, in liaison with ISO, also take part in the work.

Draft International Standards adopted by the technical committees are circulated to the member bodies for approval before their acceptance as International Standards by the ISO Council. They are approved in accordance with ISO procedures requiring at least 75 % approval by the member bodies voting.

International Standard ISO 8733 was prepared by Technical Committee ISO/TC 2, *Fasteners*.

Users should note that all International Standards undergo revision from time to time and that any reference made herein to any other International Standard implies its latest edition, unless otherwise stated.

Parallel pins with internal thread, unhardened

iTeh STANDARD PREVIEW
(standards.iteh.ai)

1 Scope and field of application

This International Standard specifies the characteristics of unhardened parallel pins with internal thread, with metric dimensions and nominal diameters, d_1 , from 6 to 50 mm inclusive.

2 References

ISO 965, *ISO general purpose metric screw threads — Tolerances.*

ISO 2081, *Metallic coatings — Electroplated coatings of zinc on iron or steel.*

ISO 3269, *Fasteners — Acceptance inspection.*

ISO 4520, *Chromate conversion coatings on electroplated zinc and cadmium coatings.*

3 Dimensions

Surface roughness values in micrometres

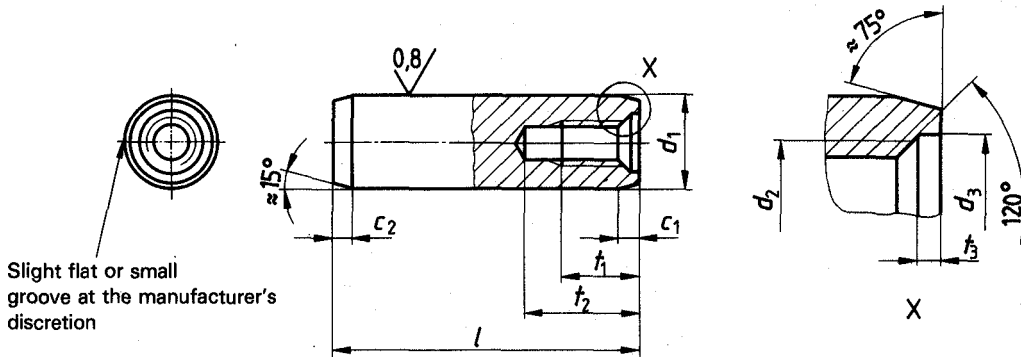

Dimensions in millimetres

d_1	m6 ¹⁾	6	8	10	12	16	20	25	30	40	50
c_1	≈	0,8	1	1,2	1,6	2	2,5	3	4	5	6,3
c_2	≈	1,2	1,6	2	2,5	3	3,5	4	5	6,3	8
d_2		M4	M5	M6	M6	M8	M10	M16	M20	M20	M24
$P^{2)}$		0,7	0,8	1	1	1,25	1,5	2	2,5	2,5	3
d_3		4,3	5,3	6,4	6,4	8,4	10,5	17	21	21	25
t_1		6	8	10	12	16	18	24	30	30	36
t_2	min.	10	12	16	20	25	28	35	40	40	50
t_3		1	1,2	1,2	1,2	1,5	1,5	2	2	2,5	2,5
nom.	$l^{3)}$	min.	max.								
16	15,5	16,5									
18	17,5	18,5									
20	19,5	20,5									
22	21,5	22,5									
24	23,5	24,5									
26	25,5	26,5									
28	27,5	28,5									
30	29,5	30,5	Range								
32	31,5	32,5									
35	34,5	35,5									
40	39,5	40,5	of								
45	44,5	45,5									
50	49,5	50,5									
55	54,25	55,75									
60	59,25	60,75									
65	64,25	65,75									
70	69,25	70,75	commercial								
75	74,25	75,75									
80	79,25	80,75									
85	84,25	85,75									
90	89,25	90,75									
95	94,25	95,75									
100	99,25	100,75	lengths								
120	119,25	120,75									
140	139,25	140,75									
160	159,25	160,75									
180	179,25	180,75									
200	199,25	200,75									

- 1) Other tolerances as agreed between customer and supplier.
- 2) P = thread pitch.
- 3) For nominal lengths above 200 mm, steps of 20 mm.

4 Specifications and reference International Standards

Screw thread	Metric screw thread with tolerance 6H to ISO 965.
Material	St = Free-cutting steel, hardness 125 to 245 HV. Other materials as agreed between customer and supplier.
Surface finish	Plain, i.e. pins to be supplied in natural finish treated with a rust-preventative lubricant, unless otherwise specified by agreement between customer and supplier. Preferred coatings are black oxide, phosphate coating or zinc plating with chromate conversion coating (see ISO 2081 and ISO 4520). Other coatings as agreed between customer and supplier. All tolerances shall apply prior to the application of a plating or coating.
Workmanship	Parts shall be uniform in quality and free of irregularities or detrimental defects. No burrs shall appear on any part of the pin.
Acceptability	The acceptance procedure is covered in ISO 3269.

5 Designation

Example for the designation of an unhardened steel parallel pin with internal thread, nominal diameter $d_1 = 6$ mm and nominal length $l = 30$ mm :

Parallel pin ISO 8733 - 6 × 30 - St

iTeh STANDARD PREVIEW
(standards.iteh.ai)

ISO 8733:1986

<https://standards.iteh.ai/catalog/standards/sist/c7640913-dba3-4c85-a4ee-196fc521abc7/iso-8733-1986>