

INTERNATIONAL STANDARD

**Ferrite cores – Guide on the limits of surface irregularities –
Part 5: Planar-cores**

<https://standards.iteh.ai/catalog/standards/sist/604570-0b10-40d4-b3e4-549b8f0c6b7f/iec-60424-5-2009>



THIS PUBLICATION IS COPYRIGHT PROTECTED

Copyright © 2009 IEC, Geneva, Switzerland

All rights reserved. Unless otherwise specified, no part of this publication may be reproduced or utilized in any form or by any means, electronic or mechanical, including photocopying and microfilm, without permission in writing from either IEC or IEC's member National Committee in the country of the requester.

If you have any questions about IEC copyright or have an enquiry about obtaining additional rights to this publication, please contact the address below or your local IEC member National Committee for further information.

IEC Central Office
3, rue de Varembe
CH-1211 Geneva 20
Switzerland
Email: inmail@iec.ch
Web: www.iec.ch

About the IEC

The International Electrotechnical Commission (IEC) is the leading global organization that prepares and publishes International Standards for all electrical, electronic and related technologies.

About IEC publications

The technical content of IEC publications is kept under constant review by the IEC. Please make sure that you have the latest edition, a corrigenda or an amendment might have been published.

- Catalogue of IEC publications: www.iec.ch/searchpub

The IEC on-line Catalogue enables you to search by a variety of criteria (reference number, text, technical committee,...). It also gives information on projects, withdrawn and replaced publications.

- IEC Just Published: www.iec.ch/online_news/justpub

Stay up to date on all new IEC publications. Just Published details twice a month all new publications released. Available on-line and also by email.

- Electropedia: www.electropedia.org

The world's leading online dictionary of electronic and electrical terms containing more than 20 000 terms and definitions in English and French, with equivalent terms in additional languages. Also known as the International Electrotechnical Vocabulary online.

- Customer Service Centre: www.iec.ch/webstore/custserv

If you wish to give us your feedback on this publication or need further assistance, please visit the Customer Service Centre FAQ or contact us:

Email: csc@iec.ch
Tel.: +41 22 919 02 11
Fax: +41 22 919 03 00

INTERNATIONAL STANDARD

**Ferrite cores – Guide on the limits of surface irregularities –
Part 5: Planar-cores**

INTERNATIONAL
ELECTROTECHNICAL
COMMISSION

PRICE CODE

N

ICS 29.100.10

ISBN 978-2-88910-190-0

CONTENTS

FOREWORD.....	3
1 Scope.....	5
2 Normative references	5
3 Limits of surface irregularities.....	6
3.1 Chips and ragged edges.....	6
3.1.1 Chips and ragged edges on the mating surfaces (see Figures 1, 2 and 3).....	6
3.1.2 Chips and ragged edges on other surfaces.....	7
3.2 Cracks.....	10
3.3 Flash.....	10
3.4 Pull-out	10
Figure 1 – Chip location for planar EL-core.....	6
Figure 2 – Chip location for low profile E-core.....	6
Figure 3 – Chip location for low profile ER-core	6
Figure 4 – Cracks and pull-out location for planar EL-core.....	10
Figure 5 – Cracks and pull-out location for low profile E-core.....	11
Figure 6 – Cracks and pull-out location for low profile ER-core	11
Figure 7 – Reference dimensions for EL-core	11
Figure 8 – Reference dimensions for E-core.....	12
Figure 9 – Reference dimensions for ER-core.....	13
Table 1 – Allowable areas of chips in mm ² for planar EL-core.....	7
Table 2 – Allowable areas of chips in mm ² for low profile E-core	8
Table 3 – Allowable areas of chips in mm ² for low profile ER-core.....	8
Table 4 – Area and length reference for visual inspection	9
Table 5 – Limits of cracks for planar EL-core	12
Table 6 – Limits of cracks for low profile E-core.....	13
Table 7 – Limits of cracks for low profile ER-core	14

INTERNATIONAL ELECTROTECHNICAL COMMISSION

FERRITE CORES – GUIDE ON THE LIMITS OF SURFACE IRREGULARITIES –

Part 5: Planar-cores

FOREWORD

- 1) The International Electrotechnical Commission (IEC) is a worldwide organization for standardization comprising all national electrotechnical committees (IEC National Committees). The object of the IEC is to promote international co-operation on all questions concerning standardization in the electrical and electronic fields. To this end and in addition to other activities, IEC publishes International Standards, Technical Specifications, Technical Reports, Publicly Available Specifications (PAS) and Guides (hereafter referred to as "IEC Publication(s)"). Their preparation is entrusted to technical committees; any IEC National Committee interested in the subject dealt with may participate in this preparatory work. International, governmental and non-governmental organizations liaising with the IEC also participate in this preparation. IEC collaborates closely with the International Organization for Standardization (ISO) in accordance with conditions determined by agreement between the two organizations.
- 2) The formal decisions or agreements of IEC on technical matters express, as nearly as possible, an international consensus of opinion on the relevant subjects since each technical committee has representation from all interested IEC National Committees.
- 3) IEC Publications have the form of recommendations for international use and are accepted by IEC National Committees in that sense. While all reasonable efforts are made to ensure that the technical content of IEC Publications is accurate, IEC cannot be held responsible for the way in which they are used or for any misinterpretation by any end user.
- 4) In order to promote international uniformity, IEC National Committees undertake to apply IEC Publications transparently to the maximum extent possible in their national and regional publications. Any divergence between any IEC Publication and the corresponding national or regional publication shall be clearly indicated in the latter.
- 5) IEC provides no marking procedure to indicate its approval and cannot be rendered responsible for any equipment declared to be in conformity with an IEC Publication.
- 6) All users should ensure that they have the latest edition of this publication.
- 7) No liability shall attach to IEC or its directors, employees, servants or agents including individual experts and members of its technical committees and IEC National Committees for any personal injury, property damage or other damage of any nature whatsoever, whether direct or indirect, or for costs (including legal fees) and expenses arising out of the publication, use of, or reliance upon, this IEC Publication or any other IEC Publications.
- 8) Attention is drawn to the Normative references cited in this publication. Use of the referenced publications is indispensable for the correct application of this publication.
- 9) Attention is drawn to the possibility that some of the elements of this IEC Publication may be the subject of patent rights. IEC shall not be held responsible for identifying any or all such patent rights.

International Standard IEC 60424-5 has been prepared by IEC technical committee 51: Magnetic components and ferrite materials.

The text of this standard is based on the following documents:

FDIS	Report on voting
51/947/FDIS	51/950/RVD

Full information on the voting for the approval of this standard can be found in the report on voting indicated in the above table.

This publication has been drafted in accordance with the ISO/IEC Directives, Part 2.

A list of all parts of the IEC 60424 series, under the general title *Ferrite cores – Guide on the limits of surface irregularities*, can be found on the IEC website.

The committee has decided that the contents of this publication will remain unchanged until the maintenance result date indicated on the IEC web site under "<http://webstore.iec.ch>" in the data related to the specific publication. At this date, the publication will be

- reconfirmed,
- withdrawn,
- replaced by a revised edition, or
- amended.

A bilingual version of this publication may be issued at a later date.



FERRITE CORES – GUIDE ON THE LIMITS OF SURFACE IRREGULARITIES –

Part 5: Planar-cores

1 Scope

This part of IEC 60424 gives guidance on allowable limits of surface irregularities applicable to planar-cores in accordance with the relevant generic specification defined in IEC 60424-1.

The relations between the main dimensions of planar E-, ER- and EL-cores differ from those of standard cores. For example, the width of planar cores is larger while the total height is much smaller. Also the thickness of the legs is in most cases smaller than compared to standard cores. Therefore the concept of fixed reference dimensions to determine the length of crack limits yield crack lengths which are not acceptable for this type of core. This part of IEC 60424 follows another concept which relates the crack length to dimensions of the surface on which the crack occurs.

Also the concept to determine the maximum area of chips based on the total mating surface fails in the case of planar cores. The outer legs of planar cores are much thinner than those of standard cores which makes overlapping and gluing much more difficult. A single chip of maximum size on the outer leg may risk the functionality of the core set. Therefore this standard uses as a reference the mating surface on which the chip occurs.

Windings of planar cores are often PCB's which are glued to the inner surfaces of the planar core. For this reason the inner surfaces of the planar cores need to have a better quality than the inner surfaces of standard cores. This was taken into account by reducing the maximum allowable area of pull outs in the inner surfaces.

This standard is considered as a sectional specification useful in the negotiation between ferrite core manufacturers and users about surface irregularities.

2 Normative references

The following referenced documents are indispensable for the application of this document. For dated references, only the edition cited applies. For undated references, the latest edition of the referenced document (including any amendments) applies.

IEC 60424-1, *Ferrite cores – Guide on the limits of surface irregularities – Part 1: General specification*

IEC 62317-9, *Ferrite cores – Dimensions – Part 9: Planar-cores*

3 Limits of surface irregularities

3.1 Chips and ragged edges

3.1.1 Chips and ragged edges on the mating surfaces (see Figures 1, 2 and 3)

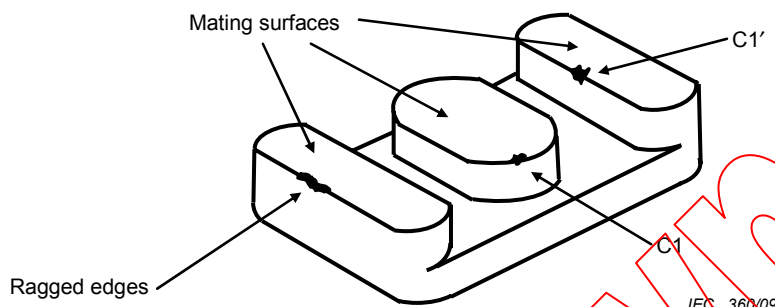

Figure 1 – Chip location for planar EL-core

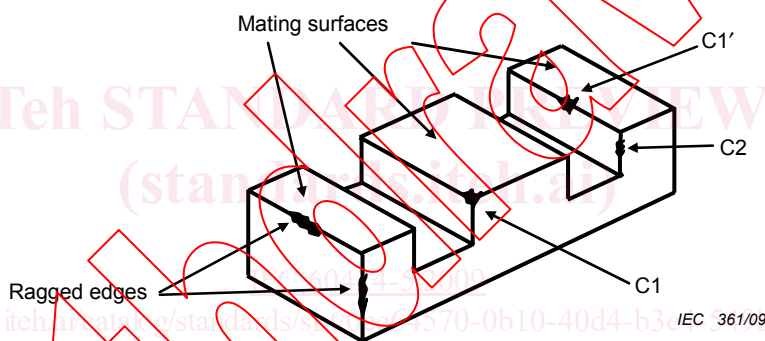

Figure 2 – Chip location for low profile E-core

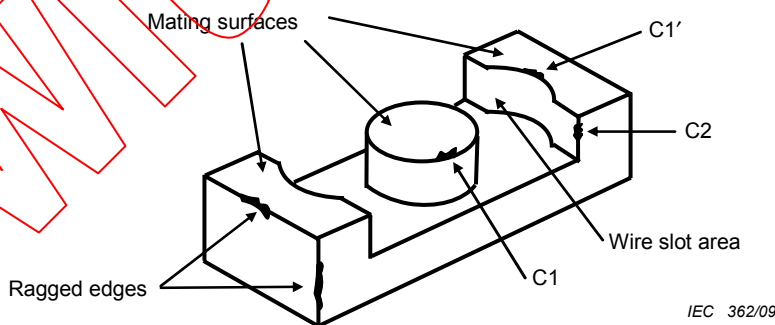

Figure 3 – Chip location for low profile ER-core

Areas of the chips located on the mating surfaces (C1 and C1' irregularities in Figures 1, 2 and 3) shall not exceed the following limits:

- the cumulative area of the chips shall be less than 4 % of the relevant mating surface. The mating surface of each outer leg and centre post is considered separately; the allowable areas are rounded to the figures in Table 4 (Area and length reference for visual inspection) and the minimum allowable area is taken as 0,5 mm² to be distinguishable to the naked eye;

- the total area of all chips on all mating surfaces shall not exceed the value given for “overall chipping on the mating surface” in Tables 1, 2 or 3;
- the total length of the ragged edges shall be less than 25 % of the perimeter of the relevant mating surface.

3.1.2 Chips and ragged edges on other surfaces

- the allowable chipping areas are doubled as compared to the limits for the whole mating surfaces (see Table 1 for planar EL-cores, Table 2 for low profile E-cores, Table 3 for low profile ER-cores);
- the total length of the ragged edges shall be less than 25 % of the perimeter of the smaller adjoining surface;
- chips and ragged edges are not acceptable on the ridge of the clamping recess area;
- chips and ragged edges are not acceptable on the inner edges of wire slot area. (C2 irregularity in Figures 2 and 3)

The core sizes given in Tables 1, 2 and 3 correspond to the cores defined in IEC 62317-9, and area and length reference for visual inspection are given in Table 4.

Table 1 – Allowable areas of chips in mm² for planar EL-core

Core size	Chipping on mating surface of one outer leg	Chipping on mating surface of centre post	Overall chipping on mating surface	Other surfaces
EL 11 × 2,0	0,5	0,5	1,5	3,0
EL 11 × 3,0	0,5	0,5	1,5	3,0
EL 13 × 2,2	0,5	1,0	2,0	4,0
EL 13 × 3,2	0,5	1,0	2,0	4,0
EL 15,5 × 2,9	0,5	1,0	2,0	4,0
EL 15,5 × 4,4	0,5	1,0	2,0	4,0
EL 18 × 3,7	1,0	2,0	4,0	8,0
EL 18 × 5,7	1,0	2,0	4,0	8,0
EL 20 × 3,8	1,0	2,0	4,0	8,0
EL 20 × 5,8	1,0	2,0	4,0	8,0
EL 22 × 4,0	1,5	2,5	5,5	11,0
EL 22 × 6,0	1,5	2,5	5,5	11,0
EL 25 × 4,3	1,5	3,5	6,5	13,0
EL 25 × 6,3	1,5	3,5	6,5	13,0

Table 2 – Allowable areas of chips in mm² for low profile E-core

Core size	Chipping on mating surface of one outer leg	Chipping on mating surface of centre post	Overall chipping on mating surface	Other surfaces
E 14 × 3,5 × 5	0,5	0,5	1,5	3,0
E 18 × 4 × 10	1,0	1,5	3,5	7,0
E 22 × 6 × 16	1,5	3,0	6,0	12,0
E 32 × 6 × 20	2,5	5,0	10,0	20,0
E 38 × 8 × 25	3,5	8,0	15,0	30,0
E 43 × 10 × 28	4,5	9,0	18,0	36,0
E 58 × 11 × 38	6,0	12,5	24,5	49,0
E 64 × 10 × 50	10,0	20,0	40,0	80,0
E 102 × 20 × 38	12,5	20,0	45,0	90,0

Table 3 – Allowable areas of chips in mm² for low profile ER-core

Core size	Chipping on mating surface of one outer leg	Chipping on mating surface of centre post	Overall chipping on mating surface	Other surfaces
ER 9,5 × 2,5 × 5	0,5	0,5	1,5	3,0
ER 11 × 2,5 × 6	0,5	0,5	1,5	3,0
ER 13 × 3 × 9	0,5	1,0	2,0	4,0
ER 14,5 × 3 × 7	0,5	1,0	2,0	4,0
ER 18 × 3 × 10	0,5	1,0	2,0	4,0
ER 20 × 6 × 14	1,5	2,0	5,0	10,0
ER 23 × 3,6 × 13	1,0	2,0	4,0	8,0
ER 23 × 5 × 13	1,0	2,0	4,0	8,0
ER 25 × 6 × 15	1,5	3,0	6,0	12,0
ER 30 × 8 × 20	2,5	4,0	9,0	18,0
ER 32 × 5 × 21	2,0	4,0	8,0	16,0
ER 32 × 6 × 25	2,5	5,0	10,0	20,0
ER 35 × 10 × 26	3,5	7,0	14,0	28,0
ER 40 × 10 × 28	4,0	7,0	15,0	30,0