

Revised

INTERNATIONAL STANDARD



1161

INTERNATIONAL ORGANIZATION FOR STANDARDIZATION • МЕЖДУНАРОДНАЯ ОРГАНИЗАЦИЯ ПО СТАНДАРТИЗАЦИИ • ORGANISATION INTERNATIONALE DE NORMALISATION

Series 1 freight containers — Corner fittings — Specification

Conteneurs de la série 1 — Pièces de coin — Spécifications

First edition — 1976-07-15

UDC 621.869.88

Ref. No. ISO 1161-1976 (E)

Descriptors: freight containers, corner fittings, specifications, dimensions, dimensional tolerances, mechanical strength, stacking, hoisting, loads (forces), ratings, marking.

Price based on 13 pages

FOREWORD

ISO (the International Organization for Standardization) is a worldwide federation of national standards institutes (ISO Member Bodies). The work of developing International Standards is carried out through ISO Technical Committees. Every Member Body interested in a subject for which a Technical Committee has been set up has the right to be represented on that Committee. International organizations, governmental and non-governmental, in liaison with ISO, also take part in the work.

Draft International Standards adopted by the Technical Committees are circulated to the Member Bodies for approval before their acceptance as International Standards by the ISO Council.

International Standard ISO 1161 was drawn up by Technical Committee ISO/TC 104, *Freight containers*, and was circulated to the Member Bodies in October 1975.

It has been approved by the Member Bodies of the following countries :

| | | |
|----------------|-------------|-----------------------|
| Australia | Germany | Poland |
| Austria | Hungary | Romania |
| Belgium | India | South Africa, Rep. of |
| Brazil | Ireland | Spain |
| Bulgaria | Israel | Sweden |
| Canada | Italy | Switzerland |
| Cuba | Japan | Turkey |
| Czechoslovakia | Mexico | United Kingdom |
| Denmark | Netherlands | U.S.A. |
| Finland | New Zealand | U.S.S.R. |
| France | Norway | Yugoslavia |

No Member Body expressed disapproval of the document.

This International Standards cancels and replaces ISO Recommendation R 1161-1970, of which it constitutes a technical revision.

Series 1 freight containers – Corner fittings – Specification

0 INTRODUCTION

This International Standard on corner fittings represents the efforts of technical and operational personnel drawn from all phases of the transportation industry. The figures show the fittings for the top and bottom corners of series 1 freight containers which will provide compatibility in interchange between transportation modes. Care has been taken to limit consideration only to those details vital to this function.

The location, size and configuration of corner fitting apertures are specified. The faces of the corner fittings having apertures for the engagement of handling and securing devices have prescribed thickness and tolerances as shown in figures 1, 2, 3 and 4. The thickness of the blank walls is not prescribed since they are not involved in the engagement of the handling and securing devices, as long as their inner surfaces do not protrude into the corner fitting cavity reserved for the engaging devices; however, typical overall dimensions of top and bottom corner fitting are given in annex A by way of example. **These overall dimensions are not mandatory.**

The purpose of this International Standard is to define some details of design vital to container interchange in automatic, semi-automatic and conventional systems.

The strength and testing requirements specified in this International Standard do not take any account of the stresses which may result from the practice of end-to-end coupling of containers.

Typical examples of twistlocks which may be fitted on handling devices are given in annex B.

NOTE – The requirements of this International Standard do not preclude the provision of additional facilities for lifting either from the top or at the base of the freight container.

1 SCOPE AND FIELD OF APPLICATION

This International Standard establishes the basic dimensions and the functional and strength requirements of corner fittings for series 1 freight containers, i.e. containers which *inter alia* conform to ISO 668 with the exception of air mode containers (see ISO 1496/VII).

2 REFERENCES

ISO 668, *Freight containers – External dimensions and ratings.*

ISO 1496/I, *Series 1 freight containers – Specification and testing – Part I : General cargo containers.*

ISO 1496/III, *Series 1 freight containers – Specification and testing – Part III : Tank containers for liquids and gases.*

ISO 1496/VII, *Series 1 freight containers – Specification and testing – Part VII : Air mode containers.*

3 DIMENSIONAL REQUIREMENTS

3.1 General

3.1.1 The dimensions and tolerances of the corner fittings shall conform to figures 1, 2, 3 and 4.

For containers 1AA, 1A, 1BB, 1B, 1CC, 1C and 1D, each container shall have two right-hand top corner fittings (on the right as the observer faces either end of the container) and two left-hand top corner fittings which are the mirror image of the right-hand fittings (see figure 5). Containers 1E and 1F shall have top corner fittings in the same configuration.

The bottom corner fittings shall have a similar configuration except in respect of the end aperture. For containers 1E and 1F the bottom corner fittings are optional. The corner fittings shown in figures 1 to 4 illustrate right-hand (RH) top and bottom fittings only; for the left-hand (LH) corner fittings the dimensions are simply transposed.

3.1.2 Typical external dimensions which may be used to develop a box-shaped fitting are given as an example in annex A.

3.2 Detailed dimensional and manufacturing requirements

3.2.1 Sharp corners shall be removed as far as practicable.

3.2.2 Where dimensions are not specified for inner and outer edges of apertures, these edges shall be given a radius of $3 \begin{smallmatrix} 0 \\ -1,5 \end{smallmatrix}$ mm ($1/8 \begin{smallmatrix} 0 \\ -1/16 \end{smallmatrix}$ in).

3.2.3 At the junction of the two 6 mm (1/4 in) outside edge radii with the 14,5 mm (9/16 in) edge radius the corner should be rounded by blending the radiused edges, removing minimum amounts of material from the flat outer faces and walls.

3.2.4 Where a corner fitting has an optional inner side wall and is made to the minimum dimension of 149 mm (5 7/8 in) the junction of the mandatory horizontal face to the optional inner side wall may be provided with a radius not exceeding 5,5 mm (7/32 in).

If a greater radius is required, the 149 mm dimension must be increased accordingly.

3.3 Location

After installation of the corner fittings, the perpendicularity or trueness of the containers shall be determined by measuring the difference between dimensions D_1 and D_2 , between D_3 and D_4 and between D_5 and D_6 shown in figure 5. The maximum allowable differences, expressed as K_1 max. and K_2 max. in the table, shall not be exceeded.

4 STRENGTH REQUIREMENTS

The corner fittings shall be designed and constructed in such a manner and of such materials as to enable them to pass the operating and testing requirements laid down in ISO 1496/1.

5 DESIGN REQUIREMENTS

5.1 Loads

The following containers' design loads and criteria were used in establishing the dimensional design of corner fitting specified in this International Standard.

Corner fittings for series 1 freight containers shall be capable of withstanding the loads calculated in accordance with the requirements of ISO 1496/1 for 1A and 1AA containers. The calculated design loads are listed in the following sub-clauses.

| 5.1.1 Stacking | Design loads |
|--|-----------------------------------|
| Top corner fitting (superimposed load offset 25,4 mm (1 in) laterally and 38 mm (1 1/2 in) longitudinally) | 680 kN (69 340 kgf or 68 tonf) |
| Bottom corner fitting (resting on flat support) | 805 kN (82 100 kgf or 81 tonf) |
| Bottom corner fitting (of No. 5 container offset 25,4 mm (1 in) laterally and 38 mm (1 1/2 in) longitudinally with respect to No. 6 container) | 680 kN (69 340 kgf or 68 tonf) |

| 5.1.2 Lifting | Design loads |
|---|-----------------------------------|
| Top corner fitting (twistlock (see also clause 6), hook or shackle) | 150 kN (15 200 kgf or 15 tonf) |

Bottom corner fitting : sling at 30° to horizontal 300 kN
(30 400 kgf or 30 tonf)

NOTES

Bottom corner fitting lifting

1 The line of action of the sling is assumed to be parallel to and not more than 38 mm (1 1/2 in) from the outer face of the corner fitting.

2 The load values quoted are for slings at the angles stated, but it is recognized that slings may be used at any angle between the angle stated and the vertical.

| 5.1.3 Longitudinal restraint | Design loads |
|--|---|
| Bottom corner fittings (Two fittings carrying load) | 300 kN (30 400 kgf or 30 tonf each) (2 g × 1 R) |

5.1.4 Lashing and securing

Loads imparted at front and side holes of both top and bottom corner fittings due to lashing and securing are assumed not to exceed 300 kN (30 400 kgf or 30 tonf) vertically and 150 kN (15 200 kgf or 15 tonf) horizontally, both forces being in a plane parallel to the face of the corner fitting, at a distance of not more than 38 mm (1 1/2 in) from the face.

The maximum resultant load due to combined vertical and horizontal lashing or securing loads shall not exceed the values indicated by the envelope of the diagram given in figure 6.

5.1.5 Misgather (localized loading of bottom corner fittings caused by lowering of container onto locating fittings which are not gathered into the hole)

Bottom corner fittings shall be capable of withstanding a load of 150 kN (15 200 kgf or 15 tonf) applied normally to the contact area of 25 mm (1 in) × 6 mm (1/4 in) on the bottom face (see figure 7).

5.2 Compulsory features

Compulsory walls or faces in the corner fittings are :

Top corner fittings :

- the top face
- the side wall
- the end wall

Bottom corner fittings :

- the bottom face
- the side wall
- the end wall

6 MINIMUM BEARING AREA — TOP CORNER FITTING

It is assumed that lifting devices which use only the top apertures of the four top corner fittings will have a minimum total bearing area on the horizontal part of the inner top surfaces of the top corner fittings of 800 mm² (1.24 in²), for each of the top corner fittings.

Examples of twistlock lifting devices are given in annex B.

7 CORNER FITTING MARKING (where provided)

Markings on upper and lower corner fittings shall be located at positions where they are clearly visible after assembly of the fittings to freight containers, and where they will not interfere with the satisfactory functioning of handling, locating and securing devices used in conjunction with the corner fittings.

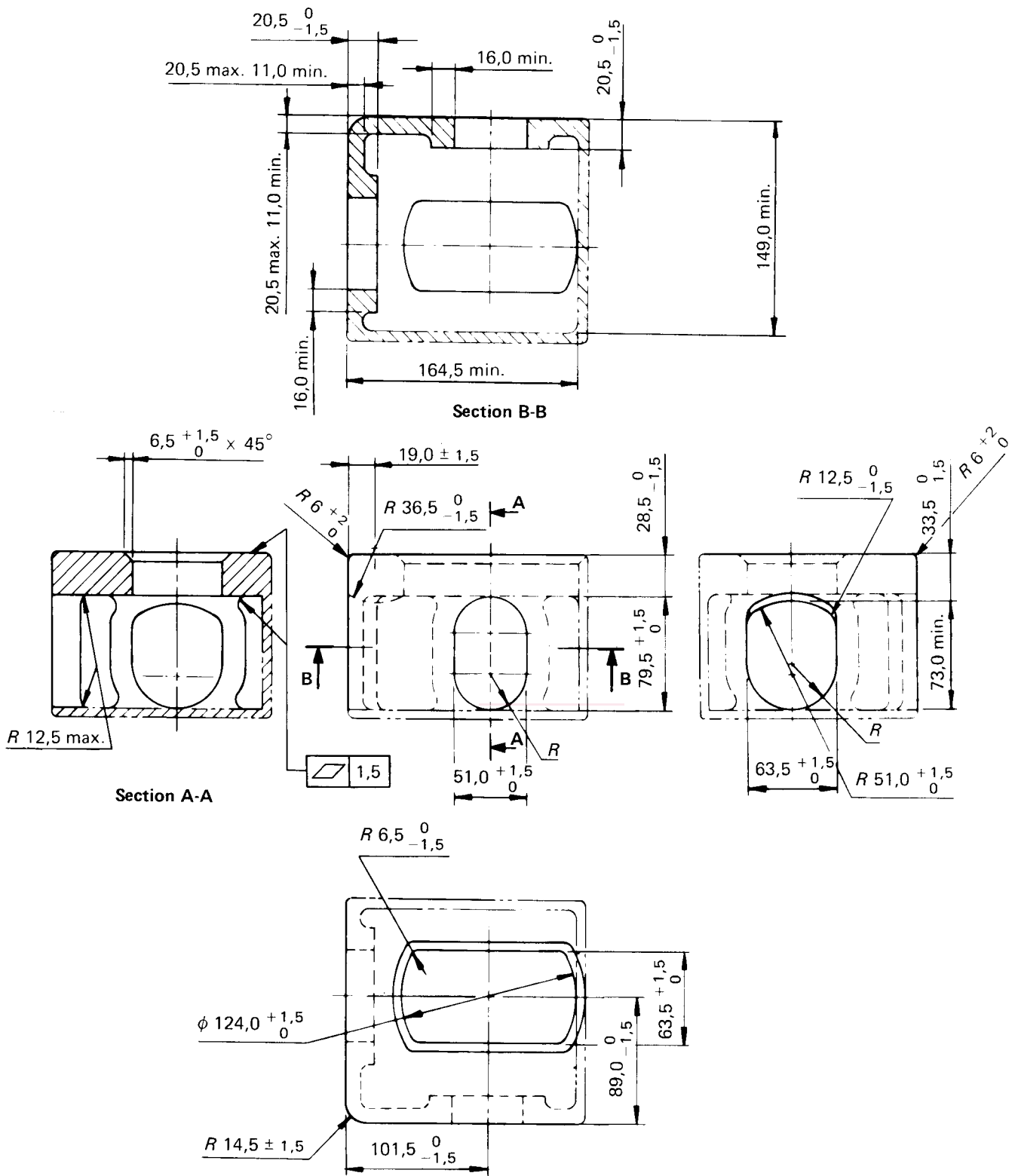

NOTES

- 1 Solid and broken lines (— and - -) show surfaces and contours which must be physically duplicated in the fitting.
- 2 Phantom lines (-----) show optional walls, which may be used to develop a box-shaped fitting.

FIGURE 1 — Top corner fitting — Dimensions in millimetres
(see clause 3)

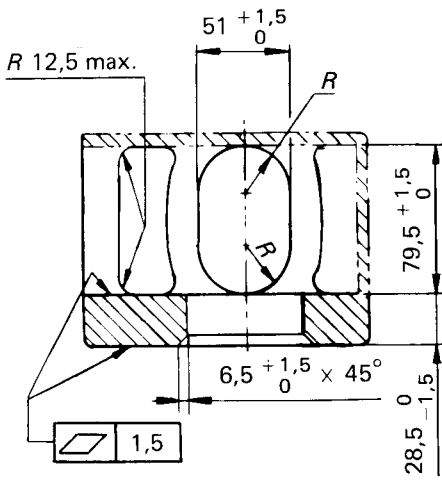
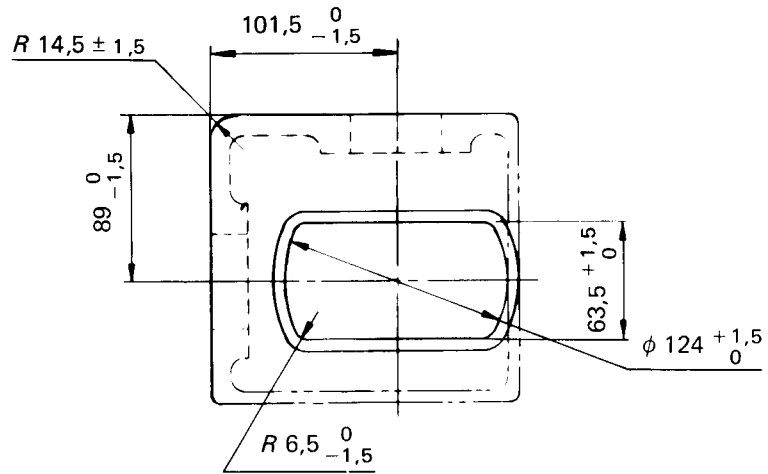

Section A-A

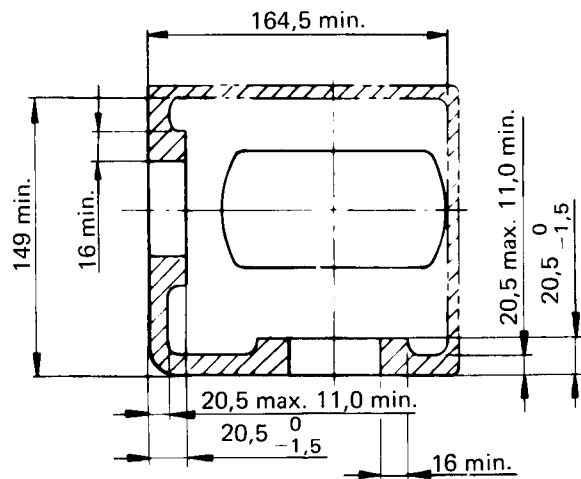
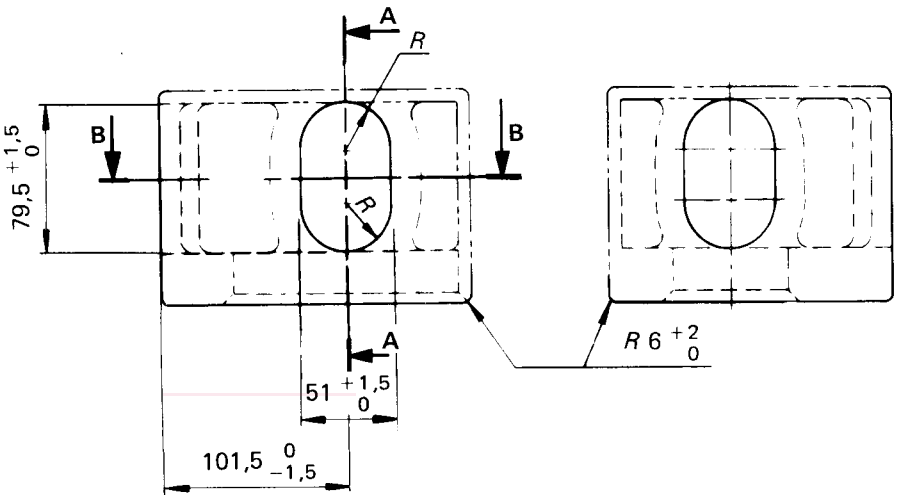

Section B-B

NOTES

- 1 Solid and broken lines (— and - -) show surfaces and contours which must be physically duplicated in the fitting.
- 2 Phantom lines (- - - -) show optional walls, which may be used to develop a box-shaped fitting.

FIGURE 3 – Bottom corner fitting – Dimensions in millimetres
(see clause 3)

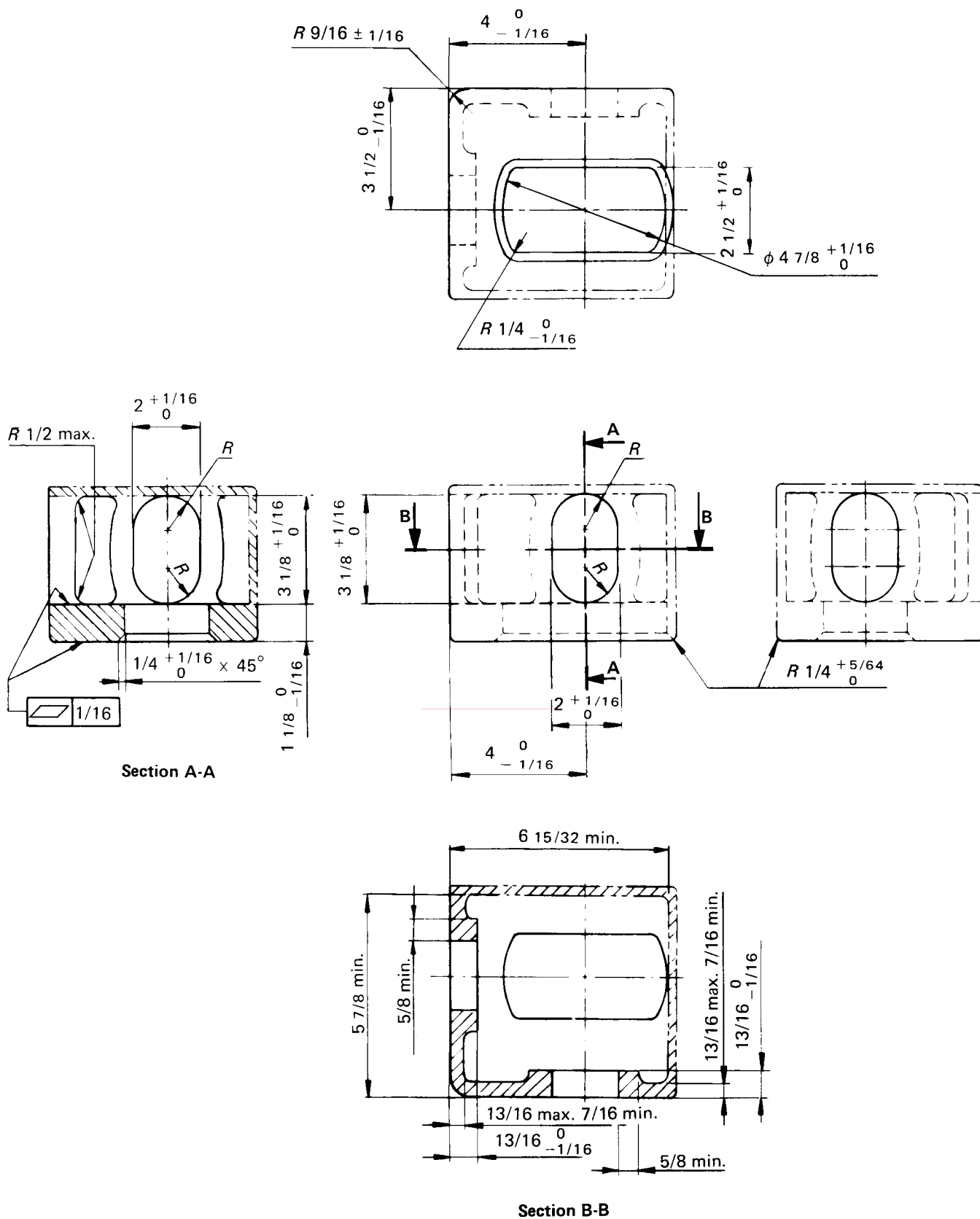

NOTES

- 1 Solid and broken lines (— and - -) show surfaces and contours which must be physically duplicated in the fitting.
- 2 Phantom lines (---) show optional walls, which may be used to develop a box-shaped fitting.

FIGURE 4 – Bottom corner fitting – Dimensions in inches
(see clause 3)

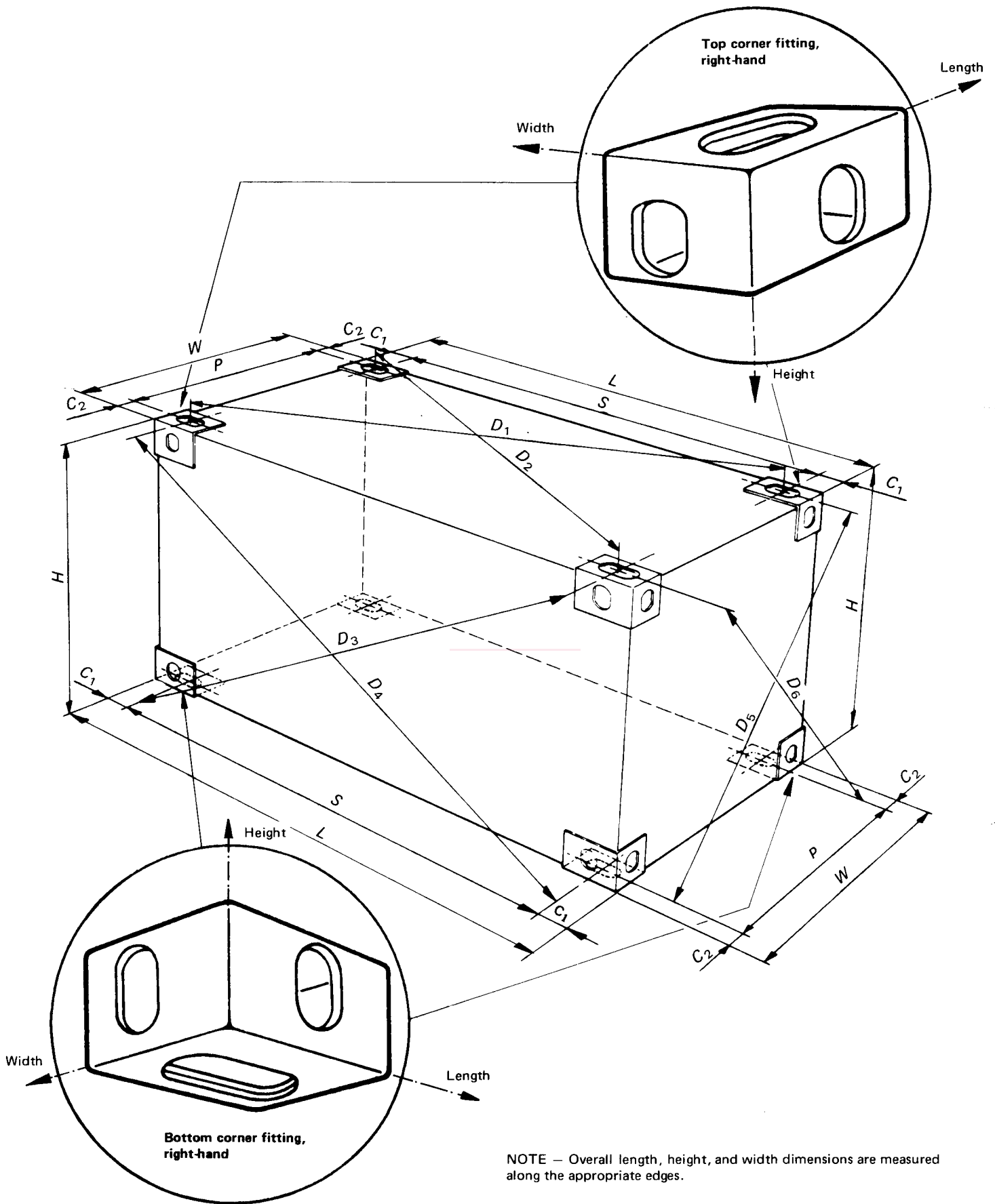

NOTE — Overall length, height, and width dimensions are measured along the appropriate edges.

FIGURE 5 — Assembled corner fittings — Diagonal tolerances (see table)