International Standard



8749

INTERNATIONAL ORGANIZATION FOR STANDARDIZATION • МЕЖДУНАРОДНАЯ ОРГАНИЗАЦИЯ ПО СТАНДАРТИЗАЦИИ • ORGANISATION INTERNATIONALE DE NORMALISATION

Pins and grooved pins — Shear test

Goupilles et goupilles cannelées — Essai de cisaillement

First edition — 1986-11-01

iTeh STANDARD PREVIEW
(standards.iteh.ai)

[ISO 8749:1986](https://standards.iteh.ai/catalog/standards/sist/0562ca46-263d-45cc-99d2-21a623960554/iso-8749-1986)

<https://standards.iteh.ai/catalog/standards/sist/0562ca46-263d-45cc-99d2-21a623960554/iso-8749-1986>

UDC 621.886.1 : 620.176

Ref. No. ISO 8749-1986 (E)

Descriptors : fasteners, pins (mechanics), spring pins, grooved pins, tests, shear tests, test equipment.

Foreword

ISO (the International Organization for Standardization) is a worldwide federation of national standards bodies (ISO member bodies). The work of preparing International Standards is normally carried out through ISO technical committees. Each member body interested in a subject for which a technical committee has been established has the right to be represented on that committee. International organizations, governmental and non-governmental, in liaison with ISO, also take part in the work.

Draft International Standards adopted by the technical committees are circulated to the member bodies for approval before their acceptance as International Standards by the ISO Council. They are approved in accordance with ISO procedures requiring at least 75 % approval by the member bodies voting.

International Standard ISO 8749 was prepared by Technical Committee ISO/TC 2, *Fasteners*.

Users should note that all International Standards undergo revision from time to time and that any reference made herein to any other International Standard implies its latest edition, unless otherwise stated.

iteh STANDARD PREVIEW
(standards.iteh.ai)

ISO 8749:1986
<https://standards.iteh.ai/catalog/standards/sist/26-263d-45cc-99d2-21a623960554/iso-8749-1986>

Pins and grooved pins – Shear test

1 Scope and field of application

This International Standard specifies the test method for shear testing of metallic pins with nominal diameters from 0,8 to 25 mm inclusive.

2 Principle

The test consists of subjecting a pin to a double shear load using a suitable test fixture in a testing machine and recording the maximum load to fracture.

3 Test equipment and method

The shear test is performed in a fixture (a typical fixture is shown in the figure) in which the pin support members and the member for applying the load have holes with diameters con-

forming to the nominal pin size (tolerance H6) and a hardness of not less than 700 HV.

The clearance between the supporting member and the load member shall not exceed 0,15 mm. The shear planes shall be at least one pin diameter away from each end and at least two diameters apart. Pins too short to be tested by double shear shall be tested by shearing two pins simultaneously in a single shear.

Spring pins shall be mounted in the test fixture with the slot upwards.

Pins shall be tested to fracture. The maximum load applied to the pin coincident with or prior to pin fracture shall be regarded as the double shear strength of the pin.

Pins tested for shear strength shall show a ductile shear without longitudinal cracks.

The speed of testing shall not exceed 13 mm/min.

iTech STANDARD PREVIEW
standards.iteh.ai
ISO 8749:1986
http://www.iso.org/standards/std/62461.html
21a623960554/iso-8749-1986

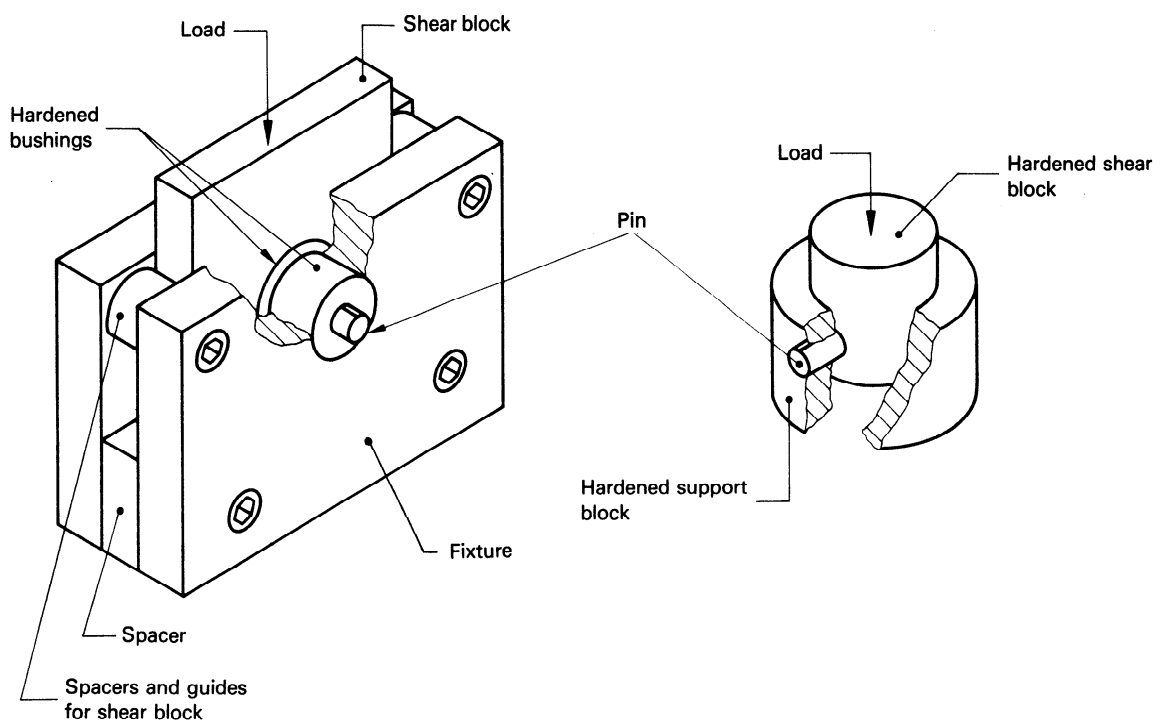

Figure – Typical pin shear test fixture

iTeh STANDARD PREVIEW
(standards.iteh.ai)

This page intentionally left blank

[ISO 8749:1986](#)

<https://standards.iteh.ai/catalog/standards/sist/0562ca46-263d-45cc-99d2-21a623960554/iso-8749-1986>