



# SLOVENSKI STANDARD

## SIST ISO 8759-1:1995

01-april-1995

---

### Kmetijski kolesni traktorji - Prednje tritočkovno priključno drogovje in prednja priključna gred - 1. del: Priključna gred

Agricultural wheeled tractors -- Front-mounted linkage and power take-off -- Part 1: Power take-off

### iTeh STANDARD PREVIEW

Tracteurs agricoles à roues -- Attelage et prise de force montés à l'avant -- Partie 1: Prise de force

[SIST ISO 8759-1:1995](https://standards.iteh.ai/catalog/standards/sist/b7f102d6-c995-449b-8e39-aaddb0d15ea/sist-iso-8759-1-1995)

Ta slovenski standard je istoveten z: **ISO 8759-1:1985**

---

#### **ICS:**

65.060.10      Kmetijski traktorji in prikolice      Agricultural tractors and  
trailed vehicles

**SIST ISO 8759-1:1995**

**en**

**iTeh STANDARD PREVIEW**  
**(standards.iteh.ai)**

SIST ISO 8759-1:1995

<https://standards.iteh.ai/catalog/standards/sist/b7f102d6-c995-449b-8e39-aaddb6fd5ea/sist-iso-8759-1-1995>

---

# International Standard



# 8759/1

---

INTERNATIONAL ORGANIZATION FOR STANDARDIZATION • МЕЖДУНАРОДНАЯ ОРГАНИЗАЦИЯ ПО СТАНДАРТИЗАЦИИ • ORGANISATION INTERNATIONALE DE NORMALISATION

---

## Agricultural wheeled tractors — Front-mounted linkage and power take-off — Part 1: Power take-off

*Tracteurs agricoles à roues — Attelage et prise de force montés à l'avant — Partie 1: Prise de force*

First edition — 1985-12-15

**(standards.iteh.ai)**

[SIST ISO 8759-1:1995](https://standards.iteh.ai/catalog/standards/sist/b7f102d6-c995-449b-8e39-aaddbd6fd5ea/sist-iso-8759-1-1995)

<https://standards.iteh.ai/catalog/standards/sist/b7f102d6-c995-449b-8e39-aaddbd6fd5ea/sist-iso-8759-1-1995>

---

UDC 631.372 : 629.1-494

Ref. No. ISO 8759/1-1985 (E)

Descriptors : agricultural machinery, tractors, power take-off, shafts (rotating), specifications, dimensions.

## Foreword

ISO (the International Organization for Standardization) is a worldwide federation of national standards bodies (ISO member bodies). The work of preparing International Standards is normally carried out through ISO technical committees. Each member body interested in a subject for which a technical committee has been established has the right to be represented on that committee. International organizations, governmental and non-governmental, in liaison with ISO, also take part in the work.

Draft International Standards adopted by the technical committees are circulated to the member bodies for approval before their acceptance as International Standards by the ISO Council. They are approved in accordance with ISO procedures requiring at least 75 % approval by the member bodies voting.

International Standard ISO 8759/1 was prepared by Technical Committee ISO/TC 23, *Tractors and machinery for agriculture and forestry*.

Users should note that all International Standards undergo revision from time to time and that any reference made herein to any other International Standard implies its latest edition, unless otherwise stated.

ITeH STANDARD PREVIEW

(Standards.IteH.ai)

SIST ISO 8759-1:1995

<https://standards.iteh.ai/catalog/standards/sist/b3102d6-c995-449b-8e39-aaddbd6fd5ea/sist-iso-8759-1-1995>

aaddbd6fd5ea/sist-iso-8759-1-1995

# Agricultural wheeled tractors — Front-mounted linkage and power take-off — Part 1: Power take-off

## 1 Scope and field of application

This part of ISO 8759 specifies requirements of type, location, direction of rotation and rotational speed for the power take-off (PTO) fitted to the front of agricultural wheeled tractors.

It applies to the categories of tractors defined in ISO 730/1.

NOTE — Part 2 of ISO 8759 specifies requirements for the front linkage.

## 2 References

ISO 500, *Agricultural tractors — Power take-off and drawbar — Specification.*

ISO 730/1, *Agricultural wheeled tractors — Three-point linkage — Part 1: Categories 1, 2 and 3.*

ISO 4254/1, *Tractors and machinery for agriculture and forestry — Technical means for providing safety — Part 1: General.*

## 3 Definition

For the purposes of ISO 8759, the following definition applies.

**3.1 front of the tractor:** The leading end of the machine when moving in the normally accepted direction of travel on the road, as exemplified by the relative positions of the seat, steering wheel, controls and road lighting equipment.

## 4 Requirements and specifications of power take-off

### 4.1 Type and rotational speed

The power take-off shall be of type 2 (35 mm, 21 splines) in accordance with ISO 500. The rotational speed shall be 1 000 min<sup>-1</sup>.

### 4.2 Direction of rotation

The power take-off shall rotate clockwise when the end of its axle is viewed from the front of the tractor.

### 4.3 Location

The location of the axis of the power take-off shall lie within the shaded rectangle shown in the figure.

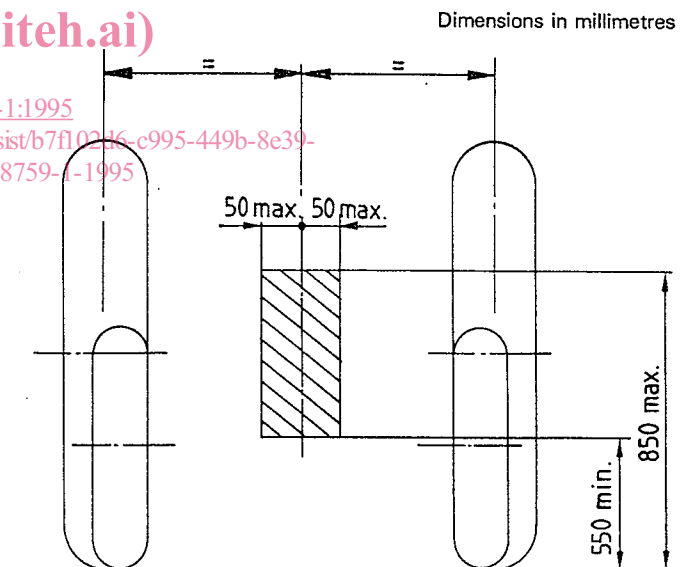

Figure — Location of power take-off

### 4.4 Clearance zone around the power take-off

The clearance zone around the power take-off shall be in accordance with ISO 500.

### 4.5 Protection of the power take-off

The master guard as shown in ISO 500 shall be supplied by the manufacturer and be fixed to the tractor, unless an equivalent protective device ensures the same degree of protection.

NOTE — Further requirements are given in ISO 4254/1.