

INTERNATIONAL STANDARD

ISO
8791-2

First edition
1990-05-01

Paper and board — Determination of roughness/smoothness (air leak methods) —

Part 2:

Bendtsen method

PREVIEW
(standards.iteh.ai)

*Papier et carton — Détermination de la rugosité/du lissé (méthodes du
débit d'air)* ISO 8791-2:1990

[https://standards.iteh.ai/catalog/standards/sist/d58c703b-f0ff-4cfd-b37d-
dea110171551/iso-8791-2-1990](https://standards.iteh.ai/catalog/standards/sist/d58c703b-f0ff-4cfd-b37d-dea110171551/iso-8791-2-1990)
Partie 2: Méthode Bendtsen



Reference number
ISO 8791-2:1990(E)

Foreword

ISO (the International Organization for Standardization) is a worldwide federation of national standards bodies (ISO member bodies). The work of preparing International Standards is normally carried out through ISO technical committees. Each member body interested in a subject for which a technical committee has been established has the right to be represented on that committee. International organizations, governmental and non-governmental, in liaison with ISO, also take part in the work. ISO collaborates closely with the International Electrotechnical Commission (IEC) on all matters of electrotechnical standardization.

Draft International Standards adopted by the technical committees are circulated to the member bodies for voting. Publication as an International Standard requires approval by at least 75 % of the member bodies casting a vote.

International Standard ISO 8791-2 was prepared by Technical Committee ISO/TC 6, *Paper, board and pulps*.

ISO 8791 consists of the following parts, under the general title *Paper and board — Determination of roughness/smoothness (air leak methods)*:

- Part 1: *General method*
- Part 2: *Bendtsen method*
- Part 3: *Sheffield method*
- Part 4: *Print-surf method*

Parts 2 and 3 together cancel and replace ISO 2494:1974, which formerly dealt both with the Bendtsen method and with the Sheffield method.

Annexes A and B form an integral part of this part of ISO 8791.

© ISO 1990

All rights reserved. No part of this publication may be reproduced or utilized in any form or by any means, electronic or mechanical, including photocopying and microfilm, without permission in writing from the publisher.

International Organization for Standardization
Case Postale 56 • CH-1211 Genève 20 • Switzerland

Printed in Switzerland

Paper and board — Determination of roughness/smoothness (air leak methods) —

Part 2: Bendtsen method

1 Scope

This part of ISO 8791 specifies a method for the determination of the roughness of paper and board using the Bendtsen apparatus. It should be read in conjunction with ISO 8791-1.

The method is applicable to paper and board which have Bendtsen roughness values between about 50 ml/min and 1 200 ml/min. It is not suitable for soft papers which allow the land to make a significant impression on the surface or for high air permeance papers which allow a significant flow of air to pass through the sheet, or for papers which will not lie flat under the heavy metal annulus.

2 Normative references

The following standards contain provisions which, through reference in this text, constitute provisions of this part of ISO 8791. At the time of publication, the editions indicated were valid. All standards are subject to revision, and parties to agreements based on this part of ISO 8791 are encouraged to investigate the possibility of applying the most recent editions of the standards indicated below. Members of IEC and ISO maintain registers of currently valid International Standards.

ISO 186:1985, *Paper and board — Sampling to determine average quality*.

ISO 187:1977, *Paper and board — Conditioning of samples*.

ISO 8791-1:1986, *Paper and board — Determination of roughness/smoothness (air leak methods) — Part 1: General method*.

3 Definition

For the purposes of this part of ISO 8791, the following definition applies:

Bendtsen roughness: A measure of the rate at which air will pass between a flat circular land and a sheet of paper or board when tested under specified conditions and at operating pressure.

It is expressed in millilitres per minute.

4 Principle

Clamping a test piece between a flat plate and a circular metal land. Supplying air at a nominal pressure of 1,47 kPa to the space enclosed inside the land and measuring the rate of air flow between the land and the test piece.

5 Apparatus

The apparatus consists of a compressor (A) and pressure stabilizing reservoir (B) to supply air, a flowmeter (D) with a pressure controlling device (C), and a measuring head (E) (see figure 1).

Annex A gives details of care and maintenance of Bendtsen testers.

5.1 Compressor

The compressor shall generate air at a pressure of about 127 kPa. If necessary, filters shall be provided to ensure that the air is clean and free from oil.

5.2 Pressure stabilizing reservoir

The pressure stabilizing reservoir shall have a volume of not less than 10 litres and shall be installed between the compressor and the manostat.

5.3 Manostat

The air pressure shall be controlled by a manostat at the inlet of the flowmeter. Most Bendtsen instruments are provided with three interchangeable manostat weights which control air pressure at $0,74 \text{ kPa} \pm 0,01 \text{ kPa}$, $1,47 \text{ kPa} \pm 0,02 \text{ kPa}$ and $2,20 \text{ kPa} \pm 0,03 \text{ kPa}$. The nominal air pressure should be marked on each weight. However, the standard pressure is $1,47 \text{ kPa}$ and this manostat weight shall be used when testing in accordance with this part of ISO 8791.

5.4 Flowmeter

The flow rate shall be measured by variable-area flowmeters which offer optional flow rate measurements in the ranges 5 ml/min to 150 ml/min, 50 ml/min to 500 ml/min and, on some instruments, 300 ml/min to 3000 ml/min. These three variable-area flowmeters shall be capable of being read to within 2 ml/min, 5 ml/min and 20 ml/min respectively.

NOTE 1 Other methods of measuring flow rates are permitted provided they can be shown to meet the accuracy requirements of this part of ISO 8791. If such a method is used, it should be described in the test report.

One capillary tube shall be provided for verifying the calibration of each variable-area flowmeter. The capillary tubes shall be within the working range of

the relevant flowmeter and shall themselves be accurately calibrated against a reliable standard (e.g. a soap-bubble meter) under the same pressure difference as that in the measuring head (annex B gives details of calibration of capillary tubes and variable-area flowmeters).

5.5 Measuring head

The measuring head consists of an enclosed metal land preferably corrosion-resistant with an optically flat lower surface of $31,5 \text{ mm} \pm 0,2 \text{ mm}$ internal diameter and $0,150 \text{ mm} \pm 0,002 \text{ mm}$ width, and with a mass of $267 \text{ g} \pm 2 \text{ g}$. The tubing used to connect the head to the flowmeter shall be of rubber or plastics, 5 mm internal diameter and not more than 700 mm long.

NOTE 2 A longer length of tubing will result in a significant pressure drop between the flowmeter and the measuring head.

Because the measuring head must be placed on the test piece in such a manner as to avoid any indentation of the surface, it is advisable to provide a mechanical device¹⁾ to lower and raise the head.

5.6 Flat plate

Polished flat plate, preferably glass, upon which the test piece is placed for testing.

5.7 Heavy metal weight

Heavy metal annulus, or other suitably shaped weight, for keeping the test piece flat around the measuring head.

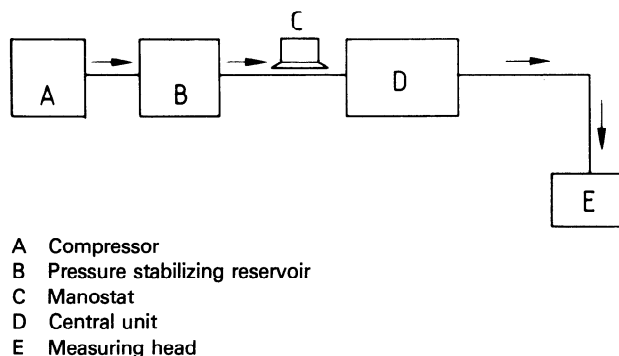

Figure 1 — Circuit diagram of test apparatus

1) A suitable device is described by Zubryn, E. and Hook, G.L. in *Appita* 23(4): 279-290 (January 1970).

6 Sampling

Sampling shall be carried out in accordance with ISO 186.

7 Conditioning

Samples shall be conditioned in accordance with ISO 187.

8 Preparation of test pieces

Not less than 10 test pieces shall be cut for each surface to be tested. The minimum size of each test piece shall be 75 mm × 75 mm and its surfaces shall be identified, e.g. top side and wire side.

The test area shall be free from folds, wrinkles, holes, watermarks or defects normally not inherent in the paper or board. Do not handle that part of the test piece which will become part of the test area.

9 Procedure

9.1 Test atmosphere

Testing shall be carried out under the same atmospheric conditions as those used to condition the test pieces.

9.2 Determination

9.2.1 Place the instrument on a rigid level bench. Level the instrument, ensure that no vibration can cause erroneous readings, and turn on the air supply.

9.2.2 Decide which variable-area flowmeter will be used for the test, selecting, where possible, the variable-area flowmeter which will give a reading in the upper 80 % of the range with the 1,47 kPa manostat weight. Do not use air flows above 1 200 ml/min because at high air flows the pressure drop between the flowmeter and the measuring head can be sufficient to render the calibration of the variable-area flowmeter invalid.

Set the valves at the bottom of the variable-area flowmeters so that air flows through the selected variable-area flowmeter. When the air flow has started, gently place the 1,47 kPa manostat weight on the shaft and start it spinning. It should continue to spin smoothly.

NOTE 3 The manostat weight must not be placed on the shaft until after the air flow has started and must be removed before the air flow is stopped.

9.2.3 Set the valve at the outlet of the flowmeter so that air flows through the smaller (lower) outlet.

9.2.4 Verify the calibration of the variable-area flowmeter by temporarily replacing the measuring head with the appropriate capillary tube. The air flow reading should agree with the correct reading for that capillary tube to within $\pm 5\%$.

9.2.5 With the head connected to the flowmeter, lower the land on to the flat plate and check that the float comes to rest at the bottom of the flowmeter. If not, check the system for air leaks as described in annex A, clause A.1.

9.2.6 Place the test piece on the flat plate, with the surface to be tested uppermost. Gently lower the head on to the test piece, taking particular care to ensure that the land does not make an impression on the surface of the test piece. If the test piece will not lie flat, use the metal annulus to hold it down. Record the flowmeter reading at the top of the float at least 5 s after lowering, with the reading accuracy indicated in 5.4.

9.2.7 Test the remaining test pieces by the same method.

9.2.8 After completing the tests, remove the manostat weight and then turn off the air supply.

10 Expression of results

10.1 Calculate the mean of the air flow readings to two significant figures for each side to be tested.

10.2 Calculate the standard deviation or coefficient of variation to one significant figure for each side tested.

11 Test report

The test report shall include the following particulars:

- a) reference to this part of ISO 8791;
- b) date and place of testing;
- c) all the information necessary for complete identification of the sample;

- d) the type of instrument used;
- e) the temperature and relative humidity used for the test;
- f) the number of test pieces tested;
- g) the pressure difference used, in kilopascals;
- h) the flowmeter range used;
- i) arithmetic mean result (as calculated in 10.1);
- j) standard deviation or coefficient of variation (as calculated in 10.2);
- k) any deviations from the procedure specified.

iTeh STANDARD PREVIEW
(standards.iteh.ai)

ISO 8791-2:1990

<https://standards.iteh.ai/catalog/standards/sist/d58c703b-f0ff-4cfd-b37d-dea110171351/iso-8791-2-1990>

Annex A (normative)

Care and maintenance of Bendtsen testers

A.1 Checking for air leaks

Check for air leaks by testing the circular land against the flat plate as described in 9.2.5, using the 5 ml/min to 150 ml/min flowmeter. If the rotor does not remain at rest at the bottom of the flowmeter, check the plate and the land surfaces for damage and imperfections, and check the condition of the tubing and the connections.

A.2 Manostat weight

Care shall be taken when handling the manostat weight to avoid damage to the rim. In particular, it shall not be placed on the shaft until the air flow has been started and shall be removed before it has stopped.

Check that the axial hole through the weight is clean.

Disconnect the measuring head and attach to that end of the tube a T-piece with a suitable capillary tube attached in the "straight-through" position and a water manometer attached to the side position. Check that the pressure at this point is within 5 % of the desired manometer reading when the air flow is as follows:

a) 5 ml/min to 150 ml/min variable-area flowmeter

Air flow (ml/min)	10	100	150
Desired manometer reading (mm)	152	150	148

b) 50 ml/min to 500 ml/min variable-area flowmeter

Air flow (ml/min)	50	100	300	500
Desired manometer reading (mm)	152	151	149	146

c) 300 ml/min to 3 000 ml/min variable-area flowmeter

Desired manometer reading (mm): 150 ± 10 at all flow rates up to 1 200 ml/min

To ensure that the pressure drop between this point and the test piece is not significant, the connecting tube to the head shall be 5 mm in internal diameter and not more than 700 mm long.

The manostat weights shall not be lubricated.

A.3 Movement of floats

Check that the floats spin freely in the variable-area flowmeter tubes. Although a float which does not spin well may give stable readings, a spinning float has a self-cleaning action and is less likely to give errors by sticking to the walls of the tubes. Check the condition of the flutes as this mainly determines whether it will spin properly, especially at low flow rates. Other factors important for good spinning are mechanical symmetry and condition of the top rim.

If a float becomes wedged in the spring at the bottom or top of a variable-area flowmeter tube, tap the instrument lightly while passing air through the tube. If this fails to free the float, loosen the bottom and top bushings around the tubes with a special spanner, take off the metal block at the top of the variable-area flowmeter and remove the tube. A recurrence of sticking can be prevented by adjusting the shape of the springs. The bottom spring should terminate in a horizontal loop centred in the variable-area flowmeter. The top spring should terminate in a vertical loop centred in the variable-area flowmeter.

A.4 Cleaning variable-area flowmeters

If a variable-area flowmeter tube or float is dirty, giving high readings, remove the float from the tube, clean both with carbon tetrachloride or similar solvent, then dry in the air stream.

A liquid detergent may be used as an alternative to carbon tetrachloride. If so, add to the tube, flush with water, reversing the flow several times, and use diluted aqueous solution [about 10 % (V/V)] to clean the float. Finally, rinse both with distilled water, and dry in an air stream.

Replace faulty tubes.

A.5 Air tubes

Tubing should be regularly inspected for signs of deterioration and replaced if necessary. All tubing should be replaced at least once a year, whether or not it appears defective.

A.6 Capillary tubes

Capillary tubes can become dirty rather easily and, therefore, should be inspected regularly and carefully with a magnifying glass and if necessary, cleaned in accordance with the procedure in clause A.4.

iTeh STANDARD PREVIEW (standards.iteh.ai)

ISO 8791-2:1990

<https://standards.iteh.ai/catalog/standards/sist/d58c703b-f0ff-4cfd-b37d-dea110171351/iso-8791-2-1990>

Annex B (normative)

Calibration of capillary tubes and variable-area flowmeters

B.1 Checking variable-area flowmeters with capillary tubes

Flowmeter floats appear to be susceptible to wear. If a scale reading with the capillary tube connected differs by more than 5 % from the indicated value, the following procedure should be adopted.

- a) Check the variable-area flowmeter against the capillary tube normally used for an adjacent variable-area flowmeter.
- b) If both readings are high, check the variable-area flowmeter tube and float for cleanliness and clean if necessary.
- c) If both readings are low, check for restrictions or leaks in the system, for example kinks or leaks in the plastics or rubber tube.
- d) If the two readings do not agree, or if the faults found in b) or c) cannot be identified, calibrate the variable-area flowmeter according to clause B.2.
- e) From the results of d), determine whether the variable-area flowmeter or capillary tube is at fault and replace if necessary.

B.2 Checking calibration of variable-area flowmeter

Variable-area flowmeters may be calibrated by a soap-bubble meter of which there are several designs. Figure B.1 is a diagrammatic representation of a suitable meter.

B.2.1 Apparatus and product

B.2.1.1 Soap-bubble meter, consisting of:

- glass flask or bottle, capacity 1 litre;
- volumeter, with graduation marks indicating 100 ml, 250 ml and 1 500 ml; the different ranges may be achieved with replaceable volumeters;

- needle valve;
- glass and rubber tubing of as large an internal diameter as practicable to minimize pressure drop.

NOTE 4 Other calibration procedures are permitted provided they are at least as accurate as the procedure described in the present annex.

B.2.1.2 Stop-watch.

B.2.1.3 Soap solution: 3 % to 5 % liquid detergent in distilled water.

B.2.2 Procedure

To calibrate the variable-area flowmeters, disconnect the measuring head from the downstream end of the rubber or plastics tubing and connect in its place the soap-bubble meter at A. Set the valves to deliver through the variable-area flowmeter to be calibrated to the soap-bubble meter. Adjust the needle valve to give a conveniently measurable air flow and ensure that the flow rate remains constant. Rapidly squeeze the rubber bulb at the bottom of the volumeter so that a soap bubble enters the volumeter tube. Note the time in seconds for it to move between marks representing a known volume and record the flowmeter reading. The volumeter range should be chosen so that time measurements are in excess of 30 s. Repeat the procedure at about six air flows distributed over the upper 80 % of the flowmeter working range. Note the atmospheric pressure.

NOTE 5 At high air flows the pressure drop in the system can cause errors in calibration. To minimize these errors, the length and diameter of the tubing must be the same in calibration as in testing.

B.2.3 Calculation

Calculate the true air flow, in millilitres per minute, from each measured time and volume and check that the flowmeter reading is within 5 % of this flow. If not, check the operation of the flowmeter and if necessary construct a calibration graph.