

INTERNATIONAL
STANDARD

ISO
8820-2

First edition
1994-08-15

**Road vehicles — Blade-type electric
fuse-links —**

Part 2:
Dimensions

STANDARD PREVIEW
(standards.iteh.ai)

Véhicules routiers — Fusibles électriques plats —

Partie 2: Dimensions
<https://standards.iteh.ai/en/ISO-8820-2:1994>
<https://standards.iteh.ai/en/84c15bfc-a2cc-4a0e-8837-d57320ca88fl/iso-8820-2-1994>



Reference number
ISO 8820-2:1994(E)

Foreword

ISO (the International Organization for Standardization) is a worldwide federation of national standards bodies (ISO member bodies). The work of preparing International Standards is normally carried out through ISO technical committees. Each member body interested in a subject for which a technical committee has been established has the right to be represented on that committee. International organizations, governmental and non-governmental, in liaison with ISO, also take part in the work. ISO collaborates closely with the International Electrotechnical Commission (IEC) on all matters of electrotechnical standardization.

Draft International Standards adopted by the technical committees are circulated to the member bodies for voting. Publication as an International Standard requires approval by at least 75 % of the member bodies casting a vote.

International Standard ISO 8820-2 was prepared by Technical Committee ISO/TC 22, *Road vehicles*, Subcommittee SC 3, *Electrical and electronic equipment*.

<https://standards.iteh.ai/catalog/standards/sist/84c15bfc-a2cc-4a0e-8837-157889-8837/iso-8820-2-1994>

ISO 8820 consists of the following parts, under the general title *Road vehicles — Blade-type electric fuse-links*:

- *Part 1: Rated current, identification, test procedures and performance requirements*
- *Part 2: Dimensions*
- *Part 3: Test fixture*

Annex A forms an integral part of this part of ISO 8820.

© ISO 1994

All rights reserved. Unless otherwise specified, no part of this publication may be reproduced or utilized in any form or by any means, electronic or mechanical, including photocopying and microfilm, without permission in writing from the publisher.

International Organization for Standardization
Case Postale 56 • CH-1211 Genève 20 • Switzerland

Printed in Switzerland

Road vehicles — Blade-type electric fuse-links —

Part 2: Dimensions

1 Scope

This part of ISO 8820 establishes the requirements for the overall dimensions of blade-type electric fuse-links with rated currents up to and including 30 A, used to protect on-board wiring harnesses and electrical equipment, with a rated voltage up to and including 32 V, of road vehicles and similar applications from overcurrent. Interruption of the circuit is achieved as a result of the fuse element melting.

Rated current, identification, test procedures and performance of blade-type electric fuse-links are specified in ISO 8820-1, and the test fixture in ISO 8820-3.

2 Dimensions

Blade-type electric fuse-links shall conform to the dimensions shown in figure 1. Dimensions of details not specified are left to the manufacturer's discretion.

NOTE 1 Annex A provides dimensions for an optional fuse-link. There are dimensional differences between these two fuse-links. The preferred fuse-link shown in figure 1 is interchangeable with known existing fuse blocks, whereas the optional fuse-link shown in annex A is not interchangeable in all instances.

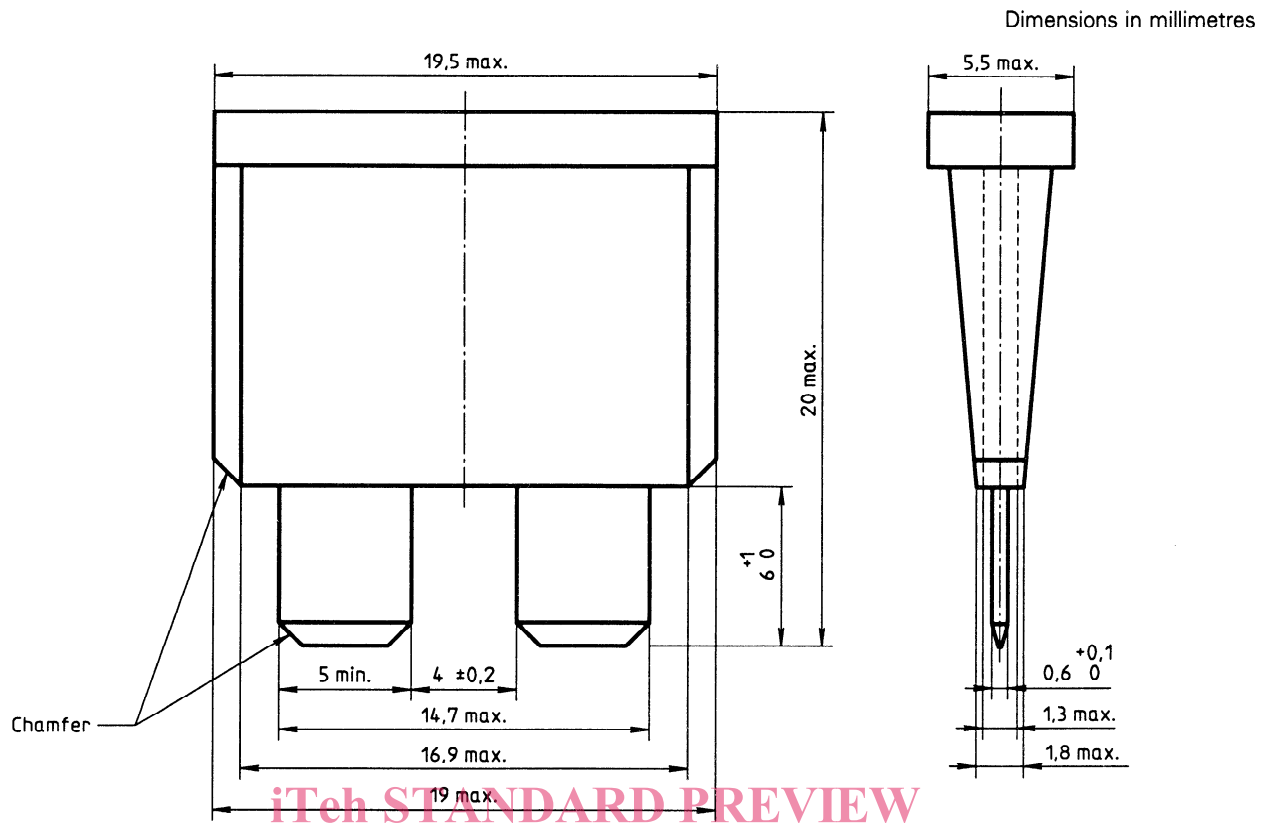

iTeh STANDARD PREVIEW
(standards.iteh.ai)

Figure 1

ISO 8820-2:1994

<https://standards.iteh.ai/catalog/standards/sist/84c15bfc-a2cc-4a0e-8837-d57320ca88fl/iso-8820-2-1994>

Annex A
(normative)

Optional fuse-link

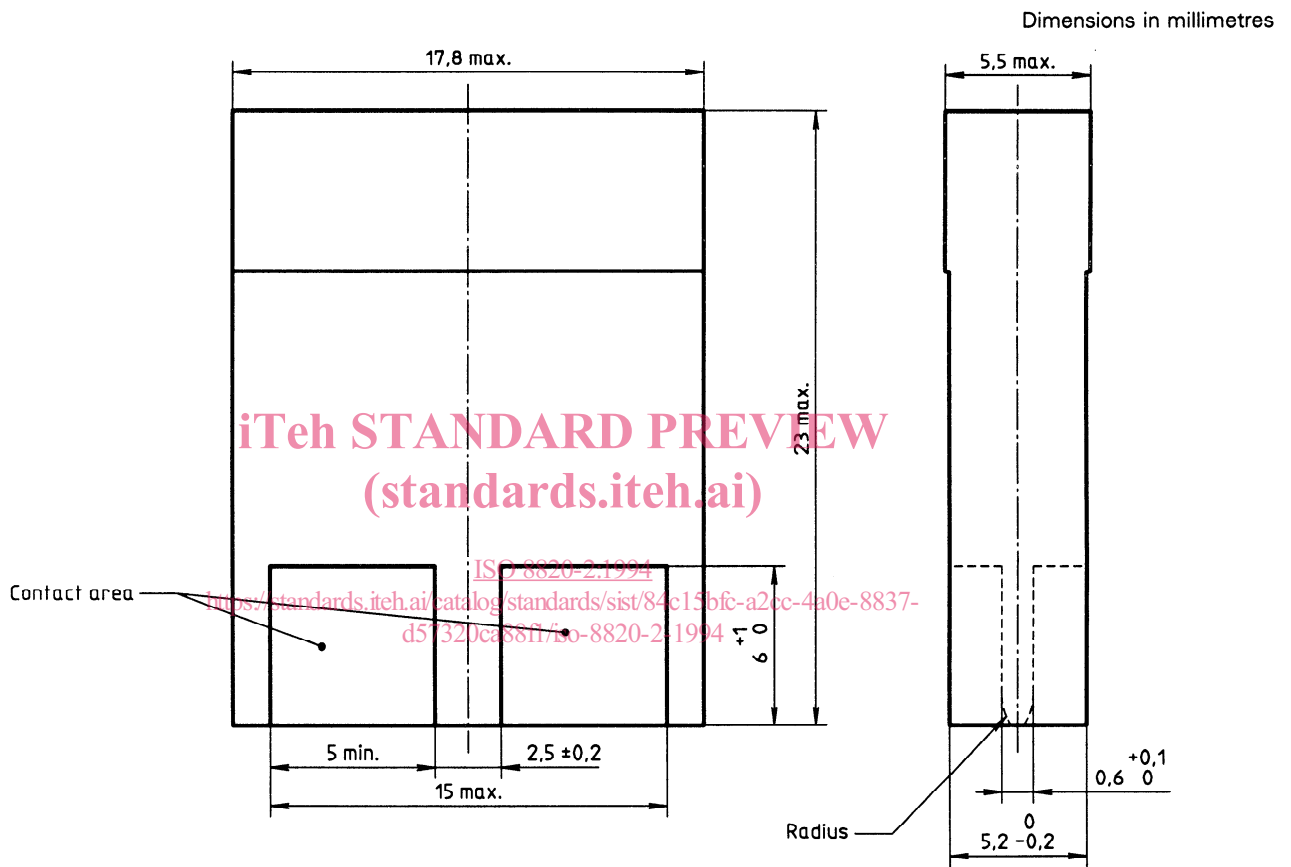

Figure A.1

iTeh STANDARD PREVIEW
This page intentionally left blank
(standards.iteh.ai)

ISO 8820-2:1994

<https://standards.iteh.ai/catalog/standards/sist/84c15bfc-a2cc-4a0e-8837-d57320ca88fl/iso-8820-2-1994>

iTeh STANDARD PREVIEW
This page intentionally left blank
(standards.iteh.ai)

ISO 8820-2:1994

<https://standards.iteh.ai/catalog/standards/sist/84c15bfc-a2cc-4a0e-8837-d57320ca88fl/iso-8820-2-1994>

iTeh STANDARD PREVIEW
(standards.iteh.ai)

ISO 8820-2:1994

<https://standards.iteh.ai/catalog/standards/sist/84c15bfc-a2cc-4a0e-8837-d57320ca88f1/iso-8820-2-1994>

ICS 43.040.10

Descriptors: road vehicles, electric equipment, fuse-links, dimensions.

Price based on 3 pages
