

INTERNATIONAL STANDARD

ISO
8840

First edition
1987-09-15



INTERNATIONAL ORGANIZATION FOR STANDARDIZATION
ORGANISATION INTERNATIONALE DE NORMALISATION
МЕЖДУНАРОДНАЯ ОРГАНИЗАЦИЯ ПО СТАНДАРТИЗАЦИИ

Refractory materials — Determination of bulk density of granular materials (grain density)

Matériaux réfractaires — Détermination de la masse volumique apparente des matériaux en grains (masse volumique des grains)

(standards.iteh.ai)

ISO 8840:1987

<https://standards.iteh.ai/catalog/standards/sist/3e97121d-acad-4876-b8c2-317ac5cf630a/iso-8840-1987>

Reference number
ISO 8840: 1987 (E)

Foreword

ISO (the International Organization for Standardization) is a worldwide federation of national standards bodies (ISO member bodies). The work of preparing International Standards is normally carried out through ISO technical committees. Each member body interested in a subject for which a technical committee has been established has the right to be represented on that committee. International organizations, governmental and non-governmental, in liaison with ISO, also take part in the work.

Draft International Standards adopted by the technical committees are circulated to the member bodies for approval before their acceptance as International Standards by the ISO Council. They are approved in accordance with ISO procedures requiring at least 75 % approval by the member bodies voting.

International Standard ISO 8840 was prepared by Technical Committee ISO/TC 33, *Refractories*.

Users should note that all International Standards undergo revision from time to time and that any reference made herein to any other International Standard implies its latest edition, unless otherwise stated.

iTeh STANDARD PREVIEW
(standards.iteh.ai)

ISO 8840:1987
<https://standards.iteh.ai/catalog/standards/sis/5c9712fd-acad-4876-b8c2-317ac5cf630a/iso-8840-1987>

Refractory materials — Determination of bulk density of granular materials (grain density)

1 Scope and field of application

This International Standard specifies two methods for the determination of the bulk density of granular refractory materials (grain density) having a grain size larger than 2 mm :

- Method 1 : the mercury method with vacuum
- Method 2 : the arrested water absorption method.

Method 1 is intended as the referee method.

Depending on the nature of the material tested, the two methods may give different results. Any statement of the value of a bulk density shall therefore be accompanied by an indication of the method used or to be used in case of dispute.

The same method shall be used for the determination of the volume of the sample, for selecting and preparing the sample, for calculating the bulk density and for presenting the test report.

2 References

ISO 383, *Laboratory glassware — Interchangeable conical ground joints.*

ISO 385-1, *Laboratory glassware — Burettes — Part 1 : General requirements.*

ISO 5018, *Refractory materials — Determination of true density.*

ISO 8656, *Refractory products — Raw materials and unshaped products — Sampling.*¹⁾

3 Definitions

For the purpose of this International Standard, the following definitions apply.

3.1 bulk density of a granular material (grain density) : The ratio of the mass of a quantity of the material to the total volume of its grains, including the volume of any closed pores within the grains.

3.2 closed pores : Pores that are not penetrated by a liquid in which the grains are immersed.

4 Principle

Measurement of the volume of a given mass of a granular material by displacement of a liquid.

5 Sampling

Sampling shall be carried out in accordance with ISO 8656 or with another standard sampling scheme agreed between the interested parties.

6 Preparation, number and size of test samples

6.1 Preparation of samples

The material to be tested shall consist of fractions or groups of fractions with grain sizes above 2 mm. Laboratory samples shall be produced by sieving, after any preliminary comminution of the material above 5,6 mm grain size. Test results can be affected by the comminution technique and the equipment used.

Any dust or loose particles adhering to the grains shall be removed before testing by washing or, with materials sensitive to moisture or humidity, by air blowing.

6.2 Number of samples

Take at least three test samples from the laboratory sample and carry out one determination of bulk density on each test sample.

6.3 Size of samples

The size of test samples to be taken depends on the grain size and the homogeneity of the material being tested. Recommended sizes are shown in table 1.

Table 1 — Size of test samples

Grain fraction (mm)	Method	Size of test samples (g)	
		Good homogeneity	Poor homogeneity
2,0 to 5,6	1	100	200
	2	50	50

1) At present at the stage of draft.

7 Determination of mass of test sample

Dry the test sample to constant mass in the drying oven maintained at 110 ± 5 °C and allow it to cool to ambient temperature in the desiccator. Weigh the test sample to the nearest 0,1 g on the balance.

8 Determination of volume of test sample — Method 1 : Mercury method with vacuum

NOTE — Method 1 is preferred as a referee method because of its reproducibility and simplicity in use. However, mercury is known to be a hazardous substance, and therefore method 2 (see clause 9) is recommended for all routine purposes.

8.1 Principle

Determination of the volume of the test sample by the mercury displacement method with a vacuum below 30 mbar¹⁾ residual pressure, preferably with a residual pressure of 1,33 mbar (approximately 1 Torr).

8.2 Apparatus

8.2.1 Vacuum pycnometer : a vessel as shown in figure 1 (incorporating conical ground glass joints in accordance with ISO 383).

8.2.2 Test arrangement, as shown in figure 2.

8.3 Determination of mass of empty vacuum pycnometer

Clean and dry the empty vacuum pycnometer (8.2.1) and weigh it to the nearest 0,1 g.

NOTE — This weighing is unnecessary if all the determinations are carried out at the same temperature.

8.4 Determination of mass of pycnometer filled with mercury

Evacuate the vacuum pycnometer and fill it with mercury by suction until mercury emerges from the capillary tube (see figure 2). Close the stopcocks 2 and 5 of the pycnometer in that order and disconnect the apparatus from the vacuum pump. Pour off the surplus mercury that has come out of the capillary tube and remove the mercury remaining in the suction tube, up to stopcock 2, with a steel wire. Weigh the pycnometer filled with mercury to the nearest 0,1 g.

8.5 Determination of mass of pycnometer containing test sample and filled with mercury

Transfer the dried and weighed test sample (see clause 7), without loss, into the pycnometer and fill the pycnometer,

under vacuum, with mercury as specified in 8.4. This will give an average pressure on the grains of about 265 mbar. Weigh the pycnometer and contents to the nearest 0,1 g. Thereupon, under vacuum, remove the mercury from the vessel. Determine the amount of mercury still remaining in the test sample by weighing the sample after the mercury adhering to it has been removed and by finding the difference from the original mass of the test sample. If the mass of mercury remaining in the test sample is over 5 % of the original mass of the sample, state the amount, expressed as a percentage by mass, in the test report.

8.6 Calculation of volume of test sample

If the weighings in accordance with 8.4 and 8.5 were made at a constant temperature (and therefore with a constant mercury density), the volume V_R of the test sample is given, in millilitres, by the equation

$$V_R = \frac{m_G + m_P - m_T}{\rho}$$

If the weighings in accordance with 8.4 and 8.5 were made at different temperatures (and thus with different mercury densities), the volume V_R of the test sample is given, in millilitres, by the equation

$$V_R = \frac{m_G - m_L}{\rho_1} - \frac{m_T - m_L - m_P}{\rho_2}$$

where

m_G is the mass, in grams, of the pycnometer filled with mercury only;

m_T is the mass, in grams, of the evacuated pycnometer filled with test sample and mercury;

m_L is the mass, in grams, of the empty pycnometer;

m_P is the mass, in grams, of the test sample;

ρ is the density, in grams per cubic centimetre, of mercury if calibration and measurement were carried out at the same temperature;

ρ_1 is the density, in grams per cubic centimetre, of mercury when determining the filled mass of the pycnometer containing mercury;

ρ_2 is the density, in grams per cubic centimetre, of mercury when determining the filled mass of the pycnometer containing both test sample and mercury.

NOTE — The density of mercury as a function of temperature is given in table 2.

1) 1 bar = 10^5 Pa

Table 2 — Density of mercury as a function of temperature

Temperature °C	Density g/cm ³	Temperature °C	Density g/cm ³
15	13,559	23	13,539
16	13,556	24	13,536
17	13,554	25	13,534
18	13,551	26	13,532
19	13,549	27	13,529
20	13,546	28	13,527
21	13,544	29	13,524
22	13,541	30	13,522

9 Determination of volume of test sample — Method 2 : Arrested water absorption method

NOTE — This method is not suitable for materials which are hydrated by water.

9.1 Apparatus

9.1.1 Beaker, of capacity 150 ml.

9.1.2 Funnel, with an upper diameter of approximately 100 mm.

9.1.3 Calibrated burette, 100 ml, graduated in 0,2 ml, complying with the requirements of ISO 385-1.

9.1.4 Flat-weave cotton towel.

9.1.5 Burette magnifier.

9.2 Determination of volume of test sample

Transfer the dried and weighed test sample (see clauses 6 and 7) to the beaker (9.1.1) and add water at ambient temperature until the sample is covered. Free the burette from grease and wash it out immediately before each use. Fill it with water to a level between the 20 and the 25 ml marks and allow it to drain for 1 min, then take the initial reading, by estimation, to one-tenth of a division (0,05 ml) with the aid of the magnifier. Then attach the funnel (9.1.2) to the burette (9.1.3) by means of a piece of plastic tubing.

Saturate the cotton towel (9.1.4) with water and wring it out by hand as dry as possible before each determination. Fold the towel to form a pad with four to six thicknesses of cloth.

When the test sample has been soaking for at least 2 min, place a cover glass over the beaker to retain the sample and pour the water off as completely as possible. Transfer the test sample to the towel and blot it with the towel until the wet sheen on the grains has disappeared. Pour the test sample through the funnel into the burette, folding the towel to facilitate this operation. Read the final level, by estimation, to 0,05 ml, with the aid of the magnifier (9.1.5).

The volume of the test sample is the difference between the final and initial readings.

10 Calculation of results

The bulk density ρ_R is given, in grams per cubic centimetre, by the equation

$$\rho_R = \frac{m}{V_R}$$

where

m is the mass, in grams, of the dried test sample (see clause 7);

V_R is the volume, in millilitres, of the test sample (see clause 8 or 9).

11 Test report

The test report shall include the following information :

- a reference to this International Standard;
- the method used;
- the designation of the material tested (manufacturer, type, batch number, etc.);
- the range of grain size and the mass of the test samples;
- the bulk density (both individual values and the arithmetic mean for the material);
- the mass of mercury remaining in the test sample, expressed as a percentage by mass (for Method 1 only);
- the name of the testing establishment;
- the date of the test.

Dimensions in millimetres

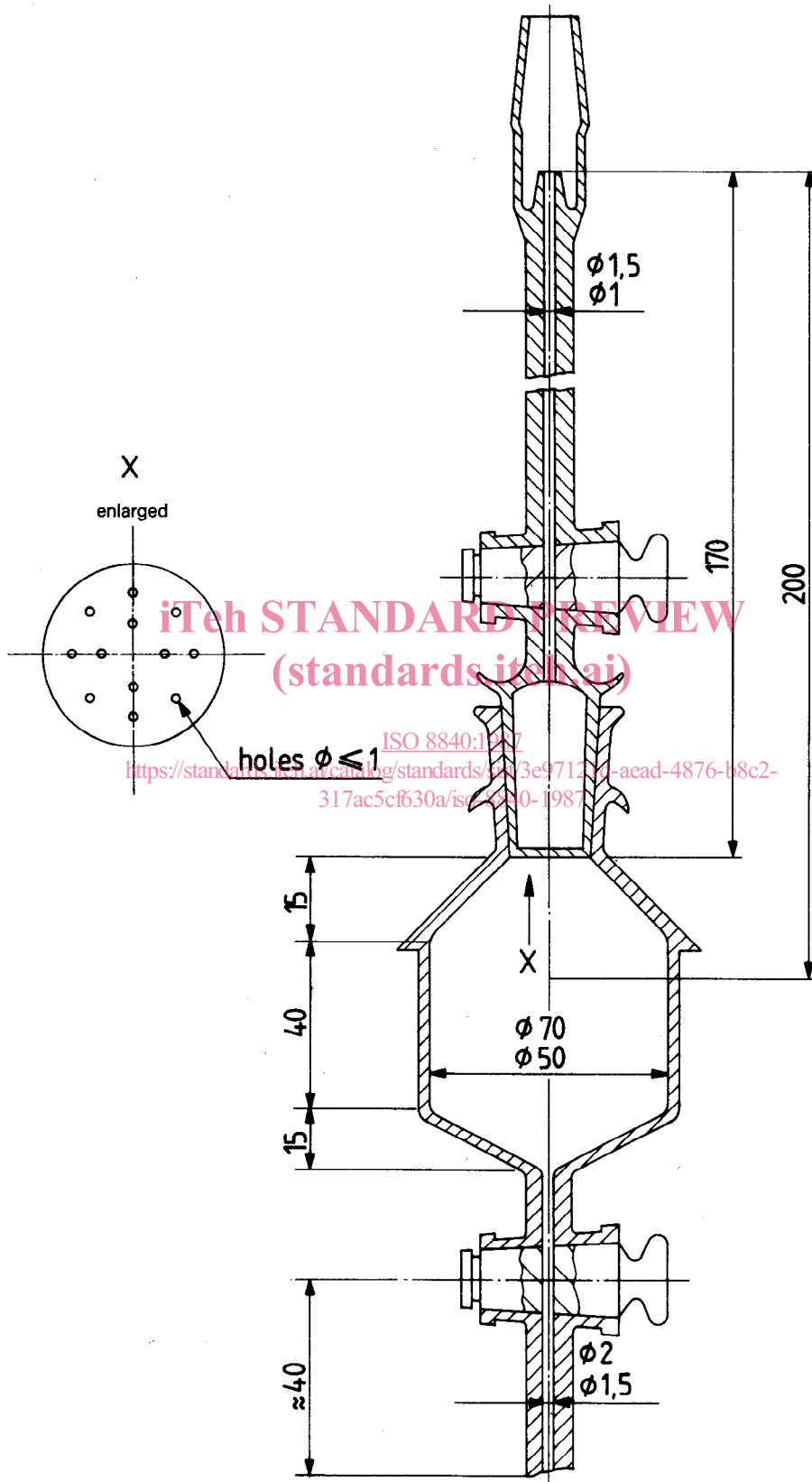
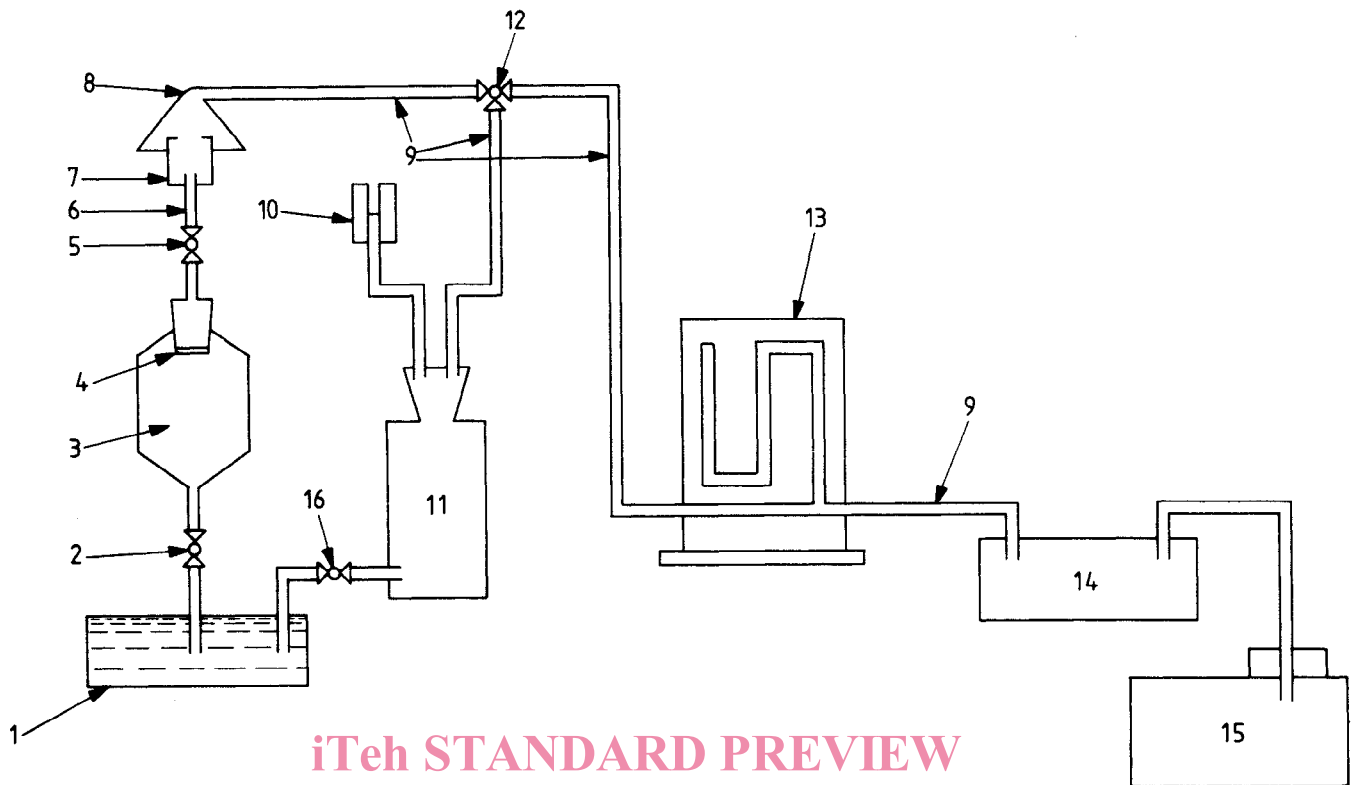

Figure 1 — Vacuum pycnometer



iTeh STANDARD PREVIEW
(standards.iteh.ai)

<https://standards.iteh.ai/standards/iso/8840/1987>
<https://standards.iteh.ai/standards/iso/8840/1987>

- 1 Dish for mercury
- 2 Stopcock
- 3 Pycnometer lower part
- 4 Glass seal with holes (diameter < 1 mm)
- 5 Stopcock
- 6 Pycnometer upper part
- 7 Capillary and overflow tube
- 8 Pycnometer vacuum connection
- 9 Vacuum tubing
- 10 Mercury extraction bush
- 11 Mercury reservoir
- 12 Three-way tap
- 13 Vacuum manometer
- 14 Woulfe's bottle
- 15 Vacuum pump
- 16 Stopcock

Figure 2 — Schematic representation of the test arrangement

iTeh STANDARD PREVIEW
(standards.iteh.ai)

ISO 8840:1987

<https://standards.iteh.ai/catalog/standards/sist/3e97121d-acad-4876-b8c2-317ac5cf630a/iso-8840-1987>

UDC 666.76-492.3 : 531.755.22

Descriptors : refractory materials, granular materials, tests, physical tests, determination, density (mass/volume), bulk density.

Price based on 5 pages
