

# INTERNATIONAL STANDARD

# ISO 8853

First edition  
1989-04-01

---

---

## Safety harnesses for competition drivers — Requirements and test methods

*Harnais de sécurité pour les pilotes de compétitions automobiles — Exigences et  
méthodes d'essai*



Reference number  
ISO 8853: 1989 (E)

ISO 8853:1989  
https://standards.iteh.ai/catalog/standards/sist/8d3a12f6-27-4e17-88a2-b6a7e749a7b/iso-8853-1989  
iteh STANDARD PREVIEW  
(standards.iteh.ai)

<b>Contents</b>	<b>Page</b>
Foreword .....	iii
<b>1</b> Scope .....	<b>1</b>
<b>2</b> Normative references .....	<b>1</b>
<b>3</b> Definitions .....	<b>1</b>
<b>4</b> General requirements .....	<b>1</b>
<b>5</b> Specific requirements .....	<b>2</b>
<b>6</b> Test methods .....	<b>3</b>
<b>7</b> Marking .....	<b>5</b>
<b>Annexes</b>	
<b>A</b> Description of trolley, seat, anchorages and stopping device .....	<b>6</b>
<b>B</b> Description of manikin .....	<b>10</b>
<b>C</b> Trolley deceleration curve as function of time .....	<b>17</b>
<b>D</b> Corrosion test .....	<b>18</b>
<b>E</b> Marking .....	<b>19</b>
<b>F</b> Requirements for installation of safety harnesses .....	<b>20</b>

## Foreword

ISO (the International Organization for Standardization) is a worldwide federation of national standards bodies (ISO member bodies). The work of preparing International Standards is normally carried out through ISO technical committees. Each member body interested in a subject for which a technical committee has been established has the right to be represented on that committee. International organizations, governmental and non-governmental, in liaison with ISO, also take part in the work. ISO collaborates closely with the International Electrotechnical Commission (IEC) on all matters of electrotechnical standardization.

Draft International Standards adopted by the technical committees are circulated to the member bodies for approval before their acceptance as International Standards by the ISO Council. They are approved in accordance with ISO procedures requiring at least 75 % approval by the member bodies voting.

International Standard ISO 8853 was prepared by Technical Committee ISO/TC 22, *Road vehicles*, in collaboration with FISA (Fédération internationale du sport automobile).

Annexes A to F form an integral part of this International Standard.

# **ITeH STANDARD PREVIEW**

## **(standards.iteh.ai)**

ISO 8853:1989

<https://standards.iteh.ai/catalog/standards/sis/98d3a12f-4127-4ef7-88a2-b6a7ef749a7b/iso-8853-1989>

This page intentionally left blank

# Safety harnesses for competition drivers — Requirements and test methods

## 1 Scope

This International Standard specifies requirements and test methods for five- or six-point safety harnesses for use by drivers in automobile competitions, in order to reduce the risk of bodily harm in an accident.

It applies to safety harnesses to equip single-seater and two-seater racing cars designed and manufactured to run on closed circuits.

## 2 Normative references

The following standards contain provisions which, through reference in this text, constitute provisions of this International Standard. At the time of publication, the editions indicated were valid. All standards are subject to revision, and parties to agreements based on this International Standard are encouraged to investigate the possibility of applying the most recent editions of the standards listed below. Members of IEC and ISO maintain registers of currently valid International Standards.

ISO 3795: 1976, *Road vehicles — Determination of burning behaviour of internal materials for motor vehicles.*

ISO 6487: 1987, *Road vehicles — Measurement techniques in impact tests — Instrumentation.*

## 3 Definitions

For the purposes of this International Standard, the following definitions apply.

**3.1 safety harness:** Arrangement of straps with a securing buckle, adjusting devices and attachments.

**3.2 harness type:** Harnesses differing substantially from one another. The differences may relate in particular to:

- rigid parts (buckle, attachments, etc.);
- the material, weave, dimensions and colour of the straps;
- geometry of the harness.

**3.3 shoulder strap:** Part of the harness which restrains the upper portion of the body of the wearer and consists of a strap passing over each shoulder.

**3.4 lap belt:** Belt which passes across the front of the wearer's pelvic region.

**3.5 crotch straps:** Part of a harness consisting of straps each passing across a thigh of the wearer in order to restrain any tendency of the wearer to slide forward under the lap belt.

**3.6 strap:** Flexible component designed to hold the body and to transmit stresses to the belt anchorages.

**3.7 adjusting device:** Device to permit the harness to be adjusted to the requirements of the wearer.

**3.8 securing buckle:** Quick-release device securing all straps, thus enabling the wearer to be restrained by the straps.

**3.9 attachments:** Parts of the harness, including the necessary securing components, supplied by the harness manufacturer which allow the harness to be attached to the belt anchorages.

**3.10 anchorages:** Part of the vehicle structure to which the harness is secured.

**3.11 load-spreading device:** Device such as a pad, generally placed under the buckle in order to spread the load transmitted to the wearer during deceleration.

## 4 General requirements

### 4.1 Design

The safety harness shall be designed to restrain the driver properly in his seat. It shall comprise two shoulder straps, one lap belt and two crotch straps<sup>1)</sup>.

The straps should be of the shortest possible length, and preferably cut to suit each individual wearer; it is recommended that adjustment for other wearers, if necessary, is made by changing the seat.

1) The crotch straps may consist of a single flexible piece and a single attachment.

The rigid parts of the harness such as buckles, adjusting devices, attachments, shall not have sharp edges liable to cause wear or breakage of the straps by chafing.

Requirements on installation of safety devices are given in annex F.

## 4.2 Adjusting devices

If adjusters are used, it shall not be possible for them to work loose. It is recommended that they be positioned near to anchorage points. Adjusters shall in no circumstances be placed on the buckle.

## 4.3 Securing buckle

The securing buckle shall be placed so as to be easily operable by the wearer or by a person outside the car.

The opening<sup>1)</sup> of the buckle shall produce, by itself alone and in one turning motion in either direction, the simultaneous release of all the straps holding the wearer.

The contact area of the buckle with the body of the wearer shall be between 2 000 mm<sup>2</sup> and 4 000 mm<sup>2</sup>.

The buckle shall not permit partial engagement of the tongues.

The buckle opening system shall be designed such that each tongue is ejected on release or that the latching mechanism shall remain in the open position.

## 4.4 Load-spreading devices

Load-spreading devices shall be as wide as is practical — at least the width of the strap — and shall be at least 10 mm wider than the buckle at the level of the buckle.

## 5 Specific requirements

### 5.1 Strap

**5.1.1** The characteristics of the straps shall be such as to ensure that their pressure on the wearer's body is distributed as evenly as possible over their width and that they do not twist under tension.

**5.1.2** The width of the strap under a load of 980 daN and measured in conformity with 6.1 shall not be less than 44 mm.

As an exception to this, the parts of the crotch straps which are not in contact with the wearer's thighs may have a minimum width of 25 mm, always provided that the breaking load requirement is met.

**5.1.3** The breaking load of the straps measured in conformity with 6.1 shall not be less than 2 450 daN. This load shall be reduced to 1 130 daN for the crotch straps.

### 5.2 Securing buckle

NOTE — The specifications in 5.2.1 and 5.2.2 have also been set in order to avoid inadvertent operation of the buckle.

**5.2.1** A pre-release free movement shall extend through a minimum angle of 25° measured on either side of the closed position before the release mechanism begins to operate.

**5.2.2** The torque required to open the buckle, measured in accordance with 6.2, shall be between 1 N.m and 3,5 N.m.

**5.2.3** The locking mechanism of the buckle, without the tongues being inserted, shall be capable of resisting repeated operation; it shall be operated 2 500 times in each direction, under conditions of normal use.

**5.2.4** The surface touched to open the buckle shall be measured in the plane projection perpendicular to the initial movement of the lever and at least equal to 200 mm<sup>2</sup>; when buckled, it shall be in a fairly horizontal plane under conditions of normal use. The force applied at the geometrical centre of the 200 mm<sup>2</sup> surface to obtain the torque, measured in accordance with 6.2, shall be calculated and be less than 9 daN.

**5.2.5** The buckle shall be tested for strength in conformity with 6.2.1 under a load of 980 daN; the buckle shall neither break, nor be seriously distorted nor become detached.

### 5.3 Adjusting devices

**5.3.1** Two samples of each belt-adjusting device shall be tested for micro-slipping in accordance with 6.3.1.

The strap slip shall not exceed 25 mm per strap between the anchorage and the buckle.

**5.3.2** All the adjusting devices shall be tested for strength in accordance with 6.3.2 under a load of 980 daN. They shall neither break nor become detached. Where the adjusting device is part of the attachment, the load shall be increased to 1 470 daN.

### 5.4 Attachments

The attachments shall be tested for strength in accordance with 6.4 under a load of 1 470 daN. They shall neither break nor become detached. However for the crotch strap attachments

1) The rotation motion for the opening is required in order to optimize the efficiency of the emergency services although other safe and efficient solutions exist.

the load shall be reduced to 720 daN. In the case of a single attachment for the two crotch straps, this load shall be equal to the sum of the loads specified for testing the individual straps.

## 5.5 Metal parts

All the metal parts of a harness shall be suitably protected against corrosion.

After undergoing the corrosion test in 6.6, neither signs of deterioration likely to impair the proper functioning of the device nor any significant corrosion shall be visible to the unaided eye of a qualified observer.

## 5.6 Harness

**5.6.1** The harness shall be submitted to the dynamic test in 6.5.1.

During the test the following conditions shall be met:

- a) no part of the assembly affecting the restraint of the occupant of the vehicle shall break and no buckle or adjustment device shall unlock;
- b) the forward displacement of the manikin shall not be more than 200 mm at pelvic level and 300 mm at sternum level. (These displacements are in relation to the measurement points shown in figure B.6 in annex B.)

**5.6.2** After the assembly has been dynamically tested as in 6.5.1 and the buckle has been opened as in 6.2.2, it shall be possible, under a load of 75 daN perpendicular to the longitudinal axis of the manikin and contained in its symmetrical plane, to extract the manikin from the seat as described in 6.5.2. This load shall be applied approximately in the body centre.

## 5.7 Combustibility

The speed of combustion of the components of an assembly excepting the homologation label, buckle, adjusting devices, attachments and all metal parts, measured in conformity with 6.7, shall be less than or equal to 75 mm/min.

Materials which break down at relatively low temperatures to give off irritant toxic or corrosive fumes shall be avoided. Particular attention shall be paid to foam spreader pads.

## 6 Test methods

### 6.1 Strap breaking test

#### 6.1.1 Conditioning

The strap shall be conditioned before testing, for 24 h at a temperature of  $(20 \pm 5)$  °C in an atmosphere of  $(65 \pm 5)$  % relative humidity. If the test is not to be carried out immediately

after conditioning, the test piece shall be placed in a tightly closed container until the start of the test. The breaking load shall be measured within 5 min of the removal of each test piece from the conditioning atmosphere or from the container.

#### 6.1.2 Test procedure

**6.1.2.1** The breaking test shall be made on two specimen straps, of sufficient length, each strap being gripped between the clamps of a tensile-test machine. The clamps shall be so designed as to avoid breakage of the strap at or near them. The clamp traverse speed shall be about 100 mm/min. The free length of the specimen between the machine clamps at the start of the test shall be  $(200 \pm 40)$  mm.

**6.1.2.2** When the load reaches 980 daN, the width of the strap shall be measured without stopping the machine.

**6.1.2.3** The tension shall then be increased until the strap breaks.

**6.1.2.4** If the strap slips or breaks at or within 10 mm of either of the clamps, the test shall be invalid: a new test shall be carried out on another specimen.

### 6.2 Buckle tests

#### 6.2.1 Strength test

The buckle shall be mounted on the tensile-test machine used for the tests in 6.1.2. The connection of the buckle to the clamps of the machine shall be made by the straps attached to the two diametrically opposed tongues of the lap belt. The load shall be brought to 980 daN.

If the service conducting the tests deems it necessary, it may verify the strength of the buckle using other diametrically opposed tongues.

#### 6.2.2 Release test

**6.2.2.1** After the test in 6.5.1, a load of 75 daN shall be applied to the manikin (see the description in annex B) in a direction perpendicular to the longitudinal axis of the manikin body and contained in its plane of symmetry, in order to load the harness. The torque required to open the harness shall be measured. This load shall be applied approximately in the body centre.

**6.2.2.2** The torque required to open the buckle shall be applied by means of a measuring device, in the normal direction of opening.

**6.2.2.3** The torque required to open the buckle shall be measured and any failure shall be noted.





### 6.3.2 Strength test

The adjusting device shall be mounted on the tensile-test machine used for the tests in 6.1.2. The connection of the adjusting device to the machine clamps shall be made by the straps fixed to the device. The load shall be brought to the level set.

### 6.4 Attachment strength test

The attachment is mounted on the machine used for the tests in 6.1.2. The connection of the attachment to the machine clamps shall be made on the side by the strap fixed to the attachment and on the other by the system intended for the vehicle anchorage point fitting. The load shall be brought to the level set.

### 6.5 Harness tests

#### 6.5.1 Dynamic test of harness

**6.5.1.1** The harness shall be fitted to a trolley equipped with the seat and providing the anchorages described in annex A. However, for special cases the distances between the manikin and the anchorage shall be determined by the service conducting the tests, either in conformity with the instructions for fitting supplied with the harness or in conformity with the data supplied by the manufacturer of the vehicle.

**6.5.1.2** The harness shall be tightly fitted on the manikin.

**6.5.1.3** The trolley shall then be so propelled that at the moment of impact its free running speed is  $(50 \pm 1)$  km/h and the manikin remains stable. The stopping distance of the trolley shall be  $(400 \pm 50)$  mm. The trolley shall remain horizontal throughout deceleration. The deceleration curve of the trolley shall be as described in annex C.

#### 6.5.2 Test for manikin release

Once the buckle-opening test in 6.2.2 has been carried out, without touching the harness, a strap is passed around the

manikin body. The force required to extract the manikin from the seat shall then be measured.

### 6.6 Corrosion test

#### 6.6.1 Test chamber exposure

All the metal parts of a harness shall be positioned in a test chamber, to be submitted to a corrosion test as set in annex D. Except for short interruptions that may be necessary, for example to check and replenish the sodium chloride solution, the exposure test shall proceed continuously for a period of 50 h.

#### 6.6.2 Washing, drying and inspection

To complete the exposure test, the metal parts shall be gently washed, or dipped in clean running water with a temperature not higher than  $38^{\circ}\text{C}$  to remove any deposit that may have formed and then allowed to dry at room temperature for 24 h before inspection in accordance with 5.5.

### 6.7 Combustibility test of components

The specimens shall be tested for combustibility in accordance with ISO 3795.

## 7 Marking

### 7.1 Requirements

Every harness which conforms to a type meeting the requirements of this International Standard shall be marked according to annex E.

### 7.2 Method

The marking set in 7.1 shall be fixed in such a way that it is legible and indelible, either on a label or directly marked on the harness. Either the label or direct marking shall withstand normal wear and tear.

## Annex A (normative)

### Description of trolley, seat, anchorages and stopping device

#### A.1 Trolley

The mass of the trolley, supporting the seat alone, shall be  $(400 \pm 20)$  kg.

#### A.2 Seat

The seat shall be of rigid construction and have a smooth surface. The indications of figure A.1 shall be respected, ensuring that no metal parts may come into contact with the harness.

#### A.3 Anchorages

The anchorages shall be positioned in accordance with the indications in figure A.1. The points which correspond to the anchorage positions indicate the position of harness end attachments on the trolley. The structure bearing the anchorage shall be rigid and the trolley shall be built so as to prevent any permanent warping occurring in the parts providing the anchorages during the test.

#### A.4 Stopping device

The stopping device comprises two identical absorbers fitted parallel to each other. Each absorber is made up of

- an envelope in the form of a steel tube;
- an energy-absorbing tube in polyurethane;
- an oval knob in polished steel penetrating into the absorber and screwed on to the end of a shaft.

The dimensions of the various parts of this absorber are indicated in figures A.2 to A.4. The characteristics of the absorbent material are specified in table A.1.

Before the test, the tubes shall be maintained at a temperature of  $(20 \pm 5)$  °C for at least 12 h.

The requirements to be met by the stopping device are defined by the deceleration curve of the trolley shown in annex C. Any other device giving equivalent results may be accepted.

Dimensions in millimetres

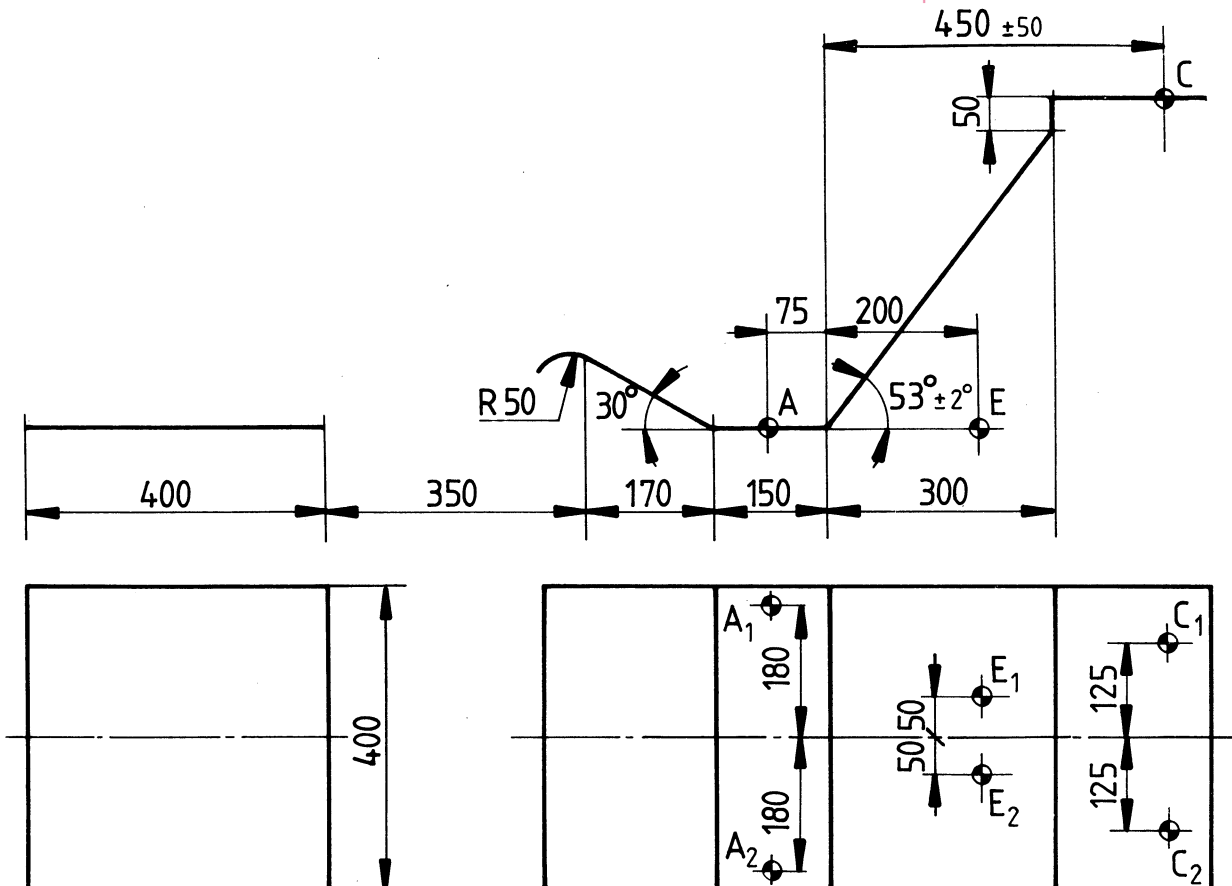

Figure A.1 — Seat dimensions and anchorage points

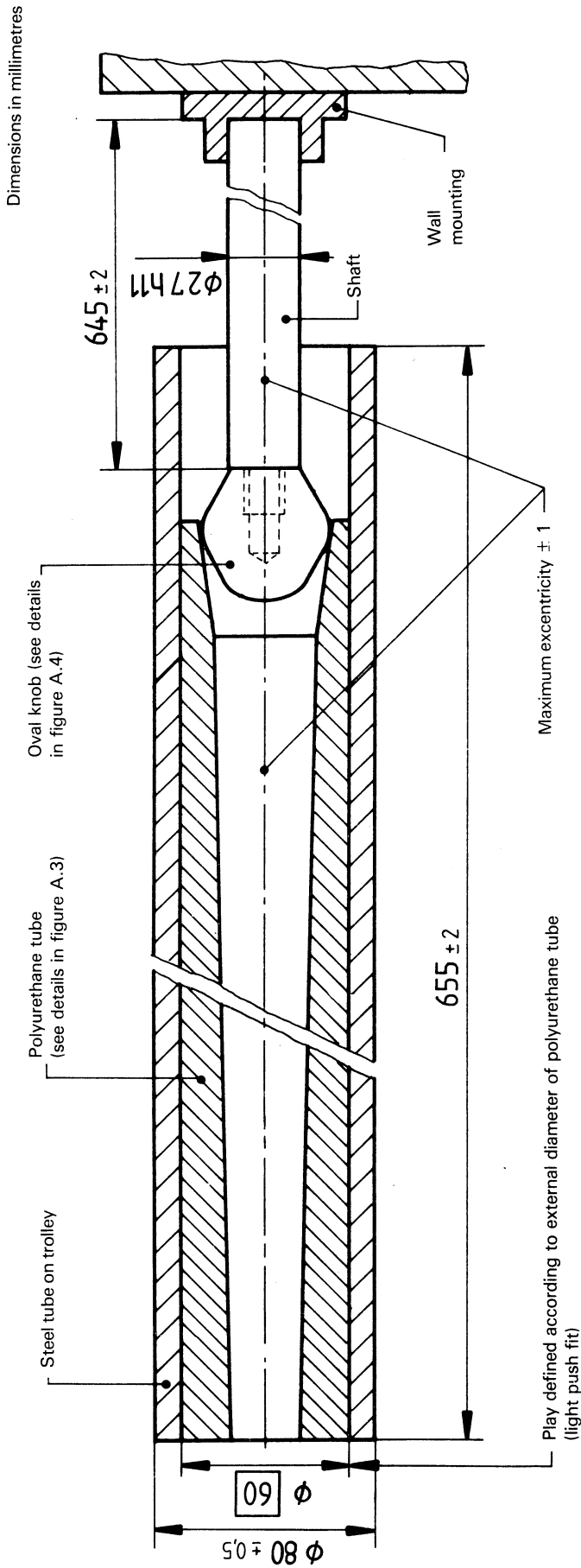

Figure A.2 — Stopping device — Dimensions and characteristics

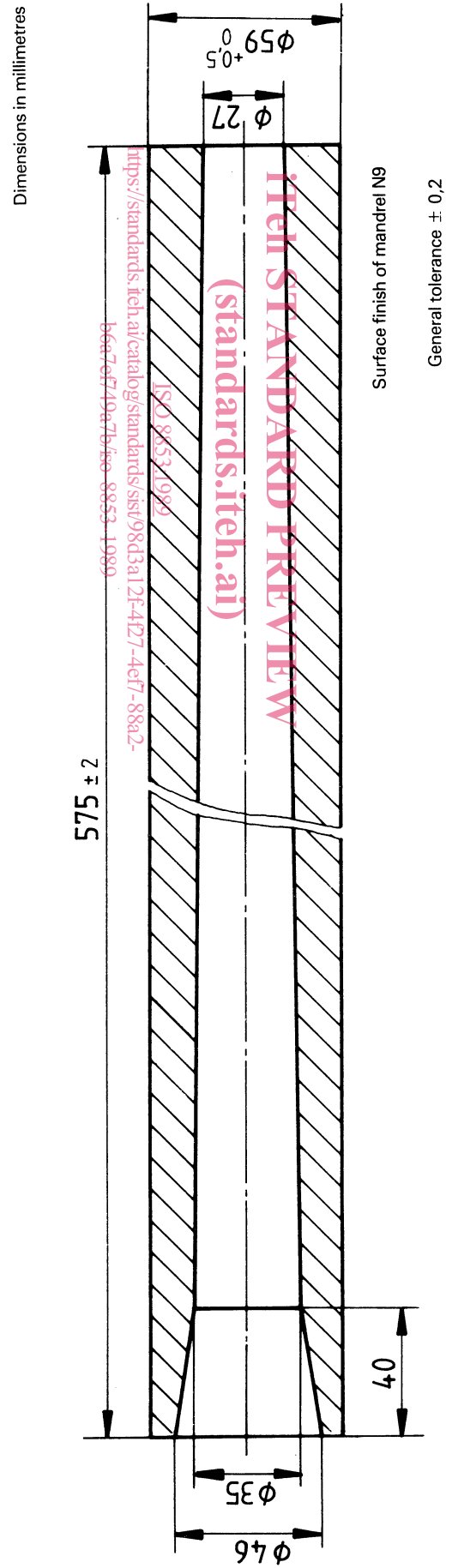

Figure A.3 — Stopping device — Details of polyurethane tube