Aerospace series - Bolts, normal hexagonal head, threaded to head, in corrosion resisting steel, passivated - Classification: 600 MPa (at ambient temperature) / 425 °C

Aerospace series - Bolts, normal hexagonal head, threaded to head, in corrosion resisting steel, passivated - Classification: 600 MPa (at ambient temperature) / 425 °C

Luft- und Raumfahrt - Sechskantschrauben, Gewinde annähernd bis Kopf, aus korrosionsbeständigem Stahl, passiviert - Klasse: 600 MPa (bei Raumtemperatur) / 425 °C

Série aérospatiale - Vis à tête hexagonale normale, filetées jusqu'à proximité de la tête, en acier résistant à la corrosion, passivées - Classification: 600 MPa (à température ambiante) / 425 °C

Ta slovenski standard je istoveten z: EN 2887:1995

ICS:

49.030.20 Sorniki, vijaki, stebelni vijaki Bolts, screws, studs

SIST EN 2887:2001

en

iTeh STANDARD PREVIEW
(standards.iteh.ai)

SIST EN 2887:2001

<https://standards.iteh.ai/catalog/standards/sist/867e90c3-4972-49a3-aa80-ebdf97947ae2/sist-en-2887-2001>

EUROPEAN STANDARD

EN 2887

NORME EUROPÉENNE

EUROPÄISCHE NORM

June 1995

ICS 49.040.20

Descriptors: aircraft industry, aircraft equipment, screw, hexagonal head screw, corrosion resistant steel, screw thread, specification, characteristic, dimension, mass, dimensional tolerance, surface treatment, designation, marking

English version

**Aerospace series - Bolts, normal hexagonal head,
threaded to head, in corrosion resisting steel,
passivated - Classification: 600 MPa (at ambient
temperature) / 425 °C**

Série aérospatiale - Vis à tête hexagonale normale, filetées jusqu'à proximité de la tête, en acier résistant à la corrosion, passivées - Classification: 600 MPa (à température ambiante) / 425 °C

Luft- und Raumfahrt - Sechskantschrauben, Gewinde annähernd bis Kopf, aus korrosionsbeständigem Stahl, passiviert - Klasse: 600 MPa (bei Raumtemperatur) / 425 °C

SIST EN 2887:2001

<https://standards.iteh.ai/catalog/standards/sist/867e90c3-4972-49a3-aa80-ebdf97947ae2/sist-en-2887-2001>

This European Standard was approved by CEN on 1995-06-07. CEN members are bound to comply with the CEN/CENELEC Internal Regulations which stipulate the conditions for giving this European Standard the status of a national standard without any alteration.

Up-to-date lists and bibliographical references concerning such national standards may be obtained on application to the Central Secretariat or to any CEN member.

The European Standards exist in three official versions (English, French, German). A version in any other language made by translation under the responsibility of a CEN member into its own language and notified to the Central Secretariat has the same status as the official versions.

CEN members are the national standards bodies of Austria, Belgium, Denmark, Finland, France, Germany, Greece, Iceland, Ireland, Italy, Luxembourg, Netherlands, Norway, Portugal, Spain, Sweden, Switzerland and United Kingdom.

CEN

European Committee for Standardization
Comité Européen de Normalisation
Europäisches Komitee für Normung

Central Secretariat: rue de Stassart, 36 B-1050 Brussels

© 1995

All rights of reproduction and communication in any form and by any means reserved in all countries to CEN and its members.

Ref. No. EN 2887:1995 E

Foreword

This European Standard has been prepared by the European Association of Aerospace Manufacturers (AECMA).

After inquiries and votes carried out in accordance with the rules of this Association, this Standard has successively received the approval of the National Associations and the Official Services of the member countries of AECMA, prior to its presentation to CEN.

This standard was submitted for Formal Vote, and the result was positive.

This European Standard shall be given the status of a national standard, either by publication of an identical text or by endorsement, at the latest by December 1995, and conflicting national standards shall be withdrawn at the latest by December 1995.

According to the CEN/CENELEC Internal Regulations, the following countries are bound to implement this European Standard:

Austria, Belgium, Denmark, Finland, France, Germany, Greece, Iceland, Ireland, Italy, Luxembourg, Netherlands, Norway, Portugal, Spain, Sweden, Switzerland, United Kingdom.

<https://standards.iteh.ai/catalog/standards/sist/067e90c3-4972-49a3-aa80-ebd17947ac2/sist-en-2887-2001>

INTERNATIONAL NORM OF TECHNICAL

1 Scope

This standard specifies the characteristics of bolts, normal hexagonal head, threaded to head, in corrosion resisting steel, passivated.

Classification : 600 MPa ¹⁾ / 425 °C ²⁾

2 Normative references

This European Standard incorporates by dated or undated reference provisions from other publications. These normative references are cited at the appropriate places in the text and the publications are listed hereafter. For dated references, subsequent amendments to or revisions of any of these publications apply to this European Standard only when incorporated in it by amendment or revision. For undated references the latest edition of the publication referred to applies.

- | | |
|------------|---|
| ISO 3353 | Aerospace - Rolled threads for bolts - Lead and runout requirements |
| ISO 5855-2 | Aerospace - MJ threads - Part 2 : Limit dimensions for bolts and nuts |
| ISO 7913 | Aerospace - Bolts and screws, metric - Tolerances of form and position |
| ISO 8168 | Aerospace - Corrosion- and heat-resisting steel bolts with strength classification 1 100 MPa and MJ threads - Procurement specification |
| EN 2000 | Aerospace series - Quality assurance EN aerospace products - Approval of the quality system of manufacturers |
| EN 2424 | Aerospace series - Marking of aerospace products |
| EN 2516 | Aerospace series - Passivation of corrosion resistant steels and decontamination of nickel base alloys ³⁾ |
| TR 3775 | Aerospace series - Bolts and pins - National materials ⁴⁾ |

1) Minimum tensile strength of the material at ambient temperature

2) Maximum temperature that the bolt can withstand without continuous change in its original characteristics, after return to ambient temperature. The maximum temperature is determined by the material.

3) In preparation at the date of publication of this standard

4) Published as AECMA Technical Report at the date of publication of this standard

3 Required characteristics

3.1 Configuration - Dimensions - Masses

See figure 1 and table 1.

Dimensions and tolerances are expressed in millimetres and apply after surface treatment.

Details of form not stated are left to the manufacturer's discretion.

3.2 Tolerances of form and position

ISO 7913

3.3 Materials

TR 3775 (corrosion resisting steel, classification 600 MPa)

3.4 Surface treatment

EN 2516

iTeh STANDARD PREVIEW
(standards.iteh.ai)

[SIST EN 2887:2001](https://standards.iteh.ai/catalog/standards/sist/867e90c3-4972-49a3-aa80-ebd97947ae2/sist-en-2887-2001)

<https://standards.iteh.ai/catalog/standards/sist/867e90c3-4972-49a3-aa80-ebd97947ae2/sist-en-2887-2001>

$3,2 \sqrt{\quad} \left[\begin{array}{c} 0,8 \\ \sqrt{\quad} \end{array} \right]$ Values in micrometres apply prior to surface treatment.

Break sharp edges 0,1 to 0,4

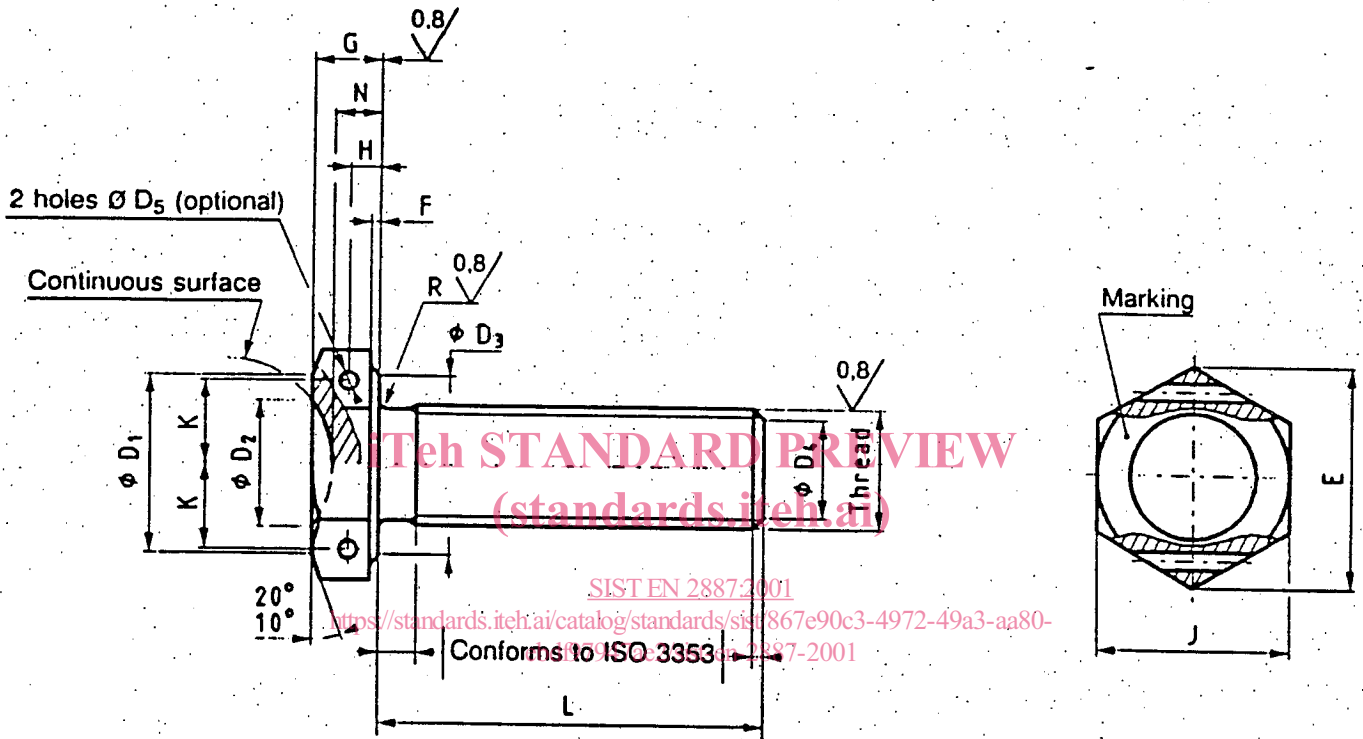

Figure 1

Table 1

Diameter code	Thread ¹⁾	D_1	D_2	D_3 ²⁾	D_4		D_5	E	F		G						
		min.	0 - 0,5	min.	nom.	Tol.	H13	min.	max.	min.	0 - 0,3						
030	MJ3x0,5 - 4h6h	5,5	—	5,4	2,3	0	—	6,5	0,4	0,5	0,2	2					
040	MJ4x0,7 - 4h6h	6,4	—	6,4	3	- 0,5	—	7,6	0,5			0,2	2,5				
050	MJ5x0,8 - 4h6h	7,4	5,25	7,4	3,4	± 0,5	1	8,7					0,5	0,2	3		
060	MJ6x1 - 4h6h	9,4	6,25	9,3	4,2		1,4	10,9							0,5	0,2	3,5
070	MJ7x1 - 4h6h	10,3	7,25	10,2	5,2			12									14,3
080	MJ8x1 - 4h6h	12,3	8,25	12,2	6,2		1,6	18,9	0,6	0,3	4,5						
100	MJ10x1,25 - 4h6h	16,3	10,25	16	7,9			21,1			24,5	5					
120	MJ12x1,25 - 4h6h	18,3	12,25	18	9,8	26,8		30,2			6						
140	MJ14x1,5 - 4h6h	21,3	14,25	21	11,5	33,6		—			7						
160	MJ16x1,5 - 4h6h	23,3	16,25	23	13,5	± 0,5	1,6	0,6	0,3	8							
180	MJ18x1,5 - 4h6h	26,3	18,25	26	15,5					9							
200	MJ20x1,5 - 4h6h	29,3	20,25	29	17,5					10							

(concluded)

Diameter code	H	J		K	$L \pm 0,3$ ^{3) 4)}		N 0 - 0,3	R		Mass ⁵⁾	
		nom.	Tol.		Code	nom.		max.	min.	6)	7)
030	—	6	h12	—	004 to 042	4 to 42	—	0,4	0,2	0,59	0,09
040	—	7		—	006 to 056	6 to 56	—			1,17	0,15
050	1,35	8		3,25	008 to 070	8 to 70	2	0,5	0,3	2	0,25
060	1,6	10	4,1	010 to 084	10 to 84	2,3	0,7	0,5	3,63	0,36	
070	1,85	11	4,5	010 to 098	10 to 98	2,7			5,1	0,5	
080	2,1	13	5,35	010 to 112	10 to 112	3	h13	0,6	7,59	0,67	
100	2,35	17	7,1	014 to 140	14 to 140	3,4			0,8	15,55	1,04
120	2,85	19	7,9	016 to 168	16 to 168	4			0,9	24,76	1,54
140	3,35	22	9,2	018 to 196	18 to 196	4,7	1,1	0,8	38,36	2,09	
160	3,85	24	10,05	020 to 224	20 to 224	5,4			54,55	2,79	
180	4,35	27	11,3	022 to 252	22 to 252	6	1,3	1	77,70	3,58	
200	4,85	30	12,6	022 to 280	22 to 280	6,7			102,24	4,46	

1) In accordance with ISO 5855-2

2) D_3 max. shall be less than J .

3) Increments :

2 for $L \leq 100$ 4 for $L > 100$ 4) If greater lengths are required, they shall be chosen using the above increments. The length code corresponds to the length L , completed by one or two zeros to the left, where necessary, to obtain a three digit code.5) Approximate values (kg/1 000 pieces), calculated on the basis of $7,85 \text{ kg/dm}^3$, given for information purposes only. They apply to bolts without holes.6) Value for head and first L 7) Increase for each additional 2 mm of L .