



SLOVENSKI STANDARD  
SIST EN 2985:2001  
01-januar-2001

**Aerospace series - Nickel-cadmium batteries of format A type**

Aerospace series - Nickel-cadmium batteries of format A type

Luft- und Raumfahrt - Nickel-Cadmium-Batterien - Bauart der Größenausführung A

Série aérospatiale - Batteries d'accumulateurs au nickel-cadmium du type de format A

ITEN STANDARD PREVIEW  
(standards.iteh.ai)

Ta slovenski standard je istoveten z: EN 2985:1996

SIST EN 2985:2001

<https://standards.iteh.ai/catalog/standards/sist/d925192e-952d-4008-84a0-ef33b30fcb2f/sist-en-2985-2001>

**ICS:**

49.060 Štejni sistemski napajalniki in oprema za letalstvo  
Aerospace electric equipment and systems

**SIST EN 2985:2001**

**en**

**iTeh STANDARD PREVIEW**  
**(standards.iteh.ai)**

SIST EN 2985:2001

<https://standards.iteh.ai/catalog/standards/sist/d925192e-952d-4008-84a0-e33b30fcb2f/sist-en-2985-2001>

EUROPEAN STANDARD

EN 2985

NORME EUROPÉENNE

EUROPÄISCHE NORM

July 1996

ICS 49.060

Descriptors: aircraft industry, aircraft equipment, electric batteries, storage batteries, nickel cadmium batteries, specifications, dimensions

English version

## Aerospace series - Nickel-cadmium batteries of format A type

Série aérospatiale - Batteries d'accumulateurs au nickel-cadmium du type de format A

Luft- und Raumfahrt - Nickel-Cadmium-Batterien - Bauart der Größenausführung A

STANDARD PREVIEW  
(standards.iteh.ai)

[SIST EN 2985:2001](https://standards.iteh.ai/catalog/standards/sist/d925192e-952d-4008-84a0-e33b30fcb2/sist-en-2985-2001)

<https://standards.iteh.ai/catalog/standards/sist/d925192e-952d-4008-84a0-e33b30fcb2/sist-en-2985-2001>

This European Standard was approved by CEN on 1995-06-29. CEN members are bound to comply with the CEN/CENELEC Internal Regulations which stipulate the conditions for giving this European Standard the status of a national standard without any alteration.

Up-to-date lists and bibliographical references concerning such national standards may be obtained on application to the Central Secretariat or to any CEN member.

The European Standards exist in three official versions (English, French, German). A version in any other language made by translation under the responsibility of a CEN member into its own language and notified to the Central Secretariat has the same status as the official versions.

CEN members are the national standards bodies of Austria, Belgium, Denmark, Finland, France, Germany, Greece, Iceland, Ireland, Italy, Luxembourg, Netherlands, Norway, Portugal, Spain, Sweden, Switzerland and United Kingdom.

# CEN

European Committee for Standardization  
Comité Européen de Normalisation  
Europäisches Komitee für Normung

Central Secretariat: rue de Stassart, 36 B-1050 Brussels

Page 2  
EN 2985 : 1996

**Foreword**

This European Standard has been prepared by the European Association of Aerospace Manufacturers (AECMA).

After inquiries and votes carried out in accordance with the rules of this Association, this Standard has received the approval of the National Associations and the Official Services of the member countries of AECMA, prior to its presentation to CEN.

This European Standard shall be given the status of a national standard, either by publication of an identical text or by endorsement, at the latest by January 1997 and conflicting national standards shall be withdrawn at the latest by January 1997.

According to the CEN/CENELEC Internal Regulations, the national standards organizations of the following countries are bound to implement this European Standard: Austria, Belgium, Denmark, Finland, France, Germany, Greece, Iceland, Ireland, Italy, Luxembourg, Netherlands, Norway, Portugal, Spain, Sweden, Switzerland and the United Kingdom.

**iTeh STANDARD PREVIEW**  
**(standards.iteh.ai)**

SIST EN 2985:2001

<https://standards.iteh.ai/catalog/standards/sist/492519e-952d-4008-84a0-03360e827e81/sist-en-2985-2001>

opublikacija in opredelitevica za EN broj  
ADVAL 2001

.....T010  
LJUBLJANSKI INŠTITUT ZA TESTIRANJE

01-1-73-



## 1 Scope

This standard specifies the characteristics of nickel-cadmium batteries of format A type.

NOTE : Format A type makes it possible to differentiate between the title of the present standard and those of the other product standards for nickel-cadmium batteries.

## 2 Normative references

This European Standard incorporates by dated or undated reference provisions from other publications. These normative references are cited at the appropriate places in the text and the publications are listed hereafter. For dated references, subsequent amendments to or revisions of any of these publications apply to this European Standard only when incorporated in it by amendment or revision. For undated references the latest edition of the publication referred to applies.

EN 2570 Aerospace series - Nickel-cadmium batteries - Technical specification

## 3 Characteristics

### 3.1 Dimensions

See figure 1.

Dimensions and tolerances are in millimetres.

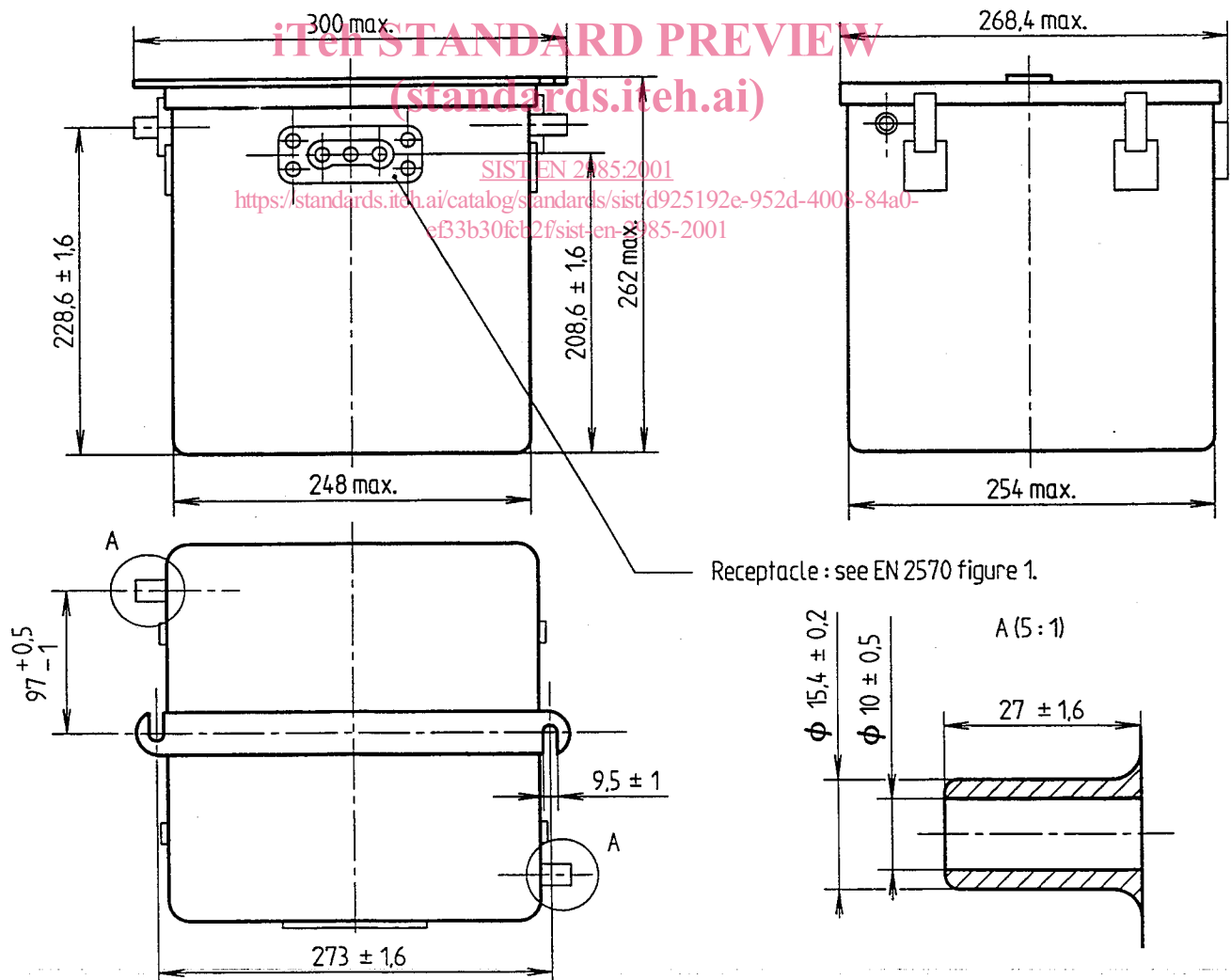

Figure 1

## 3.2 Physical characteristics

See table 1.

Table 1

Characteristics	Requirements
Mass (with accessories) Accessories 1)	40 kg max.
Marking	See 5.
Acceleration	See EN 2570 (for crash no ignition).
Electrolyte spillage	See EN 2570.
Seal of lid 1)	See EN 2570.
Minimum air flow rate of ventilation	0,027 m <sup>3</sup> /min
Resistance to salt spray	See EN 2570.
1) Verify if required by the designation.	

## 3.3 Electrical characteristics

See table 2.

## iTech STANDARD PREVIEW

Table 2

Characteristics	Test conditions	Requirements	
		Batteries	
		Normal	High power
Rated capacity $C_1$	-	34 Ah	34 Ah
Number of cells	-	According to code 1) 1 to 4	According to code 1) 5 to 7
Rated voltage		1,2 V per cell	
Available capacities	See EN 2570.	See EN 2570.	
Charge at - 18 °C	See EN 2570. 30 min 1 h 3 h	As % of $C_1$ Ah 4 to 6 8 to 12 15 to 20	
Charge recovered in 30 min	See EN 2570. 23 °C 50 °C	% of recharged capability 70   70 72   72	
Prolonged charge at high temperature	See EN 2570.	See EN 2570.	
Starting capability	Temperature $I$ at the 10th s $I$ from the 11th to the 30th s $U$ at the 15th s	See EN 2570. 5 $C_1$ A   10 $C_1$ A 2) 14 V   14 V	
Endurance	See EN 2570.	5 $C_1$ A   10 $C_1$ A	
Short-circuit	See EN 2570.	$I$ min. : 1 200 A $U$ min. : 2,5 V	
1) See table 3.			
2) Value fixed by the manufacturer			

## 4 Designation

EXAMPLE :

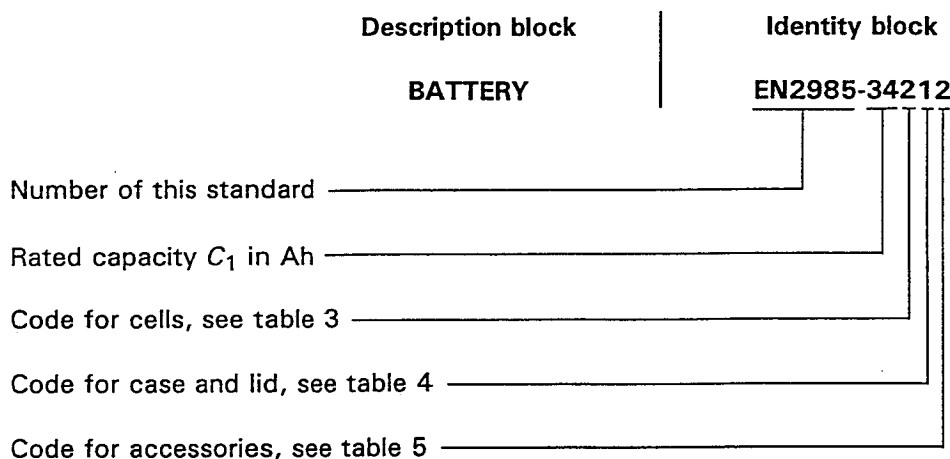

NOTE : If necessary, the code I9005 shall be placed between the description block and the identity block.

## iTeh STANDARD PREVIEW (standards.iteh.ai)

**Table 3**

Code	Cells		Electrolyte
	Number	Power	
1	20	Normal	Normal
2	19		Normal
3	20		Reserve
4	10		Normal
5	20	High	Normal
6	19		Normal
7	20		Reserve

**Table 4**

Code	Case and lid
1	Sealed lid
2	Code 1 + forced ventilation
3	Code 1 + aerobatic flights
4	Lid not sealed
5	Apertures in case and lid

**Table 5**

Code	Accessories
1	No accessories
2	With handles
3	With temperature sensor
4	With temperature sensor and handles

## 5 Marking

In addition to the identity block (see 4), each battery shall bear the following information :

- provisioning number (for military aircraft only);
- name of manufacturer;
- manufacturer's reference;
- country and location of manufacture;
- modification index where applicable;
- serial number;
- date of manufacture (month, year or code);
- safety instructions;
- polarity (see EN 2570);
- nominal voltage;
- rated capacity;
- number of cells.

**iTeh STANDARD PREVIEW**  
**(standards.iteh.ai)**

Unless otherwise indicated, the position of these markings is left to the manufacturer's discretion.

<https://standards.iteh.ai/catalog/standards/sist/d925192e-952d-4008-84a0-ef33b30fcb2f/sist-en-2985-2001>

## 6 Log book

It shall contain the information of 5, information required by EN 2570 and that concerning any special particulars.

## 7 Technical specification

EN 2570