

**SLOVENSKI STANDARD**  
**SIST EN 3037:2001****01-januar-2001**

---

**Aerospace series - Screws, pan head, offset cruciform recess, close tolerance normal shank, short thread, in titanium alloy, anodized, MoS2 lubricated - Classification: 1 100 MPa (at ambient temperature)/315°C**

Aerospace series - Screws, pan head, offset cruciform recess, close tolerance normal shank, short thread, in titanium alloy, anodized, MoS2 lubricated - Classification: 1 100 MPa (at ambient temperature)/315 °C

Luft- und Raumfahrt - Flachkopf-Paßschrauben mit Flügelkreuzschlitz, kurzes Gewinde, aus Titanlegierung, anodisiert, MoS2-geschmiert - Klasse 1 100 MPa (bei Raumtemperatur)/315 °C

[SIST EN 3037:2001](https://standards.iteh.ai/catalog/standards/sist/b32e7ce9-e5af-4716-8a06-)

Série aérospatiale - Vis à tete cylindrique, à empreinte cruciforme déportée, tige normale à tolérance serrée, filetage court, en alliage de titane, anodisées, lubrifiées MoS2 - Classification: 1 100 MPa (à température ambiante)/315 °C

**Ta slovenski standard je istoveten z: EN 3037:1996**

---

**ICS:**

49.030.20 Sorniki, vijaki, stebelni vijaki Bolts, screws, studs

**SIST EN 3037:2001****en**

**iTeh STANDARD PREVIEW**  
**(standards.iteh.ai)**

[SIST EN 3037:2001](#)

<https://standards.iteh.ai/catalog/standards/sist/b32e7ce9-e5af-4716-8a06-37af1be821a8/sist-en-3037-2001>

EUROPEAN STANDARD

EN 3037

NORME EUROPÉENNE

EUROPÄISCHE NORM

September 1996

ICS 49.040.20

Descriptors: aircraft industry, screw, cheese head screw, cross recessed screw, titanium alloy, specification, dimension, dimensional tolerance, surface treatment, designation, marking

English version

**Aerospace series - Screws, pan head, offset cruciform recess, close tolerance normal shank, short thread, in titanium alloy, anodized; MoS<sub>2</sub> lubricated - Classification: 1 100 MPa (at ambient temperature)/315 °C**

iTech STANDARD PREVIEW

Série aéronautique - Vis à tête cylindrique, à empreinte cruciforme déportée, tige normale à tolérance serrée, filetage court, en alliage de titane, anodisées, lubrifiées MoS<sub>2</sub> - Classification: 1 100 MPa (à température ambiante)/315 °C

Luft- und Raumfahrt - Flachkopf-Paßschrauben mit Flügelkreuzschlitz, kurzes Gewinde, aus Titanlegierung, anodisiert, MoS<sub>2</sub> geschmiert - Klasse: 1 100 MPa (bei Raumtemperatur)/315 °C

SIST EN 3037:2001

<https://standards.iteh.ai/catalog/standards/sist/b32e7ce9-e5af-4716-8a06-37af1be821a8/sist-en-3037-2001>

This European Standard was approved by CEN on 1996-06-29. CEN members are bound to comply with the CEN/CENELEC Internal Regulations which stipulate the conditions for giving this European Standard the status of a national standard without any alteration.

Up-to-date lists and bibliographical references concerning such national standards may be obtained on application to the Central Secretariat or to any CEN member.

The European Standards exist in three official versions (English, French, German). A version in any other language made by translation under the responsibility of a CEN member into its own language and notified to the Central Secretariat has the same status as the official versions.

CEN members are the national standards bodies of Austria, Belgium, Denmark, Finland, France, Germany, Greece, Iceland, Ireland, Italy, Luxembourg, Netherlands, Norway, Portugal, Spain, Sweden, Switzerland and United Kingdom.

CEN

European Committee for Standardization  
Comité Européen de Normalisation  
Europäisches Komitee für Normung

Central Secretariat: rue de Stassart, 36 B-1050 Brussels

Page 2  
EN 3037:1996

## Foreword

This European Standard has been prepared by the European Association of Aerospace Manufacturers (AECMA).

After inquiries and votes carried out in accordance with the rules of this Association, this Standard has received the approval of the National Associations and the Official Services of the member countries of AECMA, prior to its presentation to CEN.

This European Standard shall be given the status of a national standard, either by publication of an identical text or by endorsement, at the latest by March 1997, and conflicting national standards shall be withdrawn at the latest by March 1997.

According to the CEN/CENELEC Internal Regulations, the national standards organizations of the following countries are bound to implement this European Standard: Austria, Belgium, Denmark, Finland, France, Germany, Greece, Iceland, Ireland, Italy, Luxembourg, Netherlands, Norway, Portugal, Spain, Sweden, Switzerland and the United Kingdom.



SIST EN 3037:2001

<https://standards.iteh.ai/catalog/standards/sist/682e33e9-e5af-4716-8a06-57a06c07436a/en-3037-2001>

57a06c07436a-en-3037-2001

development of standards in the field

AVIATION

.....T010

EVYKAZOVANÉ NEDĚLNÍ DNE

## 1 Scope

This standard specifies the characteristics of screws, pan head, offset cruciform recess, close tolerance normal shank, short thread, in titanium alloy, anodized, MoS<sub>2</sub> lubricated.

Classification : 1 100 MPa <sup>1)</sup> / 315 °C <sup>2)</sup>

## 2 Normative references

This European Standard incorporates by dated or undated reference provisions from other publications. These normative references are cited at the appropriate places in the text and the publications are listed hereafter. For dated references, subsequent amendments to or revisions of any of these publications apply to this European Standard only when incorporated in it by amendment or revision. For undated references the latest edition of the publication referred to applies.

ISO 3353	Aerospace - Rolled threads for bolts - Lead and runout requirements
ISO 5855-2	Aerospace - MJ threads - Part 2 : Limit dimensions for bolts and nuts
ISO 7913	Aerospace - Bolts and screws, metric - Tolerances of form and position
ISO 7994	Aerospace - Internal drive, offset cruciform recess (Torq-Set®) for rotary fastening devices - Metric series
ISO 9152	Aerospace - Titanium alloy bolts, strength class 1 100 MPa, MJ threads - Procurement specification <sup>3)</sup>
EN 2000	Aerospace series - Quality assurance - EN aerospace products - Approval of the quality system of manufacturers
EN 2424	Aerospace series - Marking of aerospace products
EN 2491	Aerospace series - Molybdenum disulphide dry lubricants - Coating methods <sup>4)</sup>
EN 3042	Aerospace series - Quality assurance - EN aerospace products - Qualification procedure
EN 4016	Aerospace series - Oversized bolts <sup>5)</sup>
TR 3775	Aerospace series - Bolts and pins - National materials <sup>6)</sup>
TR 4070	Aerospace series - Molybdenum disulphide dry lubricants - List of commercial products <sup>3)</sup>

1) Minimum tensile strength of the material at ambient temperature

2) Maximum temperature that the screw can withstand without continuous change in its original characteristics, after return to ambient temperature. The maximum temperature is determined by the surface treatment.

3) In preparation at the date of publication of this standard

4) Published as AECMA Standard at the date of publication of this standard

5) Published as AECMA Prestandard at the date of publication of this standard

6) Published as AECMA Technical Report at the date of publication of this standard

### 3 Required characteristics

#### 3.1 Configuration - Dimensions - Masses

See figure 1 and table 1.

Dimensions and tolerances are expressed in millimetres and apply after anodizing but before lubricating.

#### 3.2 Tolerances of form and position

ISO 7913

#### 3.3 Materials

TR 3775 (titanium alloy, strength class 1 100 MPa)

#### 3.4 Surface treatment

Lubrication :

- lubricant : see TR 4070
- application : EN 2491 : 5  $\mu\text{m}$  to 10  $\mu\text{m}$ .

**ITeh STANDARD PREVIEW**  
(standards.iteh.ai)  
<https://standards.iteh.ai/catalog/standards/sist/b32e7ce9-e5af-4716-8a06-37af1be821a8/sist-en-3037-2001>

3,2 / [ 0,8 ]

Values in micrometres apply prior to surface treatment.

Break sharp edges 0,1 to 0,4.

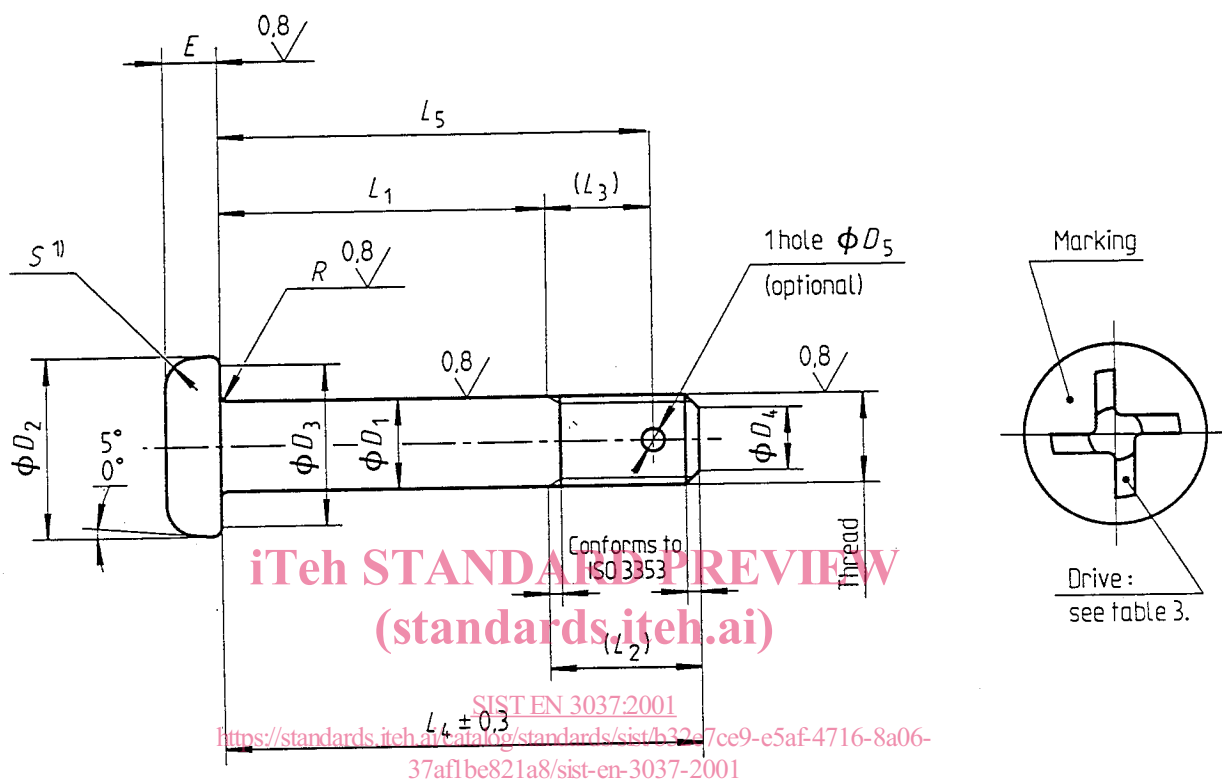

1) Shape optional

Figure 1

Table 1

Diameter code	Thread <sup>1)</sup>	$D_1$ f7	$D_2$ 0 - 0,3	$D_3$ min.	$D_4$		$D_5$ H13	$E$	
					nom.	Tol.		nom.	Tol.
030	MJ3x0,5 - 4h6h	3	6	4,7	2,3	0 - 0,5	—	1,8	0 - 0,2
040	MJ4x0,7 - 4h6h	4	8	6,7	3		1,1	2,4	
050	MJ5x0,8 - 4h6h	5	10	8,7	3,4	$\pm 0,5$	1,5	3	
060	MJ6x1 - 4h6h	6	12	10,7	4,2		3,6	0 - 0,3	
070	MJ7x1 - 4h6h	7	14	12,7	5,2		1,9		4,2
080	MJ8x1 - 4h6h	8	16	14,7	6,2		4,8		6
100	MJ10x1,25 - 4h6h	10	20	18,7	7,9		2,4	7,2	
120	MJ12x1,25 - 4h6h	12	24	22,7	9,8				

Diameter code	$L_1 \pm 0,2$ <sup>2) 3)</sup>		$L_2$	$L_3$	$R$		$S$		Mass <sup>4)</sup>	
	Code	nom.			nom.	Tol.	max.	min.	5)	6)
030	002 to 030	2 to 30	6	—	0,4	0	1,2	0,3	0,38	0,03
040	002 to 040	2 to 40	7,5	5			1,6	0,4	0,92	0,06
050	003 to 050	3 to 50	9	6	0,5	0,2	2	0,5	1,88	0,08
060	003 to 060	3 to 60	10	7	0,7		2,4	0,6	3,10	0,12
070	004 to 070	4 to 70	11	—	0,8	0	2,8	0,7	5,31	0,17
080	004 to 080	4 to 80	11,5	7,5			3,2	0,8	7,23	0,22
100	005 to 100	5 to 100	14,5	9	0,8	0 - 0,3	4	1	14,24	0,35
120	006 to 120	6 to 120	16	10	0,9		4,8	1,2	25,17	0,50

1) In accordance with ISO 5855-2, except the thread major diameter " $d$  max.", which shall be equal to  $D_1$  min. - 0,025.

2) Increments :

- 1 for  $L_1 \leq 30$
- 2 for  $30 < L_1 \leq 100$
- 4 for  $L_1 > 100$

3) If greater lengths are required, they shall be chosen using the above increments. The length code corresponds to the length  $L_1$ , completed by one or two zeros to the left, where necessary, to obtain a three digit code.

4) Approximate values (kg/1 000 pieces), calculated on the basis of 4,45 kg/dm<sup>3</sup>, given for information purposes only. They apply to screws without hole.

5) Value for head and first  $L_4$

6) Increase for each additional millimetre of  $L_4$ .



## 4 Designation

EXAMPLE :

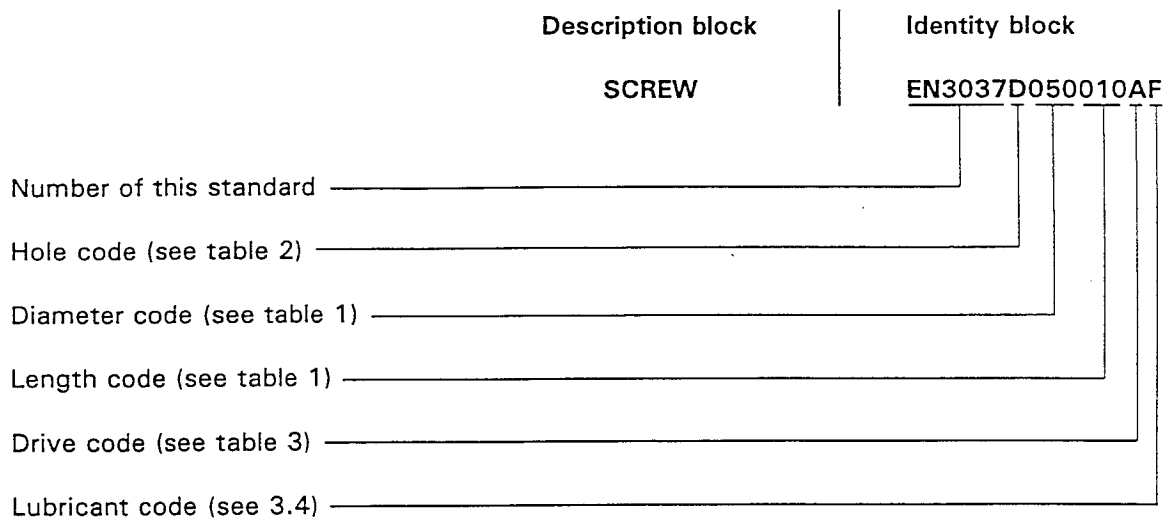

NOTE : If necessary, the code I9005 shall be placed between the description block and the identity block.

**iTeh STANDARD PREVIEW**  
(standards.iteh.ai)

Table 2

Hole	Code
with	D
without	— (hyphen)

Table 3

Drive	Code
ISO 7994	R
ISO 7994 unribbed	A

## 5 Marking

See table 4 and figure 1, indented.

Table 4

Diameter code	EN 2424 Style
030 and 040	N
050 to 120	C + MJ