



SLOVENSKI STANDARD SIST EN 60745-2-5:2007

01-november-2007

BUXca Yý U

SIST EN 60745-2-5:2003

SIST EN 60745-2-5:2003/OprA2:2004

9`Y_f] bUfc bUfcX^U!`JUfbcgh!`&!) "XY.`DcgYVbY`nU hYj Y`nU`fcybY`yU` Y`f!97
* \$+() !&!) .&\$ \$* žgdfYa Yb^YbŁ

Hand-held motor-operated electric tools - Safety -- Part 2-5: Particular requirements for circular saws

iTeh STANDARD PREVIEW

Handgeführte motorbetriebene Elektrowerkzeuge - Sicherheit -- Teil 2-5: Besondere Anforderungen für Kreissägen

[SIST EN 60745-2-5:2007](https://standards.iteh.ai/catalog/standards/sist/en-60745-2-5-2007)

Outils électroportatifs à moteur - Sécurité -- Partie 2-5: Règles particulières pour les scies circulaires

Ta slovenski standard je istoveten z: EN 60745-2-5:2007

ICS:

25.080.60	Strojne žage	Sawing machines
25.140.20	Ò\^ dā } æ\! àæ	Electric tools

SIST EN 60745-2-5:2007

en,fr,de

iTeh STANDARD PREVIEW
(standards.iteh.ai)

SIST EN 60745-2-5:2007

<https://standards.iteh.ai/catalog/standards/sist/ee94f51a-1e29-4381-b93c-31c54678f1bd/sist-en-60745-2-5-2007>

EUROPEAN STANDARD

EN 60745-2-5

NORME EUROPÉENNE

EUROPÄISCHE NORM

March 2007

ICS 25.140.20; 25.140.30

Supersedes EN 60745-2-5:2003

English version

**Hand-held motor-operated electric tools -
Safety -
Part 2-5: Particular requirements for circular saws
(IEC 60745-2-5:2006, modified)**

Outils électroportatifs à moteur -
Sécurité -
Partie 2-5: Règles particulières
pour les scies circulaires
(CEI 60745-2-5:2006, modifiée)

Handgeführte motorbetriebene
Elektrowerkzeuge -
Sicherheit -
Teil 2-5: Besondere Anforderungen
für Kreissägen
(IEC 60745-2-5:2006, modifiziert)

iTeh STANDARD PREVIEW
(standards.iteh.ai)

This European Standard was approved by CENELEC on 2006-11-01. CENELEC members are bound to comply with the CEN/CENELEC Internal Regulations which stipulate the conditions for giving this European Standard the status of a national standard without any alteration.

Up-to-date lists and bibliographical references concerning such national standards may be obtained on application to the Central Secretariat or to any CENELEC member.

This European Standard exists in three official versions (English, French, German). A version in any other language made by translation under the responsibility of a CENELEC member into its own language and notified to the Central Secretariat has the same status as the official versions.

CENELEC members are the national electrotechnical committees of Austria, Belgium, Bulgaria, Cyprus, the Czech Republic, Denmark, Estonia, Finland, France, Germany, Greece, Hungary, Iceland, Ireland, Italy, Latvia, Lithuania, Luxembourg, Malta, the Netherlands, Norway, Poland, Portugal, Romania, Slovakia, Slovenia, Spain, Sweden, Switzerland and the United Kingdom.

CENELEC

European Committee for Electrotechnical Standardization
Comité Européen de Normalisation Electrotechnique
Europäisches Komitee für Elektrotechnische Normung

Central Secretariat: rue de Stassart 35, B - 1050 Brussels

Foreword

The text of document 61F/643/FDIS, future edition 4 of IEC 60745-2-5, prepared by SC 61F, Safety of hand-held motor-operated electric tools, of IEC TC 61, Safety of household and similar electrical appliances, was submitted to the IEC-CENELEC parallel vote.

A draft amendment, prepared by the Technical Committee CENELEC TC 61F, Safety of hand-held and transportable motor-operated electric tools, to bring the European Standard in line with the essential health and safety requirements of the Machinery Directive, was submitted to the formal vote.

The combined texts were approved by CENELEC as EN 60745-2-5 on 2006-11-01.

This European Standard supersedes EN 60745-2-5:2003.

Main changes include: Clause 19: Mechanical hazards, clarifications in respect to the guarding; editorial modifications in Annex AA, the addition of Annex M: Safety of working stands for operation with hand-held motor-operated electric tools and editorial modifications to match with EN 60745-1:2006.

The following dates were fixed:

- latest date by which the EN has to be implemented at national level by publication of an identical national standard or by endorsement (dop) 2007-11-01
- latest date by which the national standards conflicting with the EN have to be withdrawn (dow) 2009-11-01

This standard is divided into two parts: <https://standards.iteh.ai/catalog/standards/sist/ee94f51a-1e29-4381-b93c-4c34678f1bd/sist-en-60745-2-5-2007>

Part 1: General requirements which are common to most hand-held electric motor operated tools (for the purpose of this standard referred to simply as tools) which could come within the scope of this standard;

Part 2: Requirements for particular types of tools which either supplement or modify the requirements given in Part 1 to account for the particular hazards and characteristics of these specific tools.

This European Standard has been prepared under a mandate given to CENELEC by the European Commission and the European Free Trade Association and covers essential health and safety requirements of EC Directive 98/37/EC, amended by EC Directive 98/79/EC. See Annex ZZ.

Compliance with the clauses of Part 1 together with this Part 2 provides one means of conforming with the essential health and safety requirements of the Directive concerned.

CEN/TC 255 is producing standards for non-electric circular saws (EN 792-12).

Warning: Other requirements and other EC Directives can be applicable to the products falling within the scope of this standard.

This standard follows the overall requirements of EN ISO 12100-1 and EN ISO 12100-2.

This Part 2-5 is to be used in conjunction with EN 60745-1:2006. When this standard states "addition", "modification" or "replacement", the relevant text in Part 1 is to be adapted accordingly.

Subclauses, tables and figures which are additional to those in Part 1 are numbered starting from 101; additional annexes are lettered AA, BB, etc.

Subclauses, tables and figures which are additional to those in IEC 60745-2-5:2006 are prefixed "Z".

Annexes ZA and ZZ have been added by CENELEC.

NOTE In this standard the following print types are used:

- requirements proper; in roman type
- *test specifications: in italic type;*
- explanatory matter: in smaller roman type.

iTeh STANDARD PREVIEW (standards.iteh.ai)

[SIST EN 60745-2-5:2007](https://standards.iteh.ai/catalog/standards/sist/ee94f51a-1e29-4381-b93c-31c54678f1bd/sist-en-60745-2-5-2007)

<https://standards.iteh.ai/catalog/standards/sist/ee94f51a-1e29-4381-b93c-31c54678f1bd/sist-en-60745-2-5-2007>

Endorsement notice

The text of the International Standard IEC 60745-2-5:2006 was approved by CENELEC as a European Standard with agreed common modifications as given below.

COMMON MODIFICATIONS

2 Normative references

Replace the text by:

This clause of Part 1 is applicable, except as follows:

Addition:

EN 847-1:1997, *Tools for woodworking - Safety requirements - Part 1: Milling tools and circular saw blades*

6 Void

Replace by:

6 Environmental requirements

This clause of Part 1 is applicable, except as follows:

6.1.2.4 *Modification:*

SIST EN 60745-2-5:2007
<https://standards.iteh.ai/catalog/standards/sist/ee94f51a-1e29-4381-b93c-31c54678f1bd/sist-en-60745-2-5-2007>

Circular saws are held and used as specified in 6.1.2.5.

6.1.2.5 *Modification:*

Circular saws are tested under load observing the conditions shown in Table Z101.

Table Z101 – Operating conditions for circular saws

Orientation	<p>Cutting a horizontal piece of chipboard with minimum dimensions 800 mm x 600 mm and a thickness depending on maximum cutting depth of the circular saw</p> <p>maximum cutting depth 40 mm: chipboard thickness 19 mm maximum cutting depth > 40 mm: chipboard thickness 38 mm</p> <p>The board shall be firmly fixed by screws or clamps to a test bench using resilient material. It shall be mounted so that it does not have any significant resonance in the frequency range that can influence the test result.</p> <p>The board excess end shall be 250 mm from the clamped area and shall be readjusted at the beginning of each series of tests.</p>
Tool bit	New blade as recommended by the manufacturer for cutting chipboard
Feed force	Just sufficient to cut at a brisk pace. Equal force shall be applied to both handles, if applicable. Excessive grip forces shall be avoided.
Test cycle	<p>One test cycle is given by cutting off one approximately 10 mm wide strip (set by rip fence if available) across the 600 mm width of the chipboard.</p> <p>The measurement starts when the blade enters the wood and finishes when the blade leaves the wood.</p>

6.2 Vibration

iTeh STANDARD PREVIEW

6.2.4.2 Location of measurement

(standards.iteh.ai)

Addition:

[SIST EN 60745-2-5:2007](https://standards.iteh.ai/catalog/standards/sist/ce94f51a-1e29-4381-b93c-31c3467811bd/sist-ce94f51a-1e29-4381-b93c-31c3467811bd/sist-en-60745-2-5-2007)

Figure Z101 shows the positions on the main handle and the auxiliary handle, if applicable.

6.2.6.3 Operating conditions

Addition:

Circular saws are tested under load observing the conditions shown in Table Z101.

6.2.7.2 Declaration of the vibration emission value

Addition:

The vibration emission value a_h of the handle with the highest emission and the uncertainty K shall be declared.

8 Marking and instructions

8.12.2 a) Add to the addition:

- Z101) Instruction on the correct use of the dust collection system
- Z102) Instruction to wear a dust mask
- Z103) Instruction to only use saw blades recommended
- Z104) Instruction to always wear hearing protection

8.12.2 b) Add to the addition:

Z101) Maximum cutting depth

19 Mechanical hazards

Add after 19.106:

19.Z101 The saw blade(s) delivered with the tool shall comply with EN 847-1.

Compliance is checked by inspection.

21 Construction

Add:

21.Z1 *Addition:*

Circular saws are considered to be tools where a considerable amount of dust is produced.

iTeh STANDARD PREVIEW
(standards.iteh.ai)

[SIST EN 60745-2-5:2007](https://standards.iteh.ai/catalog/standards/sist/ee94f51a-1e29-4381-b93c-31c54678f1bd/sist-en-60745-2-5-2007)

<https://standards.iteh.ai/catalog/standards/sist/ee94f51a-1e29-4381-b93c-31c54678f1bd/sist-en-60745-2-5-2007>

Add the following new figure:

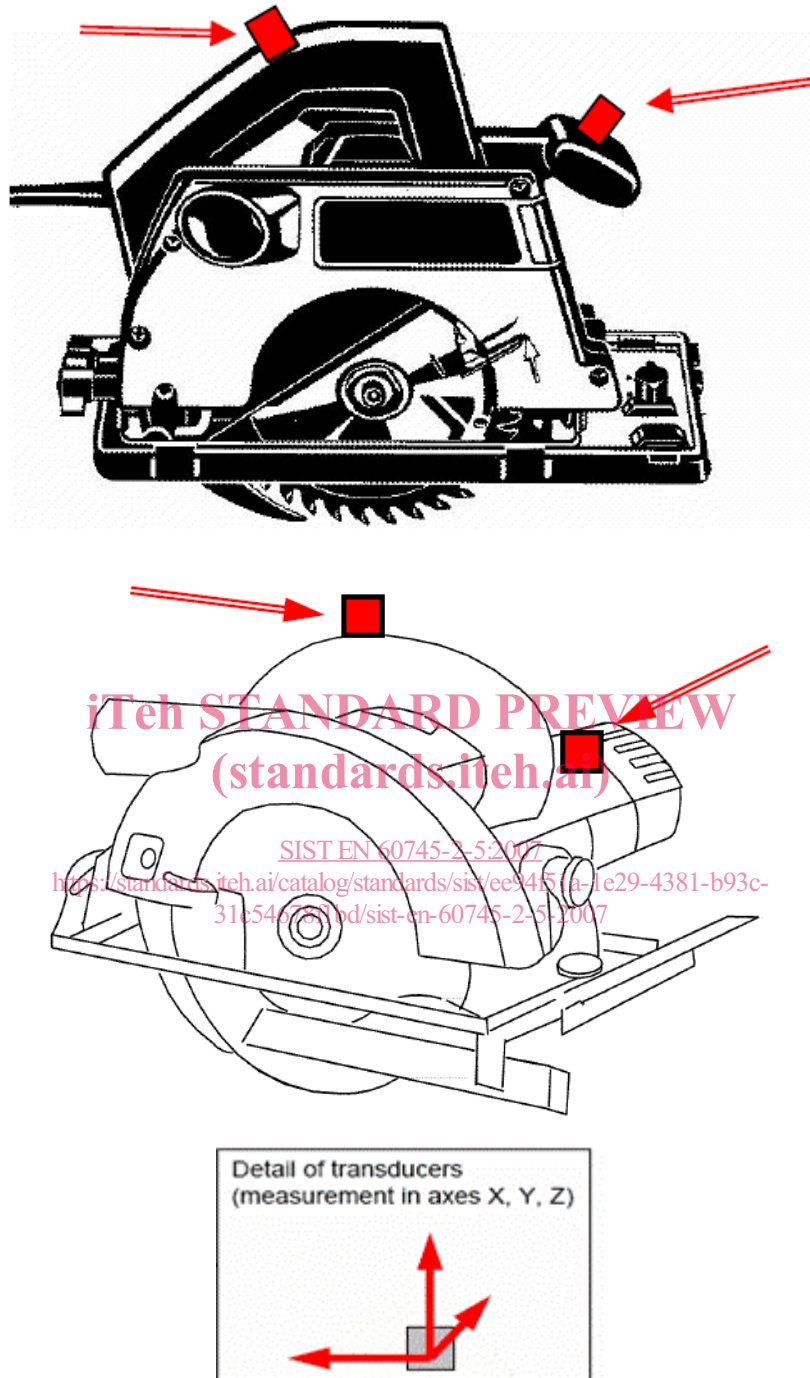

Figure Z101 – Positions of transducers for circular saws

Annex M (normative)

Safety of working stands for operation with hand-held motor-operated electric tools

M.19.1.302.2.3 *Replace the last paragraph by:*

- *For riving knife mounted saw blade guards, the guard shall be subjected to a load of 5 N at the front edge of the guard as defined in Figure M.302. The maximum deflection shall not be more than 15 mm.*
- *For separately from riving knife mounted saw blade guards, the guard shall be subjected to a load of 20 N at the front edge of the guard as defined in Figure M.302. The maximum deflection shall not be more than 8,0 mm.*

iTeh STANDARD PREVIEW
(standards.iteh.ai)

[SIST EN 60745-2-5:2007](https://standards.iteh.ai/catalog/standards/sist/ee94f51a-1e29-4381-b93c-31c54678f1bd/sist-en-60745-2-5-2007)

<https://standards.iteh.ai/catalog/standards/sist/ee94f51a-1e29-4381-b93c-31c54678f1bd/sist-en-60745-2-5-2007>

Add the following annexes:

**Annex ZA
(normative)**

**Normative references to international publications
with their corresponding European publications**

The following referenced documents are indispensable for the application of this document. For dated references, only the edition cited applies. For undated references, the latest edition of the referenced document (including any amendments) applies.

NOTE When an international publication has been modified by common modifications, indicated by (mod), the relevant EN/HD applies.

<u>Publication</u>	<u>Year</u>	<u>Title</u>	<u>EN/HD</u>	<u>Year</u>
–	–	Tools for woodworking - Safety requirements - Part 1: Milling tools and circular saw blades	EN 847-1	1997

iTeh STANDARD PREVIEW

**(standards.tch.ai)
Annex ZZ
(informative)**

[SIST EN 60745-2-5:2007](#)

Coverage of Essential Requirements of EC Directives

[31c54678f1bd/sist-en-60745-2-5-2007](#)

This European Standard has been prepared under a mandate given to CENELEC by the European Commission and the European Free Trade Association and within its scope the standard covers all relevant essential requirements as given in Annex I EC Directive 98/37/EC (Machinery Directive), amended by Directive 98/79/EC.

Compliance with this standard provides one means of conformity with the specified essential requirements of the Directives concerned.

WARNING: Other requirements and other EC Directives may be applicable to the products falling within the scope of this standard.

iTeh STANDARD PREVIEW
(standards.iteh.ai)

SIST EN 60745-2-5:2007

<https://standards.iteh.ai/catalog/standards/sist/ee94f51a-1e29-4381-b93c-31c54678f1bd/sist-en-60745-2-5-2007>

NORME
INTERNATIONALE
INTERNATIONAL
STANDARD

CEI
IEC

60745-2-5

Quatrième édition
Fourth edition
2006-07

**Outils électroportatifs à moteur –
Sécurité –**

**Partie 2-5:
Règles particulières pour
les scies circulaires**

iteh STANDARD PREVIEW

(standards.iteh.ai)

**Hand-held motor-operated electric tools –
Safety –**

[SIST EN 60745-2-5:2007
https://standards.iteh.ai/catalog/standards/sist/ee94f51a-1e29-4381-b93c-31c54678f1bd/sist-en-60745-2-5-2007](https://standards.iteh.ai/catalog/standards/sist/ee94f51a-1e29-4381-b93c-31c54678f1bd/sist-en-60745-2-5-2007)

Part 2-5:

Particular requirements for circular saws

© IEC 2006 Droits de reproduction réservés — Copyright - all rights reserved

Aucune partie de cette publication ne peut être reproduite ni utilisée sous quelque forme que ce soit et par aucun procédé, électronique ou mécanique, y compris la photocopie et les microfilms, sans l'accord écrit de l'éditeur.

No part of this publication may be reproduced or utilized in any form or by any means, electronic or mechanical, including photocopying and microfilm, without permission in writing from the publisher.

International Electrotechnical Commission, 3, rue de Varembe, PO Box 131, CH-1211 Geneva 20, Switzerland
Telephone: +41 22 919 02 11 Telefax: +41 22 919 03 00 E-mail: inmail@iec.ch Web: www.iec.ch



Commission Electrotechnique Internationale
International Electrotechnical Commission
Международная Электротехническая Комиссия

CODE PRIX
PRICE CODE

X

Pour prix, voir catalogue en vigueur
For price, see current catalogue

CONTENTS

FOREWORD.....	7
1 Scope.....	11
2 Normative references	11
3 Terms and definitions	11
4 General requirements.....	13
5 General conditions for the tests	13
6 Void.....	13
7 Classification.....	13
8 Marking and instructions.....	13
9 Protection against access to live parts.....	21
10 Starting	21
11 Input and current	21
12 Heating	21
13 Leakage current	21
14 Moisture resistance	21
15 Electric strength	21
16 Overload protection of transformers and associated circuits	21
17 Endurance.....	21
18 Abnormal operation	23
19 Mechanical hazards.....	23
20 Mechanical strength	33
21 Construction.....	33
22 Internal wiring.....	33
23 Components	33
24 Supply connection and external flexible cords	33
25 Terminals for external conductors.....	33
26 Provision for earthing	33
27 Screws and connections.....	35
28 Creepage distances, clearances and distances through insulation.....	35
29 Resistance to heat, fire and tracking.....	35
30 Resistance to rusting.....	35
31 Radiation, toxicity and similar hazards.....	35
Annexes	53
Annex K (normative) Battery tools and battery packs	53
Annex L (normative) Battery tools and battery packs provided with mains connection or non-isolated sources.....	53
Annex M (normative) Safety of working stands for operation with hand-held motor- operated electric tools)	55

Annex AA (normative) Additional requirements for saws with a riving knife	83
Annex BB (normative) Additional requirements for lower guards for saws without a riving knife	89
Bibliography	91
Figure 101 – Circular saw with outer pendulum guard	37
Figure 102 – Circular saw with inner pendulum guard	37
Figure 103 – Circular saw with tow guard	37
Figure 104 – Plunge type saw	37
Figure 105 – Test probe 'a'	39
Figure 106 – Aperture for blade and/or riving knife in the lower guard and aperture of the upper guard	39
Figure 107 – Distance from the gripping surface to the blade's cutting zone	41
Figure 108a – Height of viewing aperture	43
Figure 108b – Dimension U	43
Figure 108 – Height restriction of the viewing aperture (see 19.101.2.1)	43
Figure 109 – Distance from the edge of the lateral side of the upper guard to the guide plate	45
Figure 110 – Test probe 'b'	45
Figure 111 – Accessibility to the front cutting edge zone	47
Figure 112 – Blade exposure angle of the lower guard	49
Figure 113 – Principal dimensions of the guide plate	49
Figure 114 – Flange characteristics	51
Figure M.301 – Saw table fitted with hand-held circular saw	73
Figure M.302 – Testing the stability of the guard support	75
Figure M.303 – Saw table dimensions	77
Figure M.304 – Position of the outfeed end of the rip fence	77
Figure M.305 – Rip fence in low position	79
Figure M.306 – Examples of shapes of slot for locating cross-cut fence on saw tables	79
Figure M.307 – Examples of push stick and push blocks	81
Figure AA.101 – Riving knife stability test	87
Figure AA.102 – Riving knife adjustment	87