



Standard Practice for Installation of Precast Concrete Sewer, Storm Drain, and Culvert Pipe Using Standard Installations¹

This standard is issued under the fixed designation C 1479; the number immediately following the designation indicates the year of original adoption or, in the case of revision, the year of last revision. A number in parentheses indicates the year of last reapproval. A superscript epsilon (ϵ) indicates an editorial change since the last revision or reapproval.

^{ε1} NOTE—Corrected title, scope, 8.3, 15.2, and figure captions editorially in January 2001.

1. Scope

1.1 This practice covers the installation of precast concrete pipe intended to be used for the conveyance of sewage, industrial wastes, and storm water and for the construction of culverts.

1.2 *This standard does not purport to address all of the safety concerns, if any, associated with its use. It is the responsibility of the user of this standard to establish appropriate safety and health practices and determine the applicability of regulatory limitations prior to use.*

2. Referenced Documents

2.1 ASTM Standards:

C 822 Terminology Relating to Concrete Pipe and Related Products²

C 1417 Specification for Manufacture of Reinforced Concrete Sewer, Storm Drain, and Culvert Pipe for Direct Design²

D 698 Test Methods for Laboratory Compaction Characteristics of Soil Using Standard Effort (12,400 ft-lbf/ft³ (600 kN-m/m³))³

D 1557 Test Methods for Laboratory Compaction Characteristics of Soil Using Modified Effort (56,000 ft-lbf/ft³ (2,700 kN-m/m³))³

D 2487 Practice for Classification of Soils for Engineering Purposes (Unified Soil Classification System)³

D 2488 Practice for Description and Identification of Soils (Visual-Manual Procedure)³

IEEE/ASTM SI 10 Standard for Use of the International System of Units (SI): The Modern Metric System⁴

2.2 AASHTO Standards:⁵

Standard Specifications for Highway Bridges

T 99 The Moisture-Density Relations of Soils Using a 5.5 lb

(2.5 kg) Rammer and a 12-in. (305 mm) Drop
T 180 The Moisture-Density Relations of Soils Using a 10 lb (4.54 kg) Rammer and an 18-in. (457 mm) Drop

2.3 ASCE Standards:⁶

ASCE 15 Standard Practice for the Direct Design of Buried Precast Reinforced Concrete Pipe Using Standard Installations (SIDD)

3. Terminology

3.1 For definitions of terms relating to concrete pipe, see Terminology C 822.

3.2 For terminology related to soil classifications, see Practice D 2487 and Practice D 2488.

3.3 For terminology and definitions of terms relating to structural design, see ASCE 15.

3.4 Fig. 1 illustrates the definitions and limits of the terms: foundation, subgrade, bedding, outer bedding, middle bedding, haunch, lower side, backfill or overfill, invert, crown, springline, top of pipe, and bottom of pipe as used in this practice.

4. Significance and Use

4.1 This practice is useful as a reference by an owner and the owner's engineer in preparing project specifications.

5. Notations

D_i = inside diameter of pipe, in.

D_o = outside diameter of pipe, in.

H = design height of earth above top of pipe, ft.

w = unit weight of soil, lb/ft³.

6. Standard Installations

6.1 The precast concrete pipe/soil system shall be constructed to conform to the requirements of Figs. 2 and 3 and Tables 1 and 2 as designated on the plans.

7. Excavation

7.1 When ledge rock, compacted rocky, or other unyielding foundation material is encountered under the middle third of

⁶ Available from American Society of Civil Engineers (ASCE), 1801 Alexander Bell Drive, Reston, VA 20191-4400.

¹ This practice is under the jurisdiction of ASTM Committee C13 on Concrete Pipe and is the direct responsibility of Subcommittee C13.05 on Least Cost Analysis.

Current edition approved June 10, 2000. Published September 2000.

² Annual Book of ASTM Standards, Vol 04.05.

³ Annual Book of ASTM Standards, Vol 04.08.

⁴ Annual Book of ASTM Standards, Vol 14.02.

⁵ Available from American Association of State Highway and Transportation Officials (AASHTO), 444 North Capitol Street, NW, Suite 249, Washington, DC 20001.

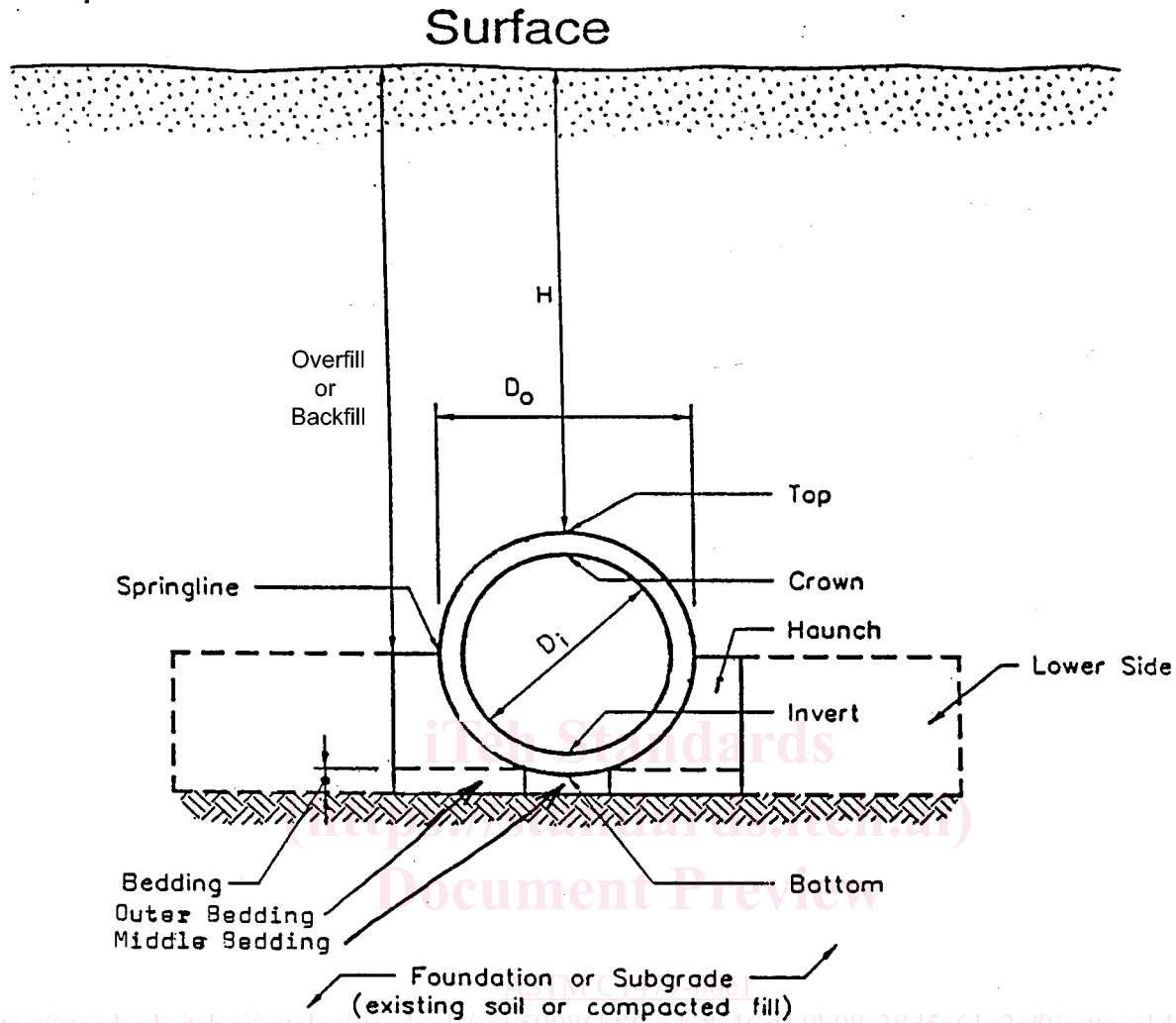

FIG. 1 Pipe/Installation Terminology

the pipe outside diameter, it shall be removed at least to the requirements shown in Figs. 1 and 2 and Tables 1 and 2. Overexcavated areas shall be backfilled with approved materials and compacted to at least the standard proctor density specified for the bedding.

7.2 Where surface water or groundwater conditions exist, the site and trench shall be dewatered.

8. Foundation

8.1 The foundation shall be moderately firm to hard in situ soil, stabilized soil, or compacted fill material.

8.2 When unsuitable or unstable material is encountered, the foundation shall be stabilized.

8.3 Methods to prevent migration of soil fines shall be provided when groundwater or existing soil conditions are conducive to particle migration. Gravelly soils, with little or no fines, could migrate under certain conditions, causing lack of support.

8.4 Pipe installed over an unyielding foundation shall be cushioned so as to prevent blasting shock when future blasting is anticipated in the area.

9. Bedding

9.1 The bedding shall be constructed uniformly over the full length of the pipe barrel, as required for the designated standard installation, to distribute the loadbearing reaction uniformly on the pipe barrel over its full length, and to maintain the required pipe grade. See Fig. 4. If placed in layers, the thickness of the layers shall be as required to achieve the specified compaction and as required by the project specifications.

9.2 The bedding layers for standard installation Types 1, 2, and 3 shall be placed to be as uniform as possible, but shall be loosely placed uncompacted material under the middle third of the pipe prior to placement of the pipe.

9.3 Except as provided in 11.4, the maximum aggregate size for beddings shall not be greater than 1 in. except if the bedding has a thickness of 6 in. or greater, then the maximum aggregate size shall not be greater than 1½ in.

9.4 When in situ soils conforming to project specifications are used in constructing the bedding for Type 3 and 4 Installations, the maximum aggregate size shall not be greater

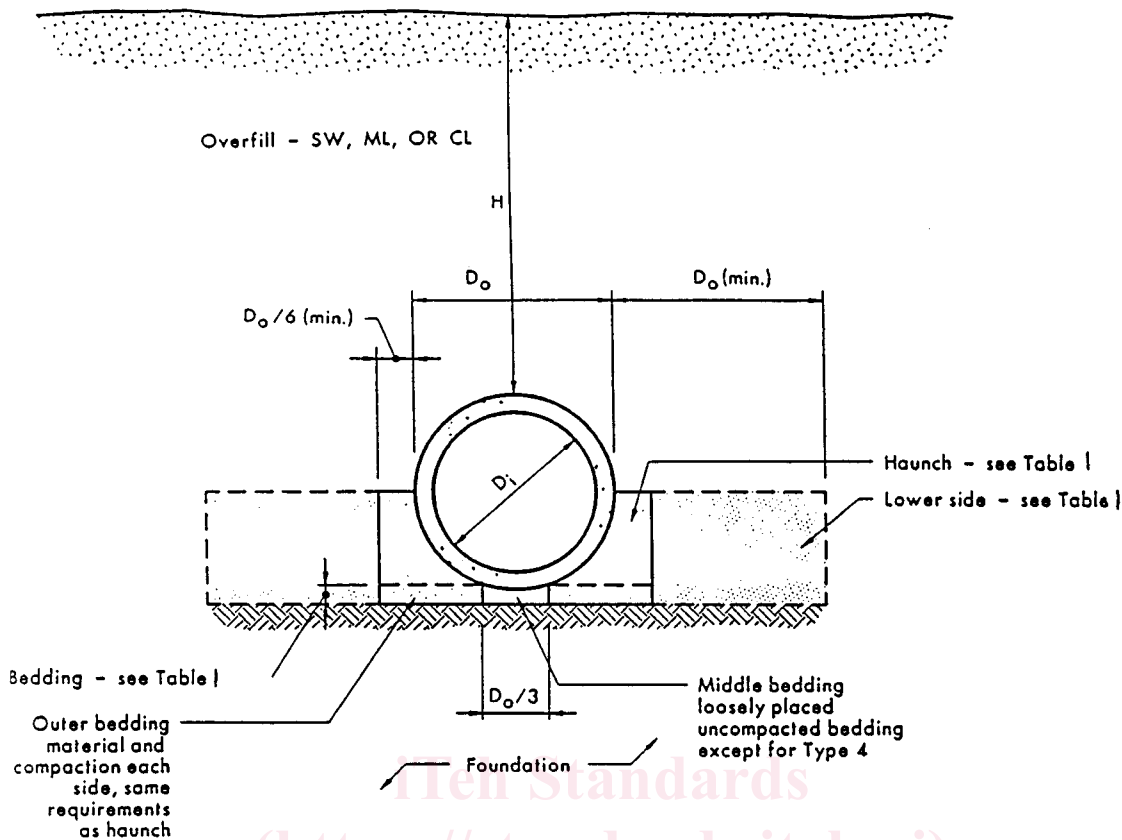

FIG. 2 Standard Embankment Installations

than 3 in., or half the bedding thickness, whichever is less.

9.5 Bell holes shall be excavated in the bedding or foundation, or both, when installing pipe with expanded bells so that the pipe is supported by the barrel and not by the bells. See Fig. 4.

9.6 Any outer bedding under the lower side areas shall be compacted to at least the same requirements as for the lower side areas.

10. Pipe Placement and Joining

10.1 Pipe shall be installed to the line and grade shown on the project plans and specifications. The joint shall be as specified in the project specifications and shall be installed in accordance with the pipe manufacturer's recommendations.

NOTE 1—Where practical, work should be started at the lowest end of the pipeline and the pipe laid with the bell end upgrade.

10.2 If required, the top of the pipe section being laid shall be positioned to the correct rotational orientation and then joined.

10.3 The bedding grade under the middle third of the pipe outside diameter shall be prepared before laying the pipe section. Making adjustments in grade by exerting force on the barrel of the pipe with excavating equipment, by lifting and dropping the pipe, or by lifting the pipe and packing bedding material under it shall be prohibited. If the installed pipe section is not on grade, the pipe section shall be completely unjoined, the grade corrected, and the pipe then rejoined.

11. Haunch

11.1 The haunch shall be constructed using the specified soil

type and the minimum compaction level required for the designated standard installation. It shall be placed and compacted uniformly for the full length of the pipe barrel so as to distribute the load-bearing reaction uniformly to the bedding over the full length of the pipe barrel. If placed in layers, the thickness of the layers shall be as required to achieve the specified compaction and as required by the project specifications.

11.2 Except as provided in 11.3, the maximum aggregate size for the haunch shall not be greater than 1 in. unless the bedding has a thickness of 6 in. or greater, then the maximum aggregate size shall not be greater than 1½ in.

11.3 When in situ soils conforming to project specifications are used in constructing the pipe haunches for Type 3 and 4 installations, the maximum aggregate size shall not be greater than 3 in.

11.4 Placed soil shall be deposited and compacted to the specified density uniformly on each side of the pipe to prevent lateral displacement of the pipe.

12. Lower Side

12.1 The lower side, if not in situ, shall be constructed using the specified soil type and the minimum compaction level required for the designated standard installation. If placed in layers, the thickness of the layers shall be as required to achieve the specified compaction and as required by the project specifications.

12.2 The soil, if not in situ, shall be material conforming to the project specifications, and contain no debris, organic matter, frozen material, or large stones with a diameter greater

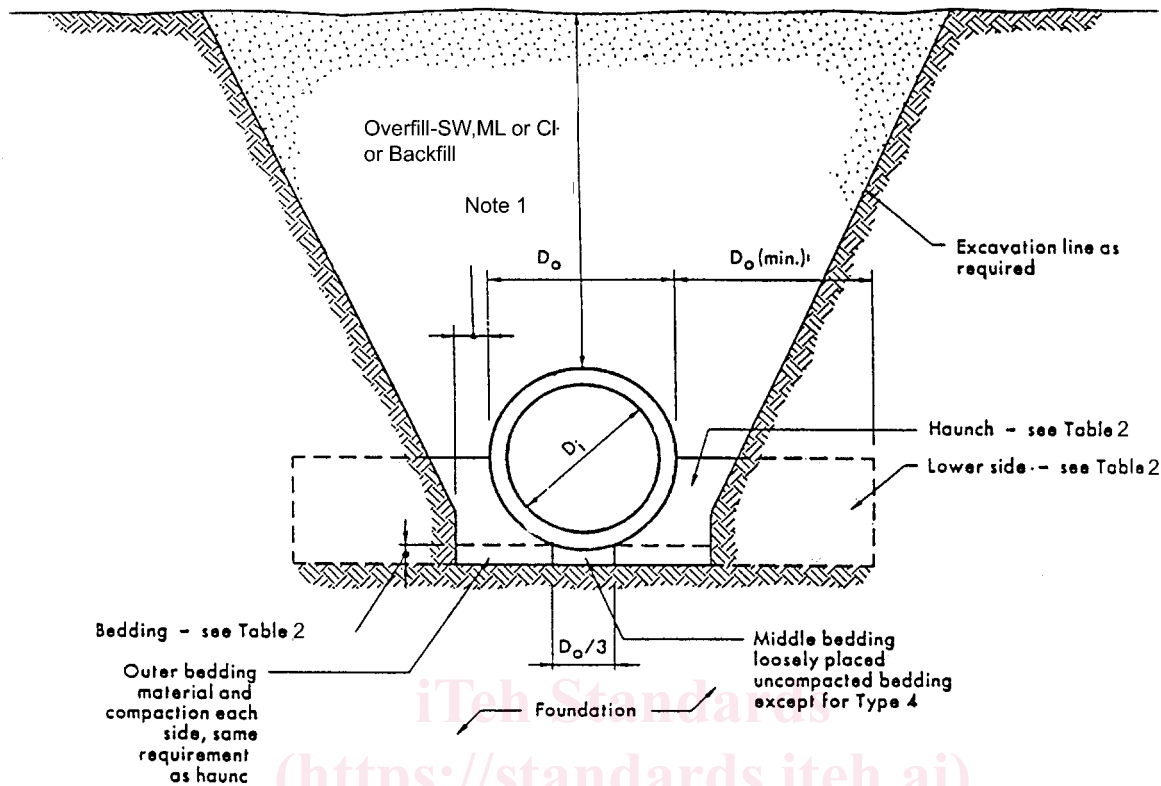

NOTE 1—Clearance between pipe and trench wall shall be adequate to enable specified compaction but not less than $D_0/6$.

FIG. 3 Standard Trench Installations

than one half the thickness of the compacted layers being placed.

12.3 Placed soil shall be deposited and compacted to the specified density uniformly on each side of the pipe to prevent lateral displacement of the pipe.

13. Overfill

13.1 Overfill shall be constructed as specified in the project specifications. If placed in layers, the thickness of the layers shall be as required to achieve the specified compaction and as required by the project specifications.

13.2 The soil shall be material conforming to the project specifications, and contain no debris, organic matter, frozen material, or large stones with a diameter greater than one half the thickness of the compacted layers being placed.

13.3 Placed soil shall be deposited and compacted to the specified density uniformly on each side of the pipe to prevent lateral displacement of the pipe. The overfill placed within one outside diameter of the pipe that is above the springline and below the top of the pipe shall be compacted to at least the same density as the majority of the overfill above the pipe.

13.4 When impact or vibratory equipment is used for compaction, care shall be taken to avoid damaging the pipe.

14. Sheathing Removal and Trench Shield Advancement

14.1 Unless sheathing is to be left in place, it shall be pulled out in vertical increments to permit placement and compaction

of fill material for the full width of the trench.

14.2 When trench shields or boxes are moved, the previously placed pipe shall not be disturbed. It may be necessary to restrain the installed pipe by use of deadman anchors or other means. Voids that are created by movement of a shield or box shall be filled and compacted.

15. Precast Concrete Appurtenances

15.1 Manholes shall be installed in a manner that will minimize differential settlement between the pipe and manhole.

15.2 Precast concrete fittings, such as tees and wyes, shall be bedded, installed, and overfilled with the same material and in the same manner as the remainder of the pipeline to reduce the possibility of differential settlement between pipe and fittings.

16. Minimum Cover for Construction Loads

16.1 If the passage of construction equipment over an installed pipeline is necessary during project construction, compacted overfill in the form of a ramp shall be constructed to a minimum elevation of 3 ft over the top of the pipe or to a height such that the equipment loads on the pipe do not exceed the pipe design strength. To prevent possible lateral displacement of the pipe when the existing ground is higher or lower than the top of this ramp, the overfill shall extend a minimum of one pipe diameter width or 3 ft, whichever is greater, beyond