

# INTERNATIONAL STANDARD

ISO  
8906

First edition  
1988-07-15



---

INTERNATIONAL ORGANIZATION FOR STANDARDIZATION  
ORGANISATION INTERNATIONALE DE NORMALISATION  
МЕЖДУНАРОДНАЯ ОРГАНИЗАЦИЯ ПО СТАНДАРТИЗАЦИИ

---

## Sawn timber — Test methods — Determination of resistance to local transverse compression

*Bois sciés — Méthodes d'essai — Détermination de la résistance à la compression localisée  
transversale*

**(standards.iteh.ai)**

ISO 8906:1988

<https://standards.iteh.ai/catalog/standards/sist/f7837a86-bbbb-4f99-9bb3-2844fc55dae4/iso-8906-1988>

Reference number  
ISO 8906:1988 (E)

## Foreword

ISO (the International Organization for Standardization) is a worldwide federation of national standards bodies (ISO member bodies). The work of preparing International Standards is normally carried out through ISO technical committees. Each member body interested in a subject for which a technical committee has been established has the right to be represented on that committee. International organizations, governmental and non-governmental, in liaison with ISO, also take part in the work. ISO collaborates closely with the International Electrotechnical Commission (IEC) on all matters of electrotechnical standardization.

Draft International Standards adopted by the technical committees are circulated to the member bodies for approval before their acceptance as International Standards by the ISO Council. They are approved in accordance with ISO procedures requiring at least 75 % approval by the member bodies voting.

International Standard ISO 8906 was prepared by Technical Committee ISO/TC 55, *Sawn timber and sawlogs*.

[ISO 8906:1988](#)

Users should note that all International Standards undergo revision from time to time and that any reference made herein to any other International Standard implies its latest edition, unless otherwise stated.

# Sawn timber — Test methods — Determination of resistance to local transverse compression

## 1 Scope and field of application

This International Standard specifies a method of determining the resistance of sawn timber of coniferous and broadleaved species to local transverse compression.

It does not cover testing of small defect-free test pieces of wood.

## 2 Reference

ISO 3130, *Wood — Determination of moisture content for physical and mechanical tests.*

## 3 Principle

Determination from the "load/deflection" curve of the load proportional limit and the load at a given deformation, and calculation of the stresses at these loads.

## 4 Apparatus

**4.1 Test machine,** with a device registering load increments of less than 100 N/mm and deformation of the test piece of less than 0,02 mm/mm. In the absence of such a machine with a registering device, a test machine measuring the load to an accuracy of  $\pm 1\%$  and capable of maintaining the test rate specified in 6.2 shall be used.

**4.2 Device,** capable of ensuring uniform loading of the test piece by means of a punch of width 50 mm and length at least 10 mm greater than the thickness of the sawn timber to be tested. The edges of the punch shall be rounded to a radius of 2 mm.

For machines without a registering device, the unit shall be equipped with an instrument capable of measuring the deformation of the test piece to an accuracy of 0,01 mm.

**4.3 Measuring instrument,** to determine the width of the test piece to an accuracy of 0,1 mm.

**4.4 Equipment for the determination of moisture content,** in accordance with ISO 3130.

## 5 Preparation of test pieces

**5.1** The test piece, in the form of a right-sided prism of length 150 mm and height 50 mm, shall be cut from areas nearest to the edge of the sawn timber to be tested over the whole thickness,  $t$  (see figure 1).

The measured surfaces of the test piece (formed by the edge of the board and the edge opposite) shall be parallel.

The test piece may be cut from the portions of sawn timber left after sampling for other tests.

iTeh STANDARD PREVIEW  
(standards.itech.ai)

ISO 8906:1988

<https://standards.itech.ai/catalog/standards/sist/17837a86-bbbb-4f99-9bb3-2844fc55dae4/iso-8906-1988>

Dimensions in millimetres

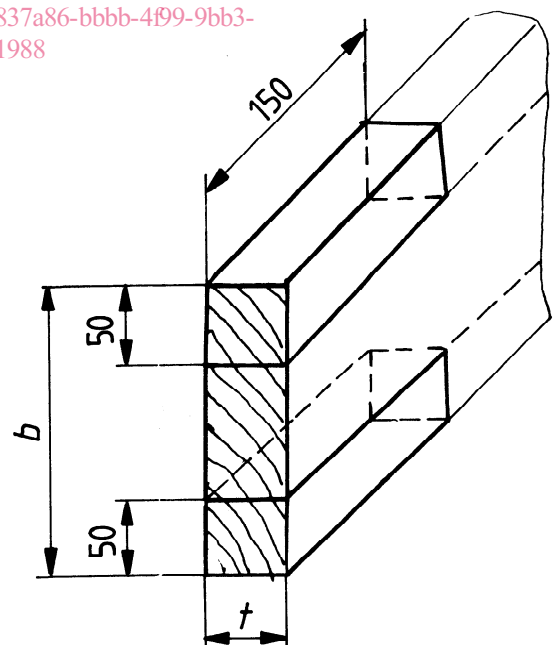

Figure 1 — Test pieces

**5.2** To determine the minimum resistance value to local transverse compression, select the test pieces from the weakest portions of the sawn timber to be tested; this can be determined either visually or by the results of mechanized grading. Defects increasing the resistance of wood to compression are not permitted in the test piece.

5.3 The moisture content shall be in accordance with the technical requirements for sawn timber.

## 6 Procedure

6.1 Measure the width,  $t$ , of the working surface, in millimetres, in the middle of the test piece length.

6.2 Place the test piece in the device (4.2) so that the working surface formed by the edge of the board is upwards. Place the punch across the test piece at equal distances from the ends and at right angles to the longitudinal axis of the test piece.

Place the device with a test piece in the test machine (4.1). Load the test piece continuously with a constant rate of stress or a constant rate of movement of the loading head, simultaneously noting the load and deformation with a registering device. The rate of increase shall be such that the duration of the test shall be not less than 2 min.

6.3 In the absence of a machine with a registering device, place the test piece in the testing device with a measuring instrument (4.3) to measure the deformation and load in ac-

cordance with 6.2, periodically measuring the load and the resulting deformation of the test piece. Take at least 10 readings at equal load increase intervals.

6.4 Continue testing until a deformation of 2,5 mm is reached; this can be determined from the machine diagram of compression or from the readings of the instrument measuring the deformation. The load  $F_{max}$ , corresponding to the deformation, shall be registered.

6.5 After completion of the test, determine the moisture content of the test piece in accordance with ISO 3130.

## 7 Calculation and expression of results

7.1 In the absence of a machine with a registering device, draw a diagram from the readings of load and deflection obtained according to 6.3, with scales of not greater than 100 N/mm on the ordinate and not greater than 0,02 mm/mm on the abscissa.

The load  $F$ , corresponding to the conventional ultimate stress, shall be determined on the "load/deflection" curve as the ordinate of the point where the tangent of the angle, formed by the load axis with the tangent to the curve, exceeds by 50 % its value in the linear portion of the diagram (see figure 2).

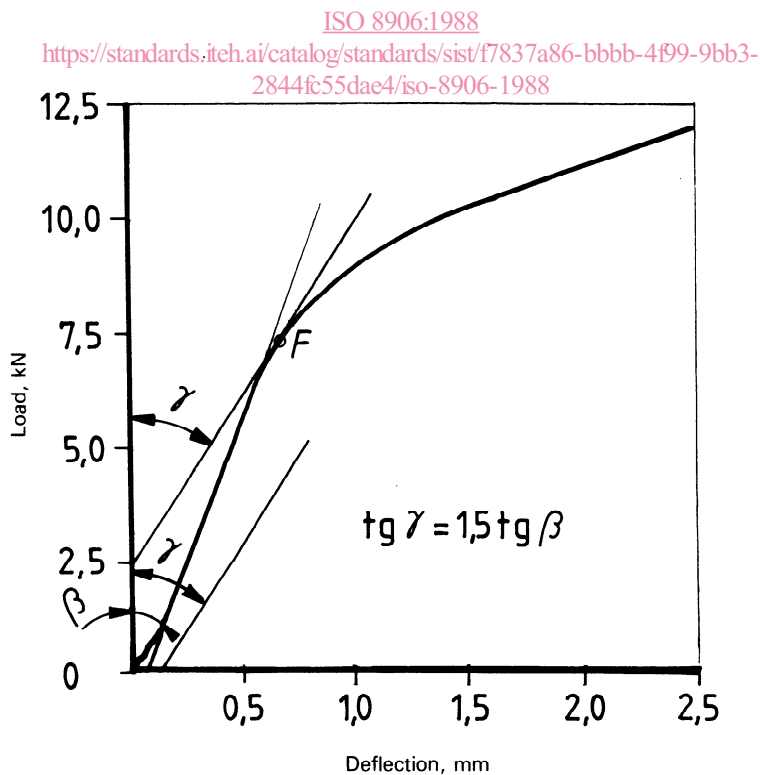

Figure 2 — "Load/deflection" curve

**7.2** Calculate the conventional ultimate contact resistance,  $\sigma_y^W$ , in local transverse compression, and the stress which occurs in the test piece at the deflection of 2,5 mm,  $\sigma_{2,5}^W$ , and a moisture content,  $W$ , at the time of testing, in megapascals, using the formulae

$$\sigma_y^W = \frac{F}{48t}$$

$$\sigma_{2,5}^W = \frac{F_{\max}}{50t}$$

where

$F$  is the load, in newtons, corresponding to the conventional ultimate stress in local transverse compression;

$F_{\max}$  is the load, in newtons, causing 2,5 mm deflection of the test piece;

$t$  is the width of the working surface, in millimetres;

the numerals 48 and 50 are expressed in millimetres.

Calculate  $\sigma_y^W$  and  $\sigma_{2,5}^W$  to three significant figures.

The test results shall be the arithmetical averages of  $\sigma_y^W$  and  $\sigma_{2,5}^W$  of the test pieces tested.

## 8 Test report

The test report shall contain the following particulars :

- a) a reference to this International Standard;
- b) details of the wood species;
- c) the dimensions and grade of sawn timber;
- d) information on sampling of the test pieces;
- e) the moisture content of the test pieces;
- f) the test results calculated as specified in clause 7.

NOTE — If necessary, the test report may include also the result of a measurement of the angle formed by the tangent to the growth rings with the shearing plane.

## iTeh STANDARD PREVIEW (standards.iteh.ai)

[ISO 8906:1988](#)

<https://standards.iteh.ai/catalog/standards/sist/f7837a86-bbbb-4f99-9bb3-2844fc55dae4/iso-8906-1988>

**iTeh STANDARD PREVIEW**  
**(standards.iteh.ai)**

This page intentionally left blank

[ISO 8906:1988](#)

<https://standards.iteh.ai/catalog/standards/sist/f7837a86-bbbb-4f99-9bb3-2844fc55dae4/iso-8906-1988>

**iTeh STANDARD PREVIEW**  
**(standards.iteh.ai)**

This page intentionally left blank

[ISO 8906:1988](#)

<https://standards.iteh.ai/catalog/standards/sist/f7837a86-bbbb-4f99-9bb3-2844fc55dae4/iso-8906-1988>

**iTeh STANDARD PREVIEW**  
**(standards.iteh.ai)**

ISO 8906:1988

<https://standards.iteh.ai/catalog/standards/sist/f7837a86-bbbb-4f99-9bb3-2844fc55dae4/iso-8906-1988>

---

**UDC 674.03 : 620.173**

**Descriptors :** wood, sawn timber, structural timber, tests, compression tests.

Price based on 3 pages

---