



SLOVENSKI STANDARD

SIST EN 3282:2001

01-januar-2001

Aerospace series - Bearings, airframe rolling - Rigid single row ball bearings in steel, cadmium plated - Diameter series 8 and 9 - Dimensions and loads

Aerospace series - Bearings, airframe rolling - Rigid single row ball bearings in steel, cadmium plated - Diameter series 8 and 9 - Dimensions and loads

Luft- und Raumfahrt - Flugwerkklager - Einreihige Rillenkugellager aus Stahl, verkadmet - Durchmesserreihen 8 und 9 - Maße und Belastungen

Série aérospatiale - Roulements pour structures d'aéronefs - Roulements en acier, cadmiés, rigides, à une rangée de billes - Série de diamètres 8 et 9 - Dimensions et charges

<https://standards.iteh.ai/catalog/standards/sist/444e3eaa-fe1e-48cb-a611-76eff64d4e4b/sist-en-3282-2001>

Ta slovenski standard je istoveten z: EN 3282:1994

ICS:

49.035	Sestavni deli za letalsko in vesoljsko gradnjo	Components for aerospace construction
--------	--	---------------------------------------

SIST EN 3282:2001

en

iTeh STANDARD PREVIEW
(standards.iteh.ai)

SIST EN 3282:2001

<https://standards.iteh.ai/catalog/standards/sist/444e3eaa-fe1e-48cb-a611-76eff64d4e4b/sist-en-3282-2001>

EUROPEAN STANDARD

EN 3282

NORME EUROPÉENNE

EUROPÄISCHE NORM

May 1994

UDC 629.7.02:621.822.74.004.1:669.14:669.738

Descriptors: Aircraft industry, airframe bearings, ball bearings, steel, cadmium, dimensions, static loads

English version

**Aerospace series - Bearings, airframe rolling -
Rigid single row ball bearings in steel, cadmium
plated - Diameter series 8 and 9 - Dimensions and
loads**

Série aérospatiale - Roulements pour structures
d'aéronefs - Roulements en acier, cadmiés,
rigides, à une rangée de billes - Série de
diamètres 8 et 9 - Dimensions et charges

Luft- und Raumfahrt - Flugwerklager -
Einreihige Rillenkugellager aus Stahl,
verkadmet - Durchmesserreihen 8 und 9 - Maße
und Belastungen

STANDARD PREVIEW
standards.iteh.eu

SIST EN 3282:2001

<https://standards.iteh.ai/catalog/standards/sist/444e3eaa-fe1e-48cb-a611-76eff64d4e4b/sist-en-3282-2001>

This European Standard was approved by CEN on 1994-05-19. CEN members are bound to comply with the CEN/CENELEC Internal Regulations which stipulate the conditions for giving this European Standard the status of a national standard without any alteration.

Up-to-date lists and bibliographical references concerning such national standards may be obtained on application to the Central Secretariat or to any CEN member.

The European Standards exist in three official versions (English, French, German). A version in any other language made by translation under the responsibility of a CEN member into its own language and notified to the Central Secretariat has the same status as the official versions.

CEN members are the national standards bodies of Austria, Belgium, Denmark, Finland, France, Germany, Greece, Iceland, Ireland, Italy, Luxembourg, Netherlands, Norway, Portugal, Spain, Sweden, Switzerland and United Kingdom.

CEN

European Committee for Standardization
Comité Européen de Normalisation
Europäisches Komitee für Normung

Central Secretariat: rue de Stassart, 36 B-1050 Brussels

Foreword

This European Standard has been prepared by the European Association of Aerospace Manufacturers (AECMA).

After inquiries and votes carried out in accordance with the rules of this Association, this Standard has successively received the approval of the National Associations and the Official Services of the member countries of AECMA, prior to its presentation to CEN.

This standard was submitted for Formal Vote, and the result was positive.

This European Standard shall be given the status of a national standard, either by publication of an identical text or by endorsement, at the latest by November 1994, and conflicting national standards shall be withdrawn at the latest by November 1994.

According to the CEN/CENELEC Internal Regulations, the following countries are bound to implement this European Standard: Austria, Belgium, Denmark, Finland, France, Germany, Greece, Iceland, Ireland, Italy, Luxembourg, Netherlands, Norway, Portugal, Spain, Sweden, Switzerland, United Kingdom.

(standards.iteh.ai)

SIST EN 3282:2001

[https://standards.iteh.ai/catalog/standards/sist/444e3eaa-fe1e-48cb-a611-](https://standards.iteh.ai/catalog/standards/sist/444e3eaa-fe1e-48cb-a611-76eff54d4e4b/sist-en-3282-2001)

76eff54d4e4b/sist-en-3282-2001
ALIN IVOLIS PARTIGUEN
TFO98 IN TECHNIS ONTEL08 AS ONTONTENIN
opoleavom ni ofjessimbnoic on 871 hant
ANAL08UUL
.....T010
ONTIDAL08EAO I08TUM 08 T08V879

1 Scope

This standard specifies the characteristics of rigid single row ball bearings in steel ¹⁾, cadmium plated, of diameter series 8 and 9 ²⁾ designed to withstand only slow rotations and oscillations under load.

They are intended for use between fixed and moving parts of the aircraft structure and their control mechanisms.

The airframe rolling bearings defined in this standard are used from - 54 °C to + 150 °C.

However, being lubricated with the following greases :

- very high pressure grease, ester type (code A), operational range - 73 °C to + 121 °C or
- very high pressure grease, synthetic hydrocarbons, general purpose (code B), operational range - 54 °C to + 177 °C (see EN 3280),

their field of application when lubricated with code A grease is limited to + 121 °C.

2 Normative references

This European Standard incorporates by dated or undated reference provisions from other publications. These normative references are cited at the appropriate places in the text and the publications are listed hereafter. For dated references, subsequent amendments to or revisions of any of these publications apply to this European Standard only when incorporated in it by amendment or revision. For undated references the latest edition of the publication referred to applies.

ISO 15	Rolling bearings - Radial bearings - Boundary dimensions - General plan
ISO 1132	Rolling bearings - Tolerances - Definitions
EN 2031	Steel FE-PL31 - Hardened and tempered - Bars - Aerospace series ³⁾
EN 2133	Cadmium plating of steels with maximum specified tensile strength equal to or less than 1450 MPa and copper and copper alloys - Aerospace series ³⁾
EN 2221	Steel FE-PL31 - Hardened and tempered - Hollow bars 3,5 mm ≤ a ≤ 55 mm - Aerospace series ³⁾
EN 2222	Steel FE-PL31 - Hardened and tempered - Hand and die forgings - Aerospace series ³⁾
EN 3280	Aerospace series - Bearings, airframe rolling, rigid or self-aligning - Technical specification
EN 3283	Aerospace series - Bearings, airframe rolling - Rigid single row ball bearings in corrosion resisting steel - Diameter series 8 and 9 - Dimensions and loads

3 Definition

For the purposes of this standard, the following definition applies :

Bearing : full complement of balls (without cage), with filling slot.

4 Symbols

The definitions of tolerances and clearances are given in ISO 1132.

Δ_{dmp}	= single plane mean bore diameter deviation
Δ_{Dmp}	= single plane mean outside diameter deviation
G_a	= axial internal clearance
G_r	= radial internal clearance
S_{ia}	= assembled bearing inner ring face runout with raceway
S_{ea}	= assembled bearing outer ring face runout with raceway
K_{ia}	= radial runout of assembled bearing inner ring
K_{ea}	= radial runout of assembled bearing outer ring
$F_a \text{ max.}$	= permissible static axial load
C_s	= permissible static radial load.

1) For new design, use preferably bearings in corrosion resisting steel, see EN 3283

2) See ISO 15

3) Published as AECMA Standard at the date of publication of this standard

5 Required characteristics

5.1 Dimensions - Tolerances - Clearances - Loads - Mass

Configuration : see figure 1 ; the bearings are fitted with either seals or shields.

Values : see table 1 ; the dimensions and tolerances apply after protection.

5.2 Surface roughness

Raceways and rolling elements : $R_a = 0,2 \mu\text{m}$

Bore, side faces and cylindrical outer surface : $R_a = 0,8 \mu\text{m}$

The values apply prior to cadmium plating.

5.3 Materials

Inner ring : EN 2031 or EN 2221 or EN 2222, 59 HRC to 64 HRC

Outer ring : EN 2031 or EN 2221 or EN 2222, 59 HRC to 64 HRC

Balls : EN 2031, 59 HRC to 64 HRC

Shields : Corrosion resisting material

Seals : Polytetrafluoroethylene (PTFE) or polytetrafluoroethylene (PTFE) reinforced with fibreglass.

5.4 Surface treatment

EN 2133 thickness, $5 \mu\text{m}$ to $12 \mu\text{m}$, on the inner and outer rings, the bore and raceways are not cadmium plated.

As soon as possible after plating, and within 16 h de-embrittlement heat treatment shall be carried out at a temperature and for a time (compatible with the performance requirements of the bearing) which shall be subject to written approval of the qualifying authorities.

iTeh STANDARD PREVIEW
(standards.iteh.ai)

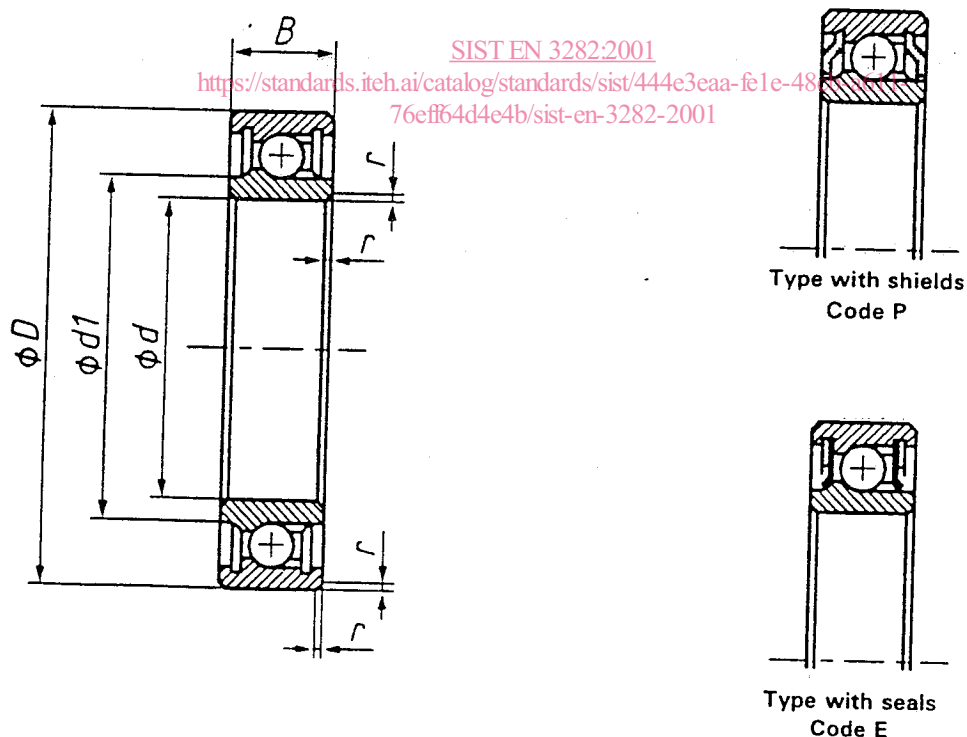

NOTE 1 : The installation of seals and shields is at the manufacturer's option.

NOTE 2 : The shields shall not extend beyond « B ».

Figure 1

Table 1

Dimensions in millimetres

d		B 0 - 0,12	D	d1 min.	Tolerances μm		r	Mass kg/1000 parts \approx
Code	Nominal				Δ_{dmp}	Δ_{Dmp}		
10	10	6	22	13	0 - 8	0 - 9	0,3 to 0,8	11
12	12		24	15				13
15	15		28	17,6				16
17	17	7	30	19,6	0 -10	0 -11	0,3 to 0,8	18
20	20		32	23				20
25	25		37	28,1				23
30	30		42	33,1				26
35	35		47	38,3				30
40	40		52	43,3				38
50	50	10	65	53	0 -12	0 -13	0,3 to 0,8	55
60	60		78	63,5				100

iTeh STANDARD PREVIEW

(standards.iteh.ai)

d Code	Internal clearances μm		Runout tolerances max. μm				Starting torque ¹⁾ in mN.m		Permissible static loads ²⁾ kN	
	Axial max G_a	Radial G_r	Axial		Radial		Code	Code	Axial	Radial
			S_{ia}	S_{ea}	K_{ia}	K_{ea}	P	E	F_a max.	C_s
10	100	2 to 13	40	40	25	40	4,5	12	4,8	10,6
12		3 to 18					5	13	5,6	12,3
15							5,5	14	7,4	16,2
17							6	15	8	17,6
20							6,5	16	7,9	17,3
25		5 to 20					8,5	18	9,8	21,5
30							14	20	11,1	24,5
35							18	23	12,9	28,4
40	6 to 20	22	29	14,5	31,8					
50		120	6 to 23	32	47	19,6	43,1			
60	150	8 to 28	55	77	31,8	70				

1) Definition, see EN 3280.

2) Axial and radial loads may be applied simultaneously.
For ultimate static loads, see EN 3280.

6 Designation

EXAMPLE :

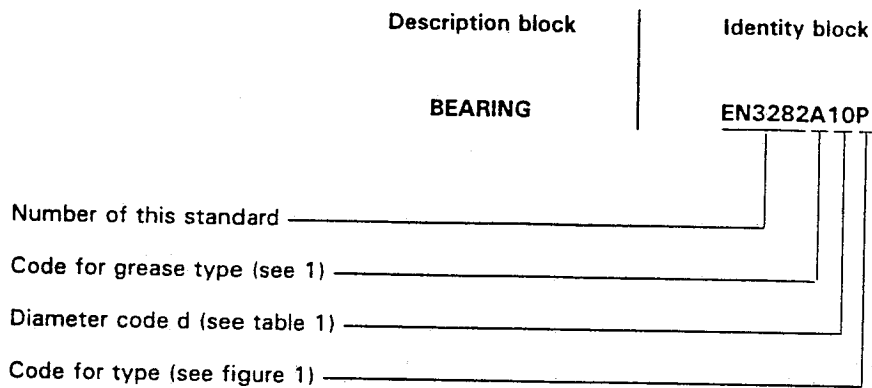

NOTE : If necessary, the code 19005 shall be placed between the description block and the identity block.

7 Marking

In addition to the manufacturer's own marking, each bearing shall be marked, on one side face only, using the identity block, see 6.

Marking position and method are at the manufacturer's option.

iTeh STANDARD PREVIEW
(standards.iteh.ai)

8 Technical specification

See EN 3280.

[SIST EN 3282:2001](https://standards.iteh.ai/catalog/standards/sist/444e3caa-fe1e-48cb-a611-76eff64d4e4b/sist-en-3282-2001)

<https://standards.iteh.ai/catalog/standards/sist/444e3caa-fe1e-48cb-a611-76eff64d4e4b/sist-en-3282-2001>