

INTERNATIONAL STANDARD

NORME INTERNATIONALE

Connectors for electronic equipment – Product requirements –
Part 3-118: Rectangular connectors – Detail specification for a 4 pole plus PE
power connector with push-pull coupling

Connecteurs pour équipements électroniques – Exigences de produit –
Partie 3-118: Connecteurs rectangulaires – Spécification particulière relative à
un connecteur de puissance à 4 pôles plus PE avec mécanisme de couplage
pousser-tirer



THIS PUBLICATION IS COPYRIGHT PROTECTED

Copyright © 2010 IEC, Geneva, Switzerland

All rights reserved. Unless otherwise specified, no part of this publication may be reproduced or utilized in any form or by any means, electronic or mechanical, including photocopying and microfilm, without permission in writing from either IEC or IEC's member National Committee in the country of the requester.

If you have any questions about IEC copyright or have an enquiry about obtaining additional rights to this publication, please contact the address below or your local IEC member National Committee for further information.

Droits de reproduction réservés. Sauf indication contraire, aucune partie de cette publication ne peut être reproduite ni utilisée sous quelque forme que ce soit et par aucun procédé, électronique ou mécanique, y compris la photocopie et les microfilms, sans l'accord écrit de la CEI ou du Comité national de la CEI du pays du demandeur.

Si vous avez des questions sur le copyright de la CEI ou si vous désirez obtenir des droits supplémentaires sur cette publication, utilisez les coordonnées ci-après ou contactez le Comité national de la CEI de votre pays de résidence.

IEC Central Office
3, rue de Varembe
CH-1211 Geneva 20
Switzerland
Email: inmail@iec.ch
Web: www.iec.ch

About the IEC

The International Electrotechnical Commission (IEC) is the leading global organization that prepares and publishes International Standards for all electrical, electronic and related technologies.

About IEC publications

The technical content of IEC publications is kept under constant review by the IEC. Please make sure that you have the latest edition, a corrigenda or an amendment might have been published.

- Catalogue of IEC publications: www.iec.ch/searchpub

The IEC on-line Catalogue enables you to search by a variety of criteria (reference number, text, technical committee,...). It also gives information on projects, withdrawn and replaced publications.

- IEC Just Published: www.iec.ch/online_news/justpub

Stay up to date on all new IEC publications. Just Published details twice a month all new publications released. Available on-line and also by email.

[IEC 61076-3-118:2010](mailto:IEC.61076-3-118:2010)

- Electropedia: www.electropedia.org

The world's leading online dictionary of electronic and electrical terms containing more than 20 000 terms and definitions in English and French, with equivalent terms in additional languages. Also known as the International Electrotechnical Vocabulary online.

- Customer Service Centre: www.iec.ch/webstore/custserv

If you wish to give us your feedback on this publication or need further assistance, please visit the Customer Service Centre FAQ or contact us:

Email: csc@iec.ch

Tel.: +41 22 919 02 11

Fax: +41 22 919 03 00

A propos de la CEI

La Commission Electrotechnique Internationale (CEI) est la première organisation mondiale qui élabore et publie des normes internationales pour tout ce qui a trait à l'électricité, à l'électronique et aux technologies apparentées.

A propos des publications CEI

Le contenu technique des publications de la CEI est constamment revu. Veuillez vous assurer que vous possédez l'édition la plus récente, un corrigendum ou amendement peut avoir été publié.

- Catalogue des publications de la CEI: www.iec.ch/searchpub/cur_fut-f.htm

Le Catalogue en-ligne de la CEI vous permet d'effectuer des recherches en utilisant différents critères (numéro de référence, texte, comité d'études,...). Il donne aussi des informations sur les projets et les publications retirées ou remplacées.

- Just Published CEI: www.iec.ch/online_news/justpub

Restez informé sur les nouvelles publications de la CEI. Just Published détaille deux fois par mois les nouvelles publications parues. Disponible en-ligne et aussi par email.

- Electropedia: www.electropedia.org

Le premier dictionnaire en ligne au monde de termes électroniques et électriques. Il contient plus de 20 000 termes et définitions en anglais et en français, ainsi que les termes équivalents dans les langues additionnelles. Egalement appelé Vocabulaire Electrotechnique International en ligne.

- Service Clients: www.iec.ch/webstore/custserv/custserv_entry-f.htm

Si vous désirez nous donner des commentaires sur cette publication ou si vous avez des questions, visitez le FAQ du Service clients ou contactez-nous:

Email: csc@iec.ch

Tél.: +41 22 919 02 11

Fax: +41 22 919 03 00



IEC 61076-3-118

Edition 1.0 2010-04

INTERNATIONAL STANDARD

NORME INTERNATIONALE

**Connectors for electronic equipment – Product requirements –
Part 3-118: Rectangular connectors – Detail specification for a 4 pole plus PE
power connector with push-pull coupling**

**Connecteurs pour équipements électroniques – Exigences de produit –
Partie 3-118: Connecteurs rectangulaires – Spécification particulière relative à
un connecteur de puissance à 4 pôles plus PE avec mécanisme de couplage
pousser-tirer**

INTERNATIONAL
ELECTROTECHNICAL
COMMISSION

COMMISSION
ELECTROTECHNIQUE
INTERNATIONALE

PRICE CODE
CODE PRIX

U

ICS 31.220.10

ISBN 978-2-88910-409-3

CONTENTS

FOREWORD.....	5
1 Scope.....	8
1.1 General considerations.....	8
1.2 Normative references.....	8
2 Technical information.....	9
2.1 Terms and definitions.....	9
2.2 Systems of levels.....	9
2.2.1 Performance levels.....	9
2.2.2 Compatibility levels, according to IEC 61076-1 Ed. 2.0.....	9
2.3 Classification into climatic categories.....	9
2.4 Clearance and creepage distances.....	9
2.5 Current-carrying capacity.....	10
2.6 Marking.....	10
3 Dimensional information.....	10
3.1 General.....	10
3.2 Isometric view and common features.....	11
3.2.1 Common features.....	11
3.2.2 Reference system.....	11
3.3 Engagement (mating) information.....	11
3.3.1 Engaging (mating) direction.....	11
3.3.2 Perpendicular to the engaging (mating) direction.....	11
3.3.3 Inclination.....	11
3.4 Fixed connectors.....	12
3.4.1 Dimensions.....	12
3.4.2 Terminations.....	13
3.5 Free connectors.....	14
3.5.1 Dimensions.....	14
3.5.2 Terminations.....	14
3.6 Accessories.....	14
3.7 Mounting information for connectors.....	14
3.7.1 Mounting on panels.....	14
3.8 Gauges.....	15
3.8.1 Sizing gauges and retention force gauges.....	15
3.8.2 Mechanical function, engaging/separating/insertion/withdrawal force gauges.....	16
3.8.3 Probes.....	16
3.8.4 Contact resistance gauge.....	16
3.8.5 Test panel (for voltage proof test).....	16
3.8.6 Test panel (for EMC/ crosstalk, etc.).....	16
4 Characteristics.....	16
4.1 General.....	16
4.2 Pin assignment and other definitions.....	16
4.3 Classification into climatic categories.....	16
4.4 Electrical characteristics.....	16
4.4.1 Creepage and clearance distances.....	16
4.4.2 Voltage proof.....	17
4.4.3 Current-carrying capacity.....	17

4.4.4	Contact resistance.....	17
4.4.5	Insulation resistance.....	17
4.4.6	Impedance.....	17
4.4.7	Transmission characteristics.....	17
4.5	Mechanical characteristics	17
4.5.1	Mechanical operation	17
4.5.2	Effectiveness of connector coupling devices.....	17
4.5.3	Insertion and withdrawal forces	17
4.5.4	Contact retention in insert.....	18
4.5.5	Polarizing and coding method.....	18
4.6	Other characteristics	18
4.6.1	Shock and vibration (method sine).....	18
4.6.2	Degree of protection provided by enclosures (IP-code).....	18
4.6.3	Screen and shielding properties	18
4.7	Environmental aspects	18
4.7.1	Marking of insulation material (plastics).....	18
4.7.2	Design/ use of material.....	18
5	Test schedule.....	18
5.1	General.....	18
5.1.1	Climatic category.....	19
5.1.2	Clearance and creepage distances.....	19
5.1.3	Arrangement for contact resistance measurement	19
5.1.4	Arrangement for dynamic stress tests.....	19
5.1.5	Arrangement for testing static load; axial.....	19
5.1.6	Wiring of specimens.....	19
5.2	Test schedules.....	19
5.2.1	Basic (minimum) test schedule	19
5.2.2	Full test schedule	19
5.3	Test procedures and measuring methods	26
5.4	Preconditioning	26
5.5	Wiring and mounting of specimens	27
5.5.1	Wiring.....	27
5.5.2	Mounting	27
	Bibliography.....	28
	Figure 1 – Fixed (male) and free (female) connector.....	11
	Figure 2 – Fixed male connector.....	12
	Figure 3 – Free female connector	14
	Figure 4 – Mounting drawing.....	15
	Figure 5 – Gauge.....	15
	Table 1 – Climatic categories - selected values for environmental performance level 1.....	9
	Table 2 – Clearance and creepage distances.....	10
	Table 3 – Dimensions of the fixed connector.....	13
	Table 4 – Dimensions of the free connector	14
	Table 5 – Mounting information.....	15
	Table 6 – Gauge dimensions	16

Table 7 – Number of test specimens and contacts	20
Table 8 – Test group P	20
Table 9 – Test group AP	21
Table 10 – Test group BP	22
Table 11 – Test group CP	23
Table 12 – Test group DP	24
Table 13 – Test group EP	24
Table 14 – Test group FP	25
Table 15 – Test group JP	25
Table 16 – Test group KP	26

iTeh STANDARD PREVIEW
(standards.iteh.ai)

[IEC 61076-3-118:2010](#)

<https://standards.iteh.ai/catalog/standards/sist/3bc8e8be-26bb-4470-a2d2-55478240ff39/iec-61076-3-118-2010>

INTERNATIONAL ELECTROTECHNICAL COMMISSION

**CONNECTORS FOR ELECTRONIC EQUIPMENT –
PRODUCT REQUIREMENTS –**
**Part 3-118: Rectangular connectors – Detail specification for
a 4 pole plus PE power connector with push-pull coupling**

FOREWORD

- 1) The International Electrotechnical Commission (IEC) is a worldwide organization for standardization comprising all national electrotechnical committees (IEC National Committees). The object of IEC is to promote international co-operation on all questions concerning standardization in the electrical and electronic fields. To this end and in addition to other activities, IEC publishes International Standards, Technical Specifications, Technical Reports, Publicly Available Specifications (PAS) and Guides (hereafter referred to as "IEC Publication(s)"). Their preparation is entrusted to technical committees; any IEC National Committee interested in the subject dealt with may participate in this preparatory work. International, governmental and non-governmental organizations liaising with the IEC also participate in this preparation. IEC collaborates closely with the International Organization for Standardization (ISO) in accordance with conditions determined by agreement between the two organizations.
- 2) The formal decisions or agreements of IEC on technical matters express, as nearly as possible, an international consensus of opinion on the relevant subjects since each technical committee has representation from all interested IEC National Committees.
- 3) IEC Publications have the form of recommendations for international use and are accepted by IEC National Committees in that sense. While all reasonable efforts are made to ensure that the technical content of IEC Publications is accurate, IEC cannot be held responsible for the way in which they are used or for any misinterpretation by any end user.
- 4) In order to promote international uniformity, IEC National Committees undertake to apply IEC Publications transparently to the maximum extent possible in their national and regional publications. Any divergence between any IEC Publication and the corresponding national or regional publication shall be clearly indicated in the latter.
- 5) IEC itself does not provide any attestation of conformity. Independent certification bodies provide conformity assessment services and, in some areas, access to IEC marks of conformity. IEC is not responsible for any services carried out by independent certification bodies.
- 6) All users should ensure that they have the latest edition of this publication.
- 7) No liability shall attach to IEC or its directors, employees, servants or agents including individual experts and members of its technical committees and IEC National Committees for any personal injury, property damage or other damage of any nature whatsoever, whether direct or indirect, or for costs (including legal fees) and expenses arising out of the publication, use of, or reliance upon, this IEC Publication or any other IEC Publications.
- 8) Attention is drawn to the Normative references cited in this publication. Use of the referenced publications is indispensable for the correct application of this publication.
- 9) Attention is drawn to the possibility that some of the elements of this IEC Publication may be the subject of patent rights. IEC shall not be held responsible for identifying any or all such patent rights.

International Standard IEC 61076-3-118 has been prepared by subcommittee 48B: Connectors, of IEC technical committee 48: Electromechanical components and mechanical structures for electronic equipment.

The text of this standard is based on the following documents:

FDIS	Report on voting
48B/2134/FDIS	48B/2175/RVD

Full information on the voting for the approval of this standard can be found in the report on voting indicated in the above table.

This publication has been drafted in accordance with the ISO/IEC Directives, Part 2.

A list of all parts of IEC 61076 series, under the general title *Connectors for electronic equipment – Product requirements*, can be found on the IEC website.

The committee has decided that the contents of this publication will remain unchanged until the stability date indicated on the IEC web site under "<http://webstore.iec.ch>" in the data related to the specific publication. At this date, the publication will be

- reconfirmed,
- withdrawn,
- replaced by a revised edition, or
- amended.

iTeh STANDARD PREVIEW (standards.iteh.ai)

[IEC 61076-3-118:2010](#)

<https://standards.iteh.ai/catalog/standards/sist/3bc8e8be-26bb-4470-a2d2-55478240f39/iec-61076-3-118-2010>

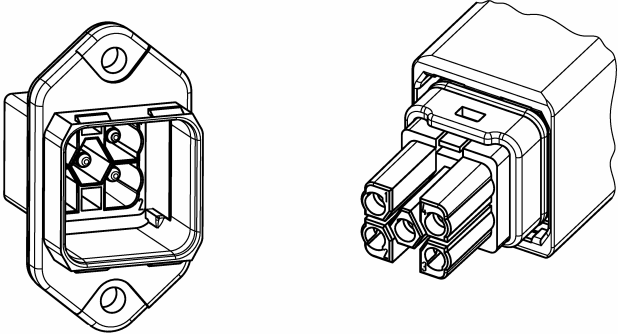
<p>IEC SC 48B – Connector Specifications available from: IEC General secretariat or from the addresses shown on the inside cover.</p>	<p>IEC 61076-3-118 Ed. 1.0</p>
<p>ELECTRONIC COMPONENTS DETAIL SPECIFICATION in accordance with IEC 61076-1 and IEC 61076-3</p>	
<p>Outline drawing</p>  <p>Rectangular power connector with push-pull coupling</p> <p>iTeh STANDARD PREVIEW (standards.iteh.ai)</p>	
<p>IEC 61076-3-118:2010 https://standards.iteh.ai/catalog/standards/sist/3bc8e8bc-26bb-4477-b071-55478240f39/iec-61076-3-118-2010</p>	
<p>Fixed and free connectors, for industrial environments</p>	<p>Performance level: 1</p>

CONNECTORS FOR ELECTRONIC EQUIPMENT – PRODUCT REQUIREMENTS –

Part 3-118: Rectangular connectors – Detail specification for a 4 pole plus PE power connector with push-pull coupling

1 Scope

1.1 General considerations

This part of IEC 61076 establishes specifications and test requirements for a connector with four contacts plus PE contact, for use in industrial environments.

NOTE For a definition of PE, see IEC, for example IEC 195-02-09.

This International Standard specifies free and fixed connectors, with round contacts, suitable for screw or crimp terminations. Other terminations techniques, as solder or printed board connections are upon agreement between manufacturer and user. The free and fixed connectors have a push-pull locking mechanism for IP65 and IP67 protection according to IEC 60529.

The PE contact is first-make last-break.

Connectors according this International Standard are without breaking capacity COC according to IEC 61984, therefore they are not intended to be engaged or disengaged in normal use when live or under load, if not otherwise specified by the manufacturer.

1.2 Normative references

The following referenced documents are indispensable for the application of this document. For dated references, only the edition cited applies. For undated references, the latest edition of the referenced document (including any amendments) applies.

IEC 60050-581:2008, *International Electrotechnical Vocabulary – Part 581: Electro-mechanical components for electronic equipment*

IEC 60068-1: *Environmental testing – Part 1: General and guidance*

IEC 60352 (all parts): *Solderless connections*

IEC 60512-1-2:2002, *Connectors for electronic equipment – Tests and measurements – Part 1-2: General examination*

IEC 60512-1-100: *Connectors for electronic equipment – Tests and measurements – Part 1-100: General: Applicable publications*

IEC 60529:1989, *Degree of protection provided by enclosures (IP Code)*

IEC 60999-1:1999, *Connecting devices – Electrical copper conductors – Safety requirements for screw-type and screwless-type clamping units – Part 1: General requirements and particular requirements for conductors from 0,2 mm² up to 35 mm² (included)*

IEC 60999-2:2003, *Connecting devices – Electrical copper conductors – Safety requirements for screw-type and screwless-type clamping units – Part 2: Particular requirements for clamping units for conductors above 35 mm² up to 300 mm² (included)*

IEC 61076-1, *Connectors for electronic equipment – Part 1: Generic specification*

IEC 61984:2008, *Connectors – Safety requirements and tests*

IEC 62197-1:2006, *Connectors for electronic equipment – Quality assessment requirements – Part 1: Generic specification*

IEC Guide 109: *Environmental aspects – Inclusion in electrotechnical product standards*

IEC Guide 114: *Environmentally conscious design – Integrating environmental aspects into design and development of electrotechnical products*

ISO 1302:2002, *Geometrical Product Specifications (GPS) – Indication of surface texture in technical product documentation*

ISO 11469:2000, *Plastics – Generic identification and marking of plastic products*

2 Technical information

2.1 Terms and definitions

For the purposes of this document, the terms and definitions given in IEC 60050-581 apply.

2.2 Systems of levels

2.2.1 Performance levels

Performance level for this connector is 1.

2.2.2 Compatibility levels, according to IEC 61076-1 Ed. 2.0

Connectors according to this standard are supposed to be intermateable.

2.3 Classification into climatic categories

Conditions: according to IEC 60068-1 and Table 1.

Table 1 – Climatic categories - selected values for environmental performance level 1

Climatic category	Lower temperature °C	Upper temperature °C	Damp heat steady state (days)
40/125/21	–40	125	21

2.4 Clearance and creepage distances

Clearance and creepage distances shall be measured according to IEC 60512-1-2 with the following additional requirements.

For this connector clearance and creepage distances shall be measured only in mated position (connector without breaking capacity as defined in IEC 61984).

The connector has protection against electric shock by finger safety (IP2X or IPXXB), both in the mated or unmated condition, after mounting (see also 6.4.2.2 of IEC 61984). The minimum values for clearance and creepage distances can be found in Table 2.

Table 2 – Clearance and creepage distances

Dimensions in mm

Minimum distance between contacts and earth contact		Minimum distance between adjacent contacts	
Creepage	Clearance	Creepage	Clearance
4	3	6,3	3

2.5 Current-carrying capacity

The current-carrying capacity shall be measured according to IEC 60512, Test 5b and stated by the manufacturer.

2.6 Marking

The marking of the connector and the package shall be in accordance with 2.7 of IEC 61076-1.

The position of the contacts shall be identified by suitable marking. The contact marking shall be on the termination side of the connector (or the connector insert) as long as the size of the component allows the placement there.

3 Dimensional information [IEC 61076-3-118:2010](https://standards.iteh.ai/catalog/standards/sist/3bc8e8be-26bb-4470-a2d2-55478240f39/iec-61076-3-118-2010)

<https://standards.iteh.ai/catalog/standards/sist/3bc8e8be-26bb-4470-a2d2-55478240f39/iec-61076-3-118-2010>

3.1 General

Dimensions are given in millimetres, drawings are shown in first angle projection. The shape of the connectors may deviate from those given in the following drawings as long as the specified dimensions are not influenced.

The following requirements apply to the complete connector consisting of both the free and fixed connectors.

For safety aspects IEC 61984 shall be considered unless otherwise specified.

Missing dimensions shall be chosen according to the common characteristics and intended use. The interface dimensions of the female style shall be chosen according to the common characteristics of the male styles.

3.2 Isometric view and common features

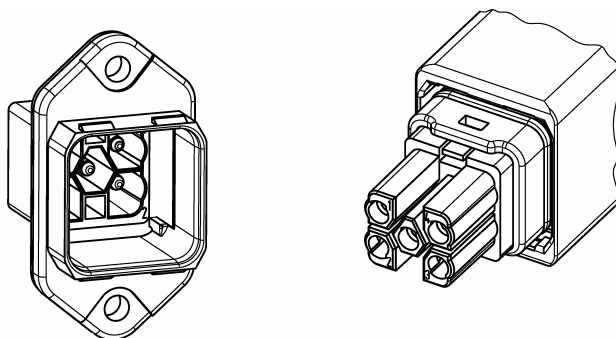

IEC 673/10

NOTE Male connectors according to this IS are those connectors having a male electric part.

Figure 1 – Fixed (male) and free (female) connector

3.2.1 Common features

Not applicable.

3.2.2 Reference system

No special reference system is applied.

3.3 Engagement (mating) information

3.3.1 Engaging (mating) direction

Not applicable.

IEC 61076-3-118:2010
<https://standards.iteh.ai/catalog/standards/sist/3bc8e8be-26bb-4470-a2d2-55478240f39/iec-61076-3-118-2010>

3.3.1.1 Contact levels and sequencing

The PE contact is first-make last-break. All other contacts have the same contact level.

3.3.2 Perpendicular to the engaging (mating) direction

Not applicable

3.3.3 Inclination

Not applicable.

3.4 Fixed connectors

3.4.1 Dimensions

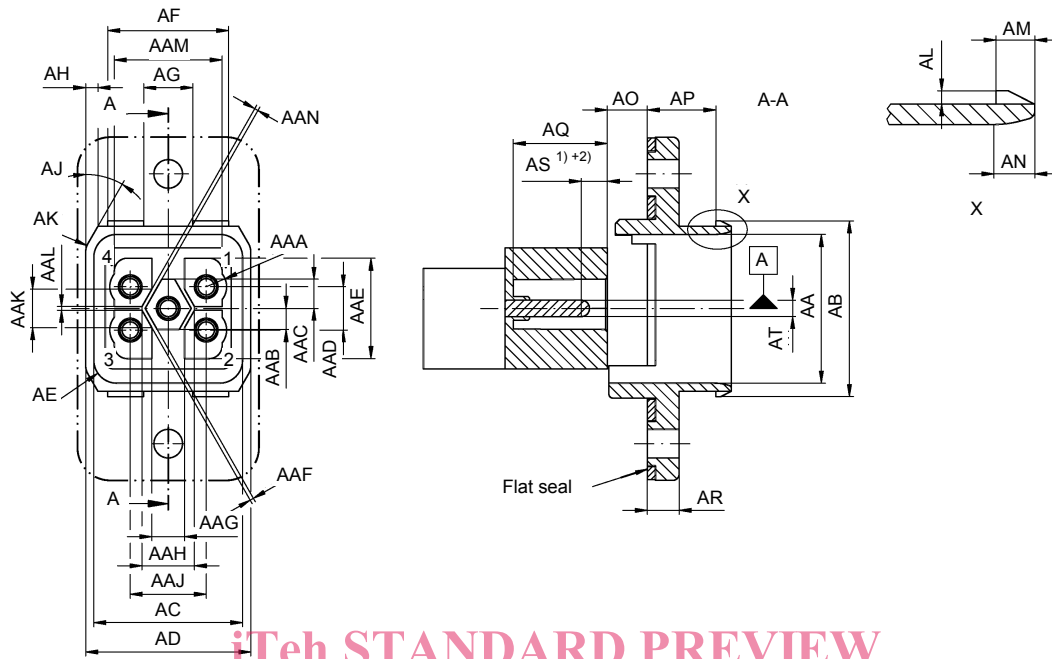

STANDARD PREVIEW
(standards.iteh.ai)

IEC 674/10

NOTE 1 AS1 for PE contact.

NOTE 2 AS2 for power contacts 1-4.

IEC 61076-3-118:2010
Figure 2 – Fixed male connector
<https://standards.iteh.ai/catalog/standards/sist/61076-3-118-2010/61076-3-118-2010>

Table 3 – Dimensions of the fixed connector*Dimensions in mm*

Letter	Maximum	Minimum	Nominal
AA	18,23	18,17	18,2
AB	21,55	21,45	21,5
AC	18,23	18,17	18,2
AD	20,3	20,1	20,2
AE	2,83	2,77	2,8
AF	14,85	14,75	14,8
AG	6,05	5,95	6
AH	1,7	1,3	1,5
AJ	31	29	30
AK	2,1	1,9	2
AL	0,7	0,6	0,65
AM	1,95	1,85	1,9
AN	2,1	1,9	2
AO	5,1	4,9	5
AP	8,35	8,25	8,3
AQ	11,55	11,45	11,5
AR	3,9	3,7	3,8
AS1	3,35	2,95	3,15
AS2	4,55	4,15	4,35
AT	2,5478240#39/iee-61076-3-118-2010	1,96	2
AAA	2,55	2,45	2,5
AAB	2,7	2,6	2,6
AAC	3,7	3,6	3,6
AAD	5,35	5,25	5,3
AAE	12,4	12,3	12,3
AAF	0,5	0,4	0,45
AAG	4	3,9	4
AAH	6,4	6,3	6,4
AAJ	9,35	9,25	9,3
AAK	4,7	4,6	4,7
AAL	0,5	0,4	0,45
AAM	13,3	13,2	13,2
AAN	0,5	0,4	0,45
NOTE 1 AS1 for PE contact.			
NOTE 2 AS2 for power contacts 1-4.			

3.4.2 Terminations

Terminations according to IEC 61984, 6.6.

NOTE Other technologies such as printed-board terminations could be applied upon agreement between manufacturer and customer.