

**SLOVENSKI STANDARD  
SIST EN 3288:2001****01-januar-2001**

---

**Aerospace series - Bearings, airframe rolling - Double row self-aligning ball bearings in steel, cadmium plated - Diameter series 2 - Dimensions and loads**

Aerospace series - Bearings, airframe rolling - Double row self-aligning ball bearings in steel, cadmium plated - Diameter series 2 - Dimensions and loads

Luft- und Raumfahrt - Flugwerkklager - Zweireihige Pendelkugellager aus Stahl, verkadmet - Durchmesserreihe 2 - Maße und Belastungen

Série aérospatiale - Roulements pour structures d'aéronefs - Roulements en acier, cadmiés, à rotule, sur deux rangées de billes - Série de diamètres 2 - Dimensions et charges

<https://standards.iteh.ai/catalog/standards/sist/ccaf7d29-e42a-4bbf-a251-e1a367acb916/sist-en-3288-2001>

**Ta slovenski standard je istoveten z: EN 3288:1994****ICS:**

49.035	Sestavni deli za letalsko in vesoljsko gradnjo	Components for aerospace construction
--------	--	---------------------------------------

**SIST EN 3288:2001****en**

**iTeh STANDARD PREVIEW**  
**(standards.iteh.ai)**

SIST EN 3288:2001

<https://standards.iteh.ai/catalog/standards/sist/ccaf7d29-e42a-4bbf-a251-e1a367acb916/sist-en-3288-2001>

EUROPEAN STANDARD

EN 3288

NORME EUROPÉENNE

EUROPÄISCHE NORM

May 1994

UDC 629.7.02:681.822.7.004.1:681.828:669.14:669.738

Descriptors: Aircraft industry, airframe bearings, self-aligning bearings, ball bearings, steel, cadmium, dimensions, static loads

English version

**Aerospace series - Bearings, airframe rolling -  
Double row self-aligning ball bearings in steel,  
cadmium plated - Diameter series 2 - Dimensions  
and loads**

Série aérospatiale - Roulements pour structures d'aéronefs - Roulements en acier, cadmiés, à rotule, sur deux rangées de billes - Série de diamètres 2 - Dimensions et charges

ITIH STANDARD PREVIEW  
(standards.iteh.a)

Luft- und Raumfahrt - Flugwerklager - Zweireihige Pendelkugellager aus Stahl, vercadmet - Durchmesserreihe 2 - Maße und Belastungen

SIST EN 3288:2001

<https://standards.iteh.ai/catalog/standards/sist/ecaf7d29-e42a-4bbf-a251-e1a367acb916/sist-en-3288-2001>

This European Standard was approved by CEN on 1994-05-19. CEN members are bound to comply with the CEN/CENELEC Internal Regulations which stipulate the conditions for giving this European Standard the status of a national standard without any alteration.

Up-to-date lists and bibliographical references concerning such national standards may be obtained on application to the Central Secretariat or to any CEN member.

The European Standards exist in three official versions (English, French, German). A version in any other language made by translation under the responsibility of a CEN member into its own language and notified to the Central Secretariat has the same status as the official versions.

CEN members are the national standards bodies of Austria, Belgium, Denmark, Finland, France, Germany, Greece, Iceland, Ireland, Italy, Luxembourg, Netherlands, Norway, Portugal, Spain, Sweden, Switzerland and United Kingdom.

# CEN

European Committee for Standardization  
Comité Européen de Normalisation  
Europäisches Komitee für Normung

Central Secretariat: rue de Stassart, 36 B-1050 Brussels

Foreword

This European Standard has been prepared by the European Association of Aerospace Manufacturers (AECMA).

After inquiries and votes carried out in accordance with the rules of this Association, this Standard has successively received the approval of the National Associations and the Official Services of the member countries of AECMA, prior to its presentation to CEN.

This standard was submitted for Formal Vote, and the result was positive.

This European Standard shall be given the status of a national standard, either by publication of an identical text or by endorsement, at the latest by November 1994, and conflicting national standards shall be withdrawn at the latest by November 1994.

According to the CEN/CENELEC Internal Regulations, the following countries are bound to implement this European Standard: Austria, Belgium, Denmark, Finland, France, Germany, Greece, Iceland, Ireland, Italy, Luxembourg, Netherlands, Norway, Portugal, Spain, Sweden, Switzerland, United Kingdom.

(standards.iteh.ai)

SIST EN 3288:2001

<https://standards.iteh.ai/catalog/standards/sist/ccaf7d29-e42a-4bbf-a251-12364bb19/Sist-EN-3288-2001>

STANDARD PREVIEW  
SIST EN 3288:2001  
AEROSPACE MANUFACTURERS ASSOCIATION  
EUROPEAN ASSOCIATION OF AEROSPACE MANUFACTURERS  
AECMA

.....T010  
BVT0ALETAN IC0010 09 T8LV088

## 1 Scope

This standard specifies the characteristics of double row self-aligning ball bearings in steel <sup>1)</sup>, cadmium plated, of diameter series <sup>2)</sup> designed to withstand only slow rotations, oscillations and/or swivelling under load.

They are intended for use between fixed and moving parts of the aircraft structure and their control mechanisms.

The airframe rolling bearings defined in this standard are used from – 54 °C to + 150 °C.

However, being lubricated with the following greases :

- very high pressure grease, ester type (code A), operational range – 73 °C to + 121 °C or
- very high pressure grease, synthetic hydrocarbons, general purpose (code B), operational range – 54 °C to + 177 °C (see EN 3280),

their field of application when lubricated with code A grease is limited to + 121 °C.

## 2 Normative references

This European Standard incorporates by dated or undated reference provisions from other publications. These normative references are cited at the appropriate places in the text and the publications are listed hereafter. For dated references, subsequent amendments to or revisions of any of these publications apply to this European Standard only when incorporated in it by amendment or revision. For undated references the latest edition of the publication referred to applies.

ISO 15	Rolling bearings - Radial bearings - Boundary dimensions - General plan
ISO 1132	Rolling bearings - Tolerances - Definitions
EN 2031	Steel FE-PL31 - Hardened and tempered - Bars - Aerospace series <sup>3)</sup>
EN 2133	Cadmium plating of steels with maximum specified tensile strength equal to or less than 1450 MPa and copper and copper alloys - Aerospace series <sup>3)</sup>
EN 2221	Steel FE-PL31 - Hardened and tempered - Hollow bars $3,5 \text{ mm} \leq a \leq 55 \text{ mm}$ - Aerospace series <sup>3)</sup>
EN 2222	Steel FE-PL31 - Hardened and tempered - Hand and die forgings - Aerospace series <sup>3)</sup>
EN 3280	Aerospace series - Bearings, airframe rolling, rigid or self-aligning - Technical specification
EN 3289	Aerospace series - Bearings, airframe rolling - Double row self-aligning ball bearings in corrosion resisting steel - Diameter series 2 - Dimensions and loads

[SIST EN 3288:2001](https://standards.iteh.ai/catalog/standards/sist/ccaf7d29-e42a-4bbf-a251-e1a367acb916/sist-en-3288-2001)

<https://standards.iteh.ai/catalog/standards/sist/ccaf7d29-e42a-4bbf-a251-e1a367acb916/sist-en-3288-2001>

## 3 Definition

For the purposes of this standard, the following definition applies :

**Bearing** : full complement of balls (without cage).

## 4 Symbols

The definitions of tolerances and clearances are given in ISO 1132.

$\Delta_{dmp}$	= single plane mean bore diameter deviation
$\Delta_{Dmp}$	= single plane mean outside diameter deviation
$\Delta_{ds}$	= deviation of a single bore diameter
$\Delta_{Ds}$	= deviation of a single outside diameter
$G_a$	= axial internal clearance
$G_r$	= radial internal clearance
$K_{ia}$	= radial runout of assembled bearing inner ring
$K_{oa}$	= radial runout of assembled bearing outer ring
$F_a \text{ max.}$	= permissible static axial load
$C_s$	= permissible static radial load
$P_{or}$	= static equivalent radial load
$F_a$	= bearing axial load, axial component of actual bearing load
$F_r$	= bearing radial load, radial component of actual bearing load.

1) For new design, use preferably bearings in corrosion resisting steel, see EN 3289

2) See ISO 15

3) Published as AECMA Standard at the date of publication of this standard

## 5 Required characteristics

### 5.1 Dimensions - Tolerances - Clearances - Loads - Mass

Configuration : see figure 1 ; the bearings are fitted with either seals or shields.

Values : see table 1 ; the dimensions and tolerances apply after protection.

### 5.2 Surface roughness

Raceways and rolling elements :  $R_a = 0,2 \mu\text{m}$

Bore, side faces and cylindrical outer surface :  $R_a = 0,8 \mu\text{m}$

The values apply prior to cadmium plating.

### 5.3 Materials

Inner ring : EN 2031 or EN 2221 or EN 2222, 59 HRC to 64 HRC

Outer ring : EN 2031 or EN 2221 or EN 2222, 59 HRC to 64 HRC

Balls : EN 2031, 59 HRC to 64 HRC

Shields : Corrosion resisting material

Seals : Polytetrafluoroethylene (PTFE) or polytetrafluoroethylene (PTFE) reinforced with fibreglass.

### 5.4 Surface treatment

EN 2133 thickness,  $5 \mu\text{m}$  to  $12 \mu\text{m}$ , on the inner and outer rings, the bore and raceways are not cadmium plated.

As soon as possible after plating, and within 16 h de-embrittlement heat treatment shall be carried out at a temperature and for a time (compatible with the performance requirements of the bearing) which shall be subject to written approval of the qualifying authorities.

**iTeh STANDARD PREVIEW**  
(standards.iteh.ai)

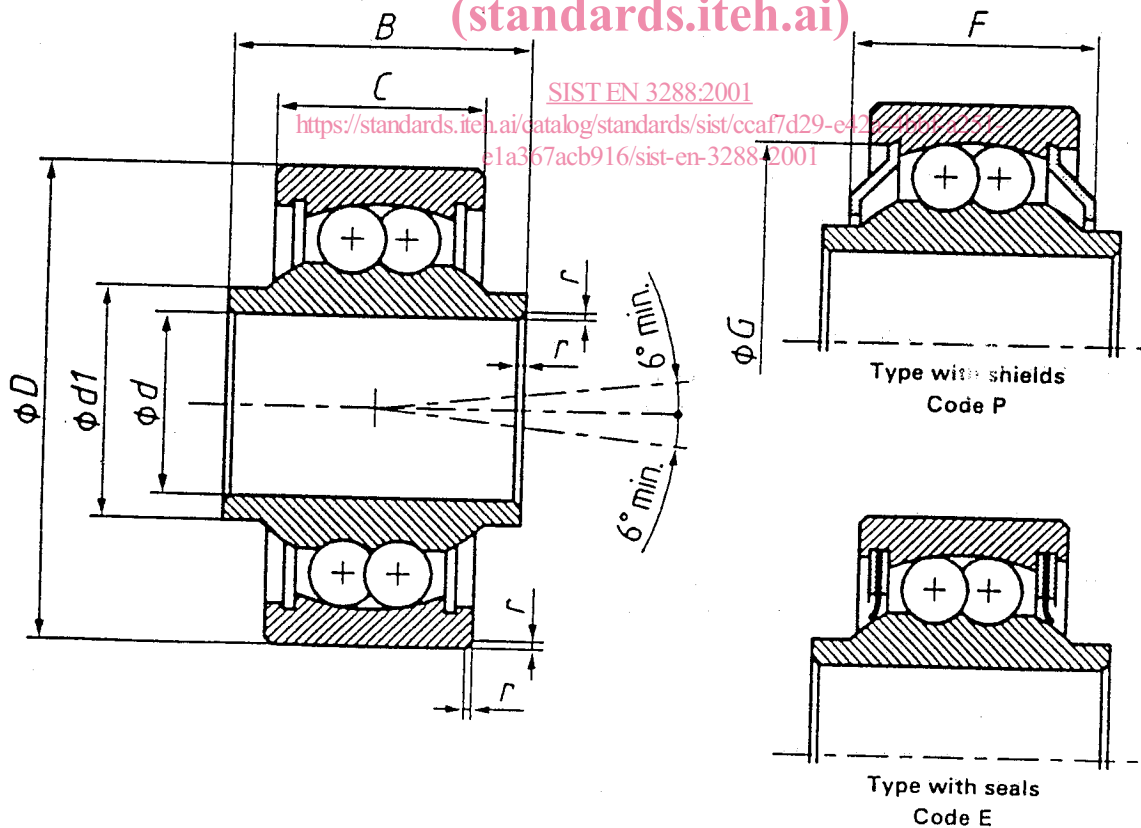

NOTE : The installation of seals and shields is at the manufacturer's option.

Figure 1

Table 1

Dimensions in millimetres

d		B	C	D	d1	F	G	Tolerances $\mu\text{m}$				r	Mass kg/1000 parts $\approx$		
Code	Nominal	0 - 0,12	0 - 0,12		min.	max. 1)	max. 1)	$\Delta_{\text{dmp}}$	$\Delta_{\text{Dmp}}$	$\Delta_{\text{ds}}$	$\Delta_{\text{Ds}}$				
05	5	12	8	16	7,6	10	12	0 - 8	0 - 8	+ 2 - 10	+ 2 - 11	0,3 to 0,8	9		
06	6	14	10	19	8,6	12	14,4		0 - 9				+ 2 - 10	+ 2 - 11	14
08	8	15		24	11,1	13	19,8								0 - 11
10	10	20	14	30	13,6	24	0 - 11		+ 3 - 11				+ 3 - 14	57	
12	12			32	15,4	17				26,5	62				
15	15			35	18,5	30				75					
17	17	22	16	40	21,2	19	34		0 - 11	+ 3 - 13			110		
20	20	24	18	47	23,6	20	39,7						0 - 10		

iTeh STANDARD PREVIEW

(standards.itech.ai)

d	Internal clearances $\mu\text{m}$						Runout tolerances radial max. $\mu\text{m}$		Starting torque <sup>2)</sup> in mN.m		Permissible static loads <sup>3)</sup> kN	
	Axial max. $G_a$			Radial $G_r$			$K_{ia}$	$K_{ea}$	Code P	Code E	Axial $F_a$ max.	Radial $C_s$
	Special group Code R	Normal group Code N	Group 3 Code L	Special group Code R	Normal group Code N	Group 3 Code L						
05	70	100		2 to 6	2 to 13	10 to 20	25	40	4	8	1,2	3,7
06				4,5					9	1,8	5,7	
08	5,5			10	2,8	9,1						
10	7,5			12	4,4	14,1						
12	9	14	5	16,1								
15	12	18	5,9	18,8								
17	18	25	7,6	24,3								
20	23	35	10,2	32,6								

1) Dimensions of the shields are at the manufacturer's option within the limits of F and G.  
2) Definition, see EN 3280  
3)  $F_r + 3,2 F_a = P_{or}$ ;  $P_{or}$  shall be  $\leq C_s$ .  
For ultimate static loads, see EN 3280.

## 6 Designation

EXAMPLE :

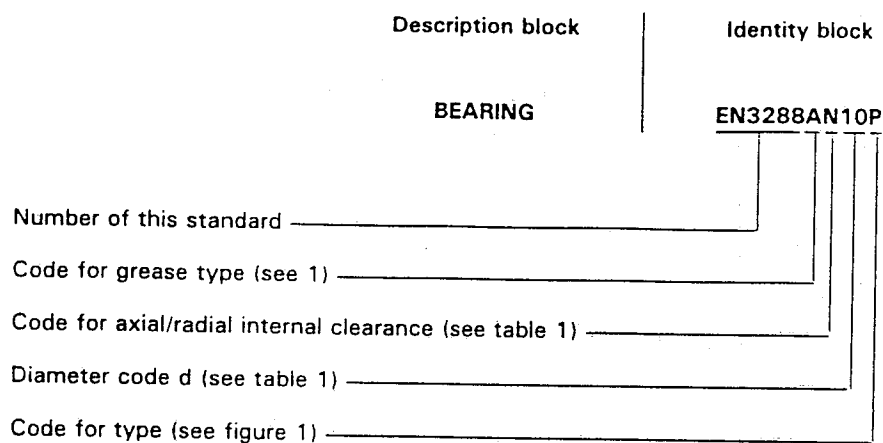

NOTE : If necessary, the code I9005 shall be placed between the description block and the identity block.

## 7 Marking

In addition to the manufacturer's own marking, each bearing shall be marked, on one side face only, using the identity block, see 6.

Marking position and method are at the manufacturer's option.

**ITeH STANDARD PREVIEW**  
(standards.iteh.ai)

[SIST EN 3288:2001](https://standards.iteh.ai/catalog/standards/sist/ccaf7d29-e42a-4bbf-a251-e1a367acb916/sist-en-3288-2001)

<https://standards.iteh.ai/catalog/standards/sist/ccaf7d29-e42a-4bbf-a251-e1a367acb916/sist-en-3288-2001>

## 8 Technical specification

See EN 3280.