

# INTERNATIONAL STANDARD

ISO  
8917

First edition  
1988-12-15



---

INTERNATIONAL ORGANIZATION FOR STANDARDIZATION  
ORGANISATION INTERNATIONALE DE NORMALISATION  
МЕЖДУНАРОДНАЯ ОРГАНИЗАЦИЯ ПО СТАНДАРТИЗАЦИИ

---

## Light olefins for industrial use — Determination of water — Guidelines for use of in-line analysers

*Oléfines légères à usage industriel — Dosage de l'eau — Directives pour l'utilisation  
d'analyseurs en ligne*

**(standards.iteh.ai)**

ISO 8917:1988

<https://standards.iteh.ai/catalog/standards/sist/b5688e95-1608-4f31-83cb-63cee13b45f2/iso-8917-1988>

Reference number  
ISO 8917: 1988 (E)

## Foreword

ISO (the International Organization for Standardization) is a worldwide federation of national standards bodies (ISO member bodies). The work of preparing International Standards is normally carried out through ISO technical committees. Each member body interested in a subject for which a technical committee has been established has the right to be represented on that committee. International organizations, governmental and non-governmental, in liaison with ISO, also take part in the work. ISO collaborates closely with the International Electrotechnical Commission (IEC) on all matters of electrotechnical standardization.

Draft International Standards adopted by the technical committees are circulated to the member bodies for approval before their acceptance as International Standards by the ISO Council. They are approved in accordance with ISO procedures requiring at least 75 % approval by the member bodies voting.

International Standard ISO 8917 was prepared by Technical Committee ISO/TC 47, *Chemistry*.

[ISO 8917:1988](https://standards.iteh.ai/catalog/standards/sist/b5688e95-1608-4f31-83cb-63cee13b45f2/iso-8917-1988)

Annex A of this International Standard is for information only

## Introduction

The exact determination of traces of water in gases is one of the most difficult analytical problems. This is due to the high tendency of the highly polar water molecules to adsorb on any glass or metal surface. Discontinuous sampling in sampling cylinders shall therefore be strictly avoided. The only solution to this problem is the continuous measurement by an in-line sensor in the continuous streaming sample gas flow.

## iTeh STANDARD PREVIEW (standards.iteh.ai)

[ISO 8917:1988](https://standards.iteh.ai/catalog/standards/sist/b5688e95-1608-4f31-83cb-63cee13b45f2/iso-8917-1988)

<https://standards.iteh.ai/catalog/standards/sist/b5688e95-1608-4f31-83cb-63cee13b45f2/iso-8917-1988>

**iTeh STANDARD PREVIEW**  
**(standards.iteh.ai)**

This page intentionally left blank

ISO 8917:1988

<https://standards.iteh.ai/catalog/standards/sist/b5688e95-1608-4f31-83cb-63cee13b45f2/iso-8917-1988>

# Light olefins for industrial use — Determination of water — Guidelines for use of in-line analysers

## 1 Scope

This International Standard gives methods for the determination of traces of water using an analyser with an in-line sensor in flows of gaseous light olefins. These flows may come from a sample line or from a capillary tube for vaporization of liquid samples at high pressures (see ISO 6377) or at low temperatures.

The instructions for use of these analysers do not differ from those used in gases such as hydrogen, nitrogen, oxygen, methane, ethylene, etc.

This International Standard does not describe the methods of sampling or analysis of individual gaseous samples. In addition it does not give a description of discontinuous measurement such as gravimetry, Karl Fischer titration (see ISO 6191), gas chromatography (see ISO 6977), etc.

It compiles the various principles of working of the most generally used commercial analysers.<sup>1)</sup>

## 2 Normative references

The following standards contain provisions which, through reference in this text, constitute provisions of this International Standard. At the time of publication, the editions indicated were valid. All standards are subject to revision, and parties to agreements based on this International Standard are encouraged to investigate the possibility of applying the most recent editions of the standards listed below. Members of IEC and ISO maintain registers of currently valid International Standards.

ISO 2202 : 1972, and ISO 2202/Add.1 : 1975, *Liquid chlorine for industrial use — Determination of water content using an electrolytic analyser*.

ISO 6147 : 1979, *Gas analysis — Preparation of calibration gas mixtures — Saturation method*.

ISO 6349 : 1979, *Gas analysis — Preparation of calibration gas mixtures — Permeation method*.

ISO 6377 : 1981, *Light olefins for industrial use — Determination of impurities by gas chromatography — General considerations*.

ISO 7382 : 1986, *Ethylene for industrial use — Sampling in the liquid and the gaseous phase*.

## 3 Working principles and general characteristics of various analysers

### 3.1 Electrolytic decomposition

Two thin platinum wires wound as parallel spirals on a glass rod are covered with a phosphorus pentoxide film. This rod is introduced into a glass tube, through which the gaseous current flows (see ISO 2202 and ISO 2202/Add. 1).

The absorption of water by phosphorus pentoxide at the recommended flow rates is quantitative. The phosphoric acid formed causes an electrical conductance between the two platinum wires placed under an external applied voltage. This is sufficient for a complete electrolytic decomposition of the absorbed water. From the measured current and the measured gaseous flow rate, the moisture content is calculated, using Coulomb's law.

Measuring range: 0 to 1 000 ml of water (gaseous) per cubic metre.

Advantage:

- corrosion resistant.

Disadvantages:

- not suitable for olefins  $\geq C_3$  which can polymerize under the influence of strong acids;
- not suitable for gas mixtures containing traces of ammonia, which give the same signal as water.

1) Details of commercially available instruments can be obtained from the ISO Central Secretariat or from the Secretariat of ISO/TC 47/SC 14 (AFNOR).

### 3.2 Light reflection on a cooled mirror (dew-point)

A mirror in contact with the gas stream is slowly cooled, either by dry ice, or electrically by a Peltier effect cell. Simultaneously, both the temperature of the mirror and its reflection are recorded, possibly automatically. At the dew-point, the reflection of light begins to be disturbed.

Measuring range indicated by the manufacturer: 30 ml to 500 000 ml of water per cubic metre.

Advantages :

- strongly built, corrosion-resistant apparatus;
- calibration unnecessary;
- verification of one fixed point is sufficient to check the reliability over the whole measuring range.

Disadvantages :

- the mirror can be soiled;
- dew-points other than that of water can be created, especially for olefins  $> C_3$ ;
- long waiting times;
- large quantities of sample gas are needed to obtain a stable indication, especially in the case of low water contents.

### 3.3 Modification of vibration frequency of a quartz crystal covered with a hygroscopic layer

The adsorption of water on a hygroscopic layer deposited on a quartz crystal increases the mass of this entire unit and consequently decreases its own vibration frequency. Due to the possibility of digital counting of the frequencies, sensitive and specific water content determinations are possible. By automatic and periodic inversions of sample and standard gas currents, there is a permanent internal calibration.

Measuring range: 0 to 25 000 ml of water per cubic metre.

Advantages :

- large measuring range;
- applicable to all olefins;
- corrosion resistant.

Disadvantages :

- large quantities of sample and standard gas;
- sensitivity to interference by ammonia;
- soiling of the crystal surface by dirt particles.

### 3.4 Variation of the capacity of a capacitor formed by a hygroscopic dielectric polymer and two porous electrodes

The capacitor consists of a foil of a hygroscopic polymer with two porous electrodes formed by depositing evaporated gold as thin films on either side. This polymer material is in equilibrium with the moisture in the adjacent gaseous phase outside. The oscillating frequency of a circuit containing this capacitor is measured electronically.

Measuring range indicated by manufacturer: 120 ml to 10 000 ml of water per cubic metre.

Advantages: cheap, strongly built, corrosion-resistant apparatus.

Disadvantages :

- not very sensitive;
- unstable calibration.

### 3.5 Infrared spectrometry

Two variants may be used :

- a) direct measurement of the absorption;
- b) sequential measuring by comparing the absorption of the heated water with the absorption after passage through a calibration gas cuvette (URAS principle)

Indicated measuring range: 10 ml to 1 000 000 ml of water per cubic metre (with a heated cell).

Advantages :

- quick measurement;
- sufficiently sensitive;
- no interference by ammonia or amines;
- corrosion resistant.

Disadvantages :

- bulky apparatus;
- fairly expensive apparatus, costly for temperature stabilisation;
- not very suitable for in-line analysis in a technical plant.

### 3.6 Micro-wave absorption measurement

This apparatus was originally designed for the measurement of the moisture content of solids. For gaseous samples, it is suitable in principle but is much less sensitive.

Indicated measuring range: 1 000 ml to 1 000 000 ml water per cubic metre.

### 3.7 Variation of the capacity of a capacitor consisting of an aluminium oxide dielectric covered by an evaporated porous gold film

This sensor cell is similar to that mentioned in 3.4, except that the hygroscopic polymer material forming the dielectric is replaced by a thin layer of anodically produced aluminium oxide on an aluminium metal base. An evaporated porous gold film forms the counter electrode. The electronic measurement is identical.

Indicated measuring range: for different instruments, measuring ranges from 0,1 ml to 2 500 ml of water per cubic metre and from 0,01 ml to 200 000 ml of water per cubic metre.

Advantages:

- wide measuring ranges;
- suitable for all olefins;
- stable calibrations, recalibration period 1 month;
- relatively cheap.

Disadvantages:

- not resistant to corrosion;
- interference with ammonia.

## 4 Procedure

### 4.1 Safety measures

The sensor cells of all the above-mentioned analysers work in-line with gaseous currents. In the case of transfer lines, a reinjection is possible and shall be installed. If not, it is necessary to exhaust the sample gas through a suitable ejector to air (see ISO 7382).

### 4.2 Installation and preparation of analysers

The determination, in particular for low water contents, in gases is generally a difficult problem due to the polarity of the water molecules and consequently their extreme adsorption tendency to all polar surfaces, especially glass or metal. In the present case it is necessary that all connection lines be as short as possible. If possible, they should be heated. The gas flow through the sample gas line should be as strong as possible. A stable signal is attained when the adsorption equilibrium between the flowing gas and the tube material has reached the exit of the sensor cell.

Some analyses are carried out with samples liquefied under pressure. In this case, a representative vaporization in a capillary is necessary (see ISO 6377).

The quantity of sample available shall be large enough to purge the cell sufficiently and to maintain a reliably constant signal for at least 2 min. Obviously, the sample gas flow rate shall be in conformity with the recommendations of the manufacturer of the analyser.

It is important that the individual user gets acquainted with the instrument before routine analysis, so he can judge the necessary quantity of the liquid sample.

### 4.3 Calibrations

All the analysers described are calibrated by the manufacturers. However, as they operate according to physico-chemical principles, the checking of these calibrations or even recalibrations may be necessary or at least recommended.

The analysers work in-line. The calibrations shall, of course, also be carried out in-line. It is imperative to have gaseous currents available with well-known and well-checked constant water contents for this calibration or recalibration. Gaseous currents with variations of water content, even if these variations are quantitatively known (for example as a peak with a known area), shall not be used<sup>1)</sup>.

Most of the analysers described give the values on a logarithmic scale<sup>2)</sup>. Consequently the quantitative checking of any peak in a linear scale is not possible.

Because of the adsorption tendency of the water mentioned in 4.2, all static methods for the preparation of gaseous mixtures for calibration shall be excluded. The following dynamic methods may be used.

#### 4.3.1 Saturation method (see ISO 6147)

In operating in accordance with ISO 6147, temperatures greater than or equal to 0 °C can be adjusted in the condenser. This corresponds to water contents greater than or equal to 6 000 ml/m<sup>3</sup>. This content can be reduced by using a cryostat to cool the condenser. Of course, the ice formed shall be removed periodically by warming up the condenser. The water content of the flowing calibration gas can be calculated from the known vapour pressures of ice as a function of temperature.

Alternatively, the streaming gaseous mixture issuing from the apparatus as described in ISO 6147 can be diluted into a second flow of a well-dried (and checked) gas (see ISO 6349 : 1979, figure 3).

#### 4.3.2 Permeation method (see ISO 6349)

Using the method described in ISO 6349, the obtainable water concentrations are between 0,001 ml/m<sup>3</sup> and 10 ml/m<sup>3</sup> with a possible accuracy of  $\pm 2\%$  in relative value. Higher contents can be easily obtained by using a diffusion membrane with a larger surface and/or a higher permeation rate. This can be achieved with a silicone tube coiled and immersed in water at a constant temperature (see figure 1).

1) For example: thermal decomposition of a hydrate salt into a gaseous current.

2) Except the analyser based on the electrolytic decomposition of water after absorption in a phosphorus pentoxide film. In this case, the peak area should be evaluated.

In this case, the permeation rate can be directly evaluated by weighing the whole assembly (see figure 1) after precisely known time-intervals with constant streaming of the gas through this tube.

The intervals shall be at least 24 h and the balance shall be capable of weighing to the nearest  $\pm 50$  mg, for a mass of about 100 g.

#### 4.3.3 Coulometric method after combustion

A measured nitrogen current is introduced into an electrolytic cell containing an aqueous electrolyte. The hydrogen and the oxygen are generated with a measured electrolysis current.

After careful drying, this gaseous current is introduced into a tube filled with a heated catalyst, where the known amounts of hydrogen and oxygen react quantitatively to produce a known amount of water in unit time. The water content in the original nitrogen current can be easily calculated from its flow rate and the electrical current intensity for the electrolysis and by applying Coulomb's law.

#### 4.4 Determination

Use the analyser in accordance with the manufacturer's, instructions, after having checked its operation by recalibrating it.

NOTE — Ammonia and amines may cause interference.

## 5 Expression of results

Express the water content in millilitres per cubic metre.

## 6 Test report

The test report shall include the following information :

- a) identification of the sample;
- b) a reference to the method and the instrument used;
- c) the results and the method of expression used; if necessary, the indication of dew-point and the calculation of the water content;
- d) the details of any operations (temperature, flow rate of gaseous current, pressure, etc.).

**iTeh STANDARD PREVIEW**  
**(standards.iteh.ai)**

[ISO 8917:1988](https://standards.iteh.ai/catalog/standards/sist/b5688e95-1608-4f31-83cb-63cee13b45f2/iso-8917-1988)

<https://standards.iteh.ai/catalog/standards/sist/b5688e95-1608-4f31-83cb-63cee13b45f2/iso-8917-1988>



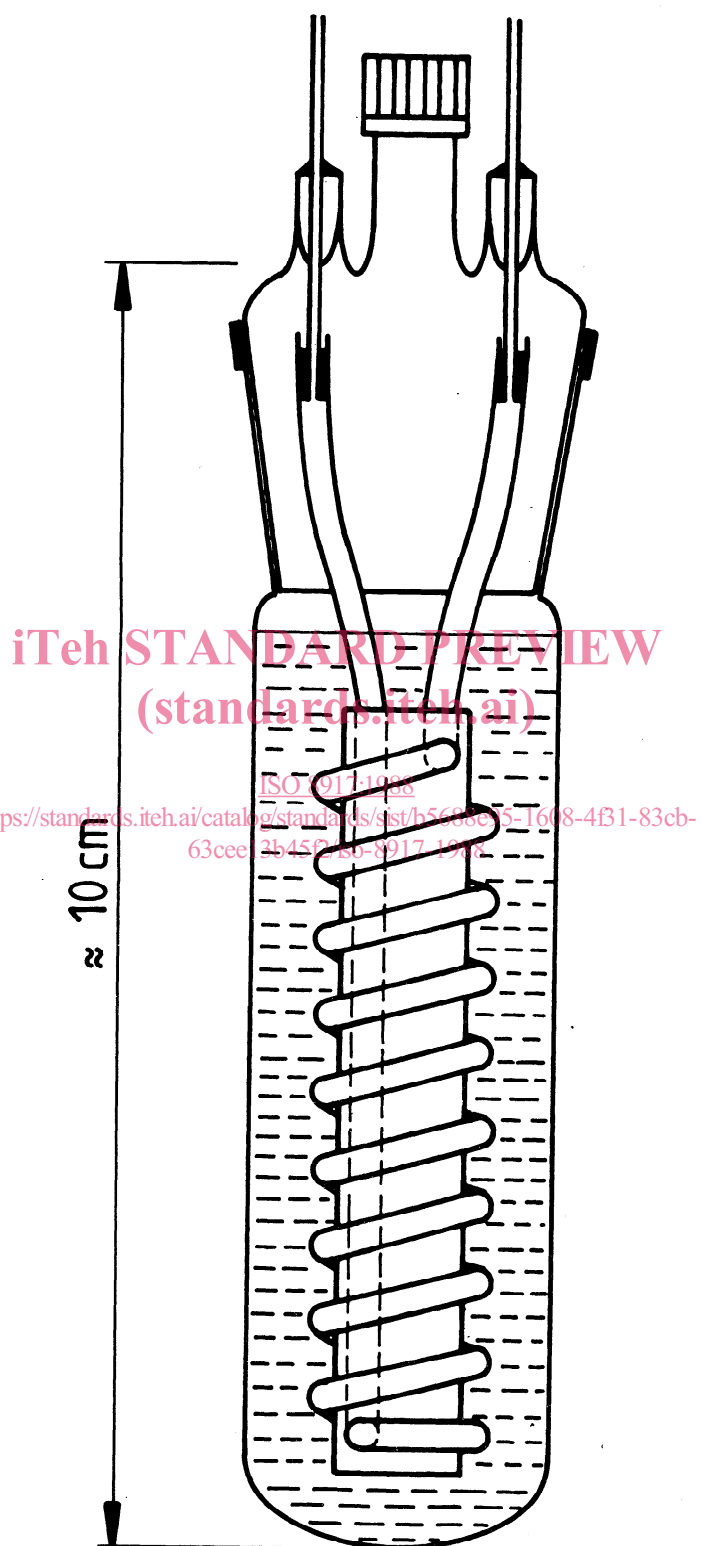

Figure 1 — Humidifier