



SLOVENSKI STANDARD

SIST EN 12808-4:2002

01-november-2002

Lepila in fugirne malte za ploščice - 4. del: Ugotavljanje skrčka----

Grouts for tiles - Part 4: Determination of shrinkage

Klebstoffe und Fugenmörtel für Fliesen und Platten - Teil 4: Bestimmung der Schwindung

Mortiers de joints pour carrelages - Partie 4: Détermination du retrait

(standards.iteh.ai)

Ta slovenski standard je istoveten z: EN 12808-4:2001

<https://standards.iteh.ai/catalog/standards/sist/d516b56a-b58b-4312-b66c-620e818731f6/sist-en-12808-4-2002>

ICS:

83.180	Lepila	Adhesives
91.100.10	Cement. Mavec. Apno. Malta	Cement. Gypsum. Lime. Mortar
91.100.23	Keramične ploščice	Ceramic tiles

SIST EN 12808-4:2002

en

iTeh STANDARD PREVIEW
(standards.iteh.ai)

SIST EN 12808-4:2002

<https://standards.iteh.ai/catalog/standards/sist/d516b56a-b58b-4312-b66c-620e818731f6/sist-en-12808-4-2002>

EUROPEAN STANDARD
NORME EUROPÉENNE
EUROPÄISCHE NORM

EN 12808-4

December 2001

ICS 91.100.10

English version

Grouts for tiles - Part 4: Determination of shrinkage

Mortiers de joints pour carrelages - Partie 4: Détermination
du retrait

Klebstoffe und Fugenmörtel für Fliesen und Platten - Teil 4:
Bestimmung der Schwindung

This European Standard was approved by CEN on 3 November 2001.

CEN members are bound to comply with the CEN/CENELEC Internal Regulations which stipulate the conditions for giving this European Standard the status of a national standard without any alteration. Up-to-date lists and bibliographical references concerning such national standards may be obtained on application to the Management Centre or to any CEN member.

This European Standard exists in three official versions (English, French, German). A version in any other language made by translation under the responsibility of a CEN member into its own language and notified to the Management Centre has the same status as the official versions.

CEN members are the national standards bodies of Austria, Belgium, Czech Republic, Denmark, Finland, France, Germany, Greece, Iceland, Ireland, Italy, Luxembourg, Netherlands, Norway, Portugal, Spain, Sweden, Switzerland and United Kingdom.

STANDARD PREVIEW
(standards.iteh.ai)

SIST EN 12808-4:2002

<https://standards.iteh.ai/catalog/standards/sist/d516b56a-b58b-4312-b66c-620e818731f6/sist-en-12808-4-2002>



EUROPEAN COMMITTEE FOR STANDARDIZATION
COMITÉ EUROPÉEN DE NORMALISATION
EUROPÄISCHES KOMITEE FÜR NORMUNG

Management Centre: rue de Stassart, 36 B-1050 Brussels

Contents

	page
Foreword.....	3
1 Scope	4
2 Normative references	4
3 Sampling	4
4 Test conditions	4
5 Test materials	4
6 Apparatus	4
7 Procedure	5
7.1 Mixing of grouts	5
7.2 Preparation of test specimens.....	5
7.3 Test procedure	5
8 Evaluation of results.....	5
9 Test report	5
Bibliography	9

ITeH STANDARD PREVIEW
(standards.iteh.ai)

[SIST EN 12808-4:2002](https://standards.iteh.ai/catalog/standards/sist/d516b56a-b58b-4312-b66c-620e818731f6/sist-en-12808-4-2002)

<https://standards.iteh.ai/catalog/standards/sist/d516b56a-b58b-4312-b66c-620e818731f6/sist-en-12808-4-2002>

Foreword

This European Standard has been prepared by Technical Committee CEN /TC 67 "Ceramic tiles", the secretariat of which is held by UNI.

This European Standard shall be given the status of a national standard, either by publication of an identical text or by endorsement, at the latest by June 2002, and conflicting national standards shall be withdrawn at the latest by June 2002.

According to the CEN/CENELEC Internal Regulations, the national standards organizations of the following countries are bound to implement this European Standard: Austria, Belgium, Czech Republic, Denmark, Finland, France, Germany, Greece, Iceland, Ireland, Italy, Luxembourg, Netherlands, Norway, Portugal, Spain, Sweden, Switzerland and the United Kingdom.

iTeh STANDARD PREVIEW (standards.iteh.ai)

SIST EN 12808-4:2002

<https://standards.iteh.ai/catalog/standards/sist/d516b56a-b58b-4312-b66c-620e818731f6/sist-en-12808-4-2002>

EN 12808-4:2001 (E)**1 Scope**

This European Standard applies to all ceramic tile grouts for internal and external tile installations on walls and floors.

This standard specifies the test method to be used to determine the shrinkage of ceramic tile grouts.

This European Standard does not contain performance requirements or recommendations for the design and installation of ceramic tiles.

NOTE Ceramic tile grouts can also be used for other types of tiles (natural and agglomerated stones, etc.), where these do not adversely affect the stones.

2 Normative references

This European Standard incorporates by dated or undated reference, provisions from other publications. These normative references are cited at the appropriate places in the text, and the publications are listed hereafter. For dated references subsequent amendments to or revisions of any of these publications apply to this European Standard only when incorporated in it by amendment or revision. For undated references the latest edition of the publication referred to applies (including amendments).

EN 1066, *Adhesives – Sampling*.

EN 1067, *Adhesives - Examination and preparation of samples for testing*.

EN 196-1:1994, *Methods of testing cement - Determination of strength*.

iTeh STANDARD PREVIEW
(standards.iteh.ai)

3 Sampling

Take a sample of at least 2 kg of the product to be tested in accordance with EN 1066 and EN 1067.

[SIST EN 12808-4:2002](https://standards.iteh.ai/catalog/standards/sist/d516b56a-b58b-4312-b66c-620e818731f6/sist-en-12808-4-2002)

<https://standards.iteh.ai/catalog/standards/sist/d516b56a-b58b-4312-b66c-620e818731f6/sist-en-12808-4-2002>

4 Test conditions

Standard conditions shall be (23 ± 2) °C and (50 ± 5) % R.H. and a circulation of air in the working area less than 0,2 m/s.

5 Test materials

Condition all test materials for at least 24 hours under standard conditions.

6 Apparatus

6.1 Three-gang mould used to prepare prismatic specimens 40 mm x 40 mm x 160 mm, with ground surfaces, made of steel, in accordance with EN 196-1:1994. Holes for fitting suitable pins shall be drilled into the ends into the sides of the moulds corresponding to the ends of test specimen (see Figure 1).

6.2 Inserts six smooth, rigid, non-absorbent frames (e.g. in polyethylene or PTFE), with dimensions of 40 mm x 160 mm and thickness of 15 mm.

6.3 Jolting apparatus or jolting table used for the compaction of 10 mm x 40 mm x 160 mm grout specimen; in accordance with 4.6 of EN 196-1:1994.

6.4 Measuring apparatus shall consist of a measurement attachment and a base with adjustment screws. The measurement attachment shall be formed by a dial gauge, which reads accurately to 0,01 mm, rigidly mounted in a measuring frame (see Figures 2, 3, 4).

6.5 Calibration rod or reference rod shall be used as a standard length against which gauge readings can be tested. The rod shall be made of material having a negligible coefficient of expansion (e.g. Invar).

7 Procedure

7.1 Mixing of grouts

The amount of water and/or liquid admix required for preparing the cementitious grout shall be as stated by the manufacturer in parts by weight, i.e. liquid to dry powder.

Prepare at least 2 kg of the grout in a mixer of the type described in 4.4 of EN 196-1:1994, using the slow speed settings, (140 ± 5) rpm rotation and (62 ± 5) rpm planetary movement.

Carry out the following procedure:

- pour the liquid into the pan
- scatter the dry powder over the liquid
- mix for 30 s
- take out the mixing paddle
- scrape down the paddle and pan within 1 min
- replace the paddle and mix for 1 min

Let the grout mature if and as specified in the manufacturer's instructions, and then mix for a further 15 s.

In the case of reaction resin grouts follow the manufacturer's instructions.

7.2 Preparation of test specimens

Insert two non-absorbent frames at the sides of each compartment of the mould, to reduce the width to 10 mm.

Mould the specimens immediately after the preparation of the grout, with the mould firmly clamped to the jolting table.

Introduce, using a suitable scoop, the first of two layers of grout into each of the compartments, directly from the mixing bowl. Spread the layer uniformly, then compact using 60 jolts.

Introduce the second layer of grout, level and compact with a further 60 jolts.

Lift the mould gently from the jolting table, strike off excess of material and smooth the surface with a flat trowel. Wipe off the grout left on the perimeter of the mould. Cover with a glass plate according to EN 196-1:1994.

Place the mould, suitably identified, on a horizontal base in standard conditions, (23 ± 2) °C and (50 ± 5) % R.H.

After 24 hours carefully remove the specimen from the mould and determine with the measuring apparatus (6.4) the length of the test sample (initial reading).

Keep the demoulded prism in standard conditions leaving a clearance of at least 25 mm on all sides.

Prepare three specimens for each grout.

7.3 Test procedure

Take the reading of each specimen 27 days \pm 12 hours after the initial reading.

8 Evaluation of results

The linear shrinkage is evaluated in mm/m as the mean of three values based on the initial measurement.

9 Test report

The test report shall provide the following information:

- a) number, title and issue of this European Standard;
- b) the place and date of sampling;

EN 12808-4:2001 (E)

- c) type of grout, commercial designation and manufacturer name;
- d) identification of the test sample;
- e) handling and storage of samples before testing;
- f) test conditions;
- g) date of testing;
- h) amount of water or liquid used for preparing the grout;
- i) test results (individual and mean values) in mm/m;
- j) any other factor that could have influenced the result.

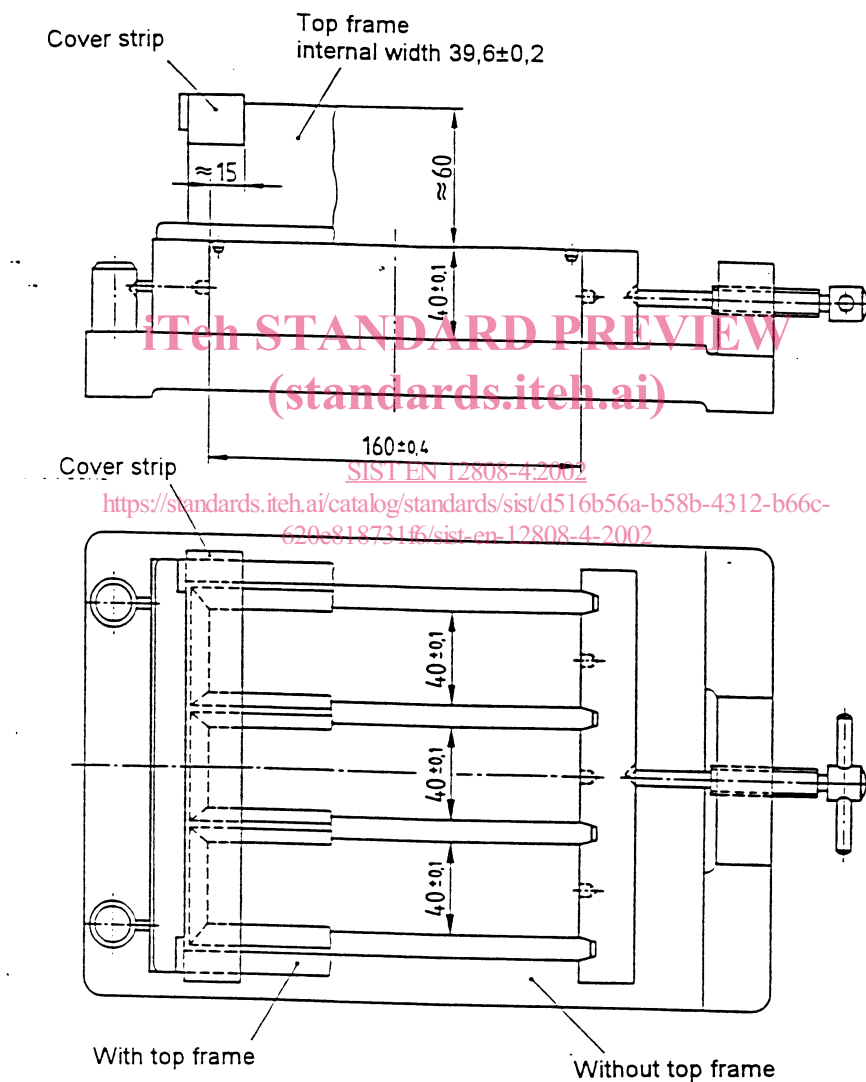
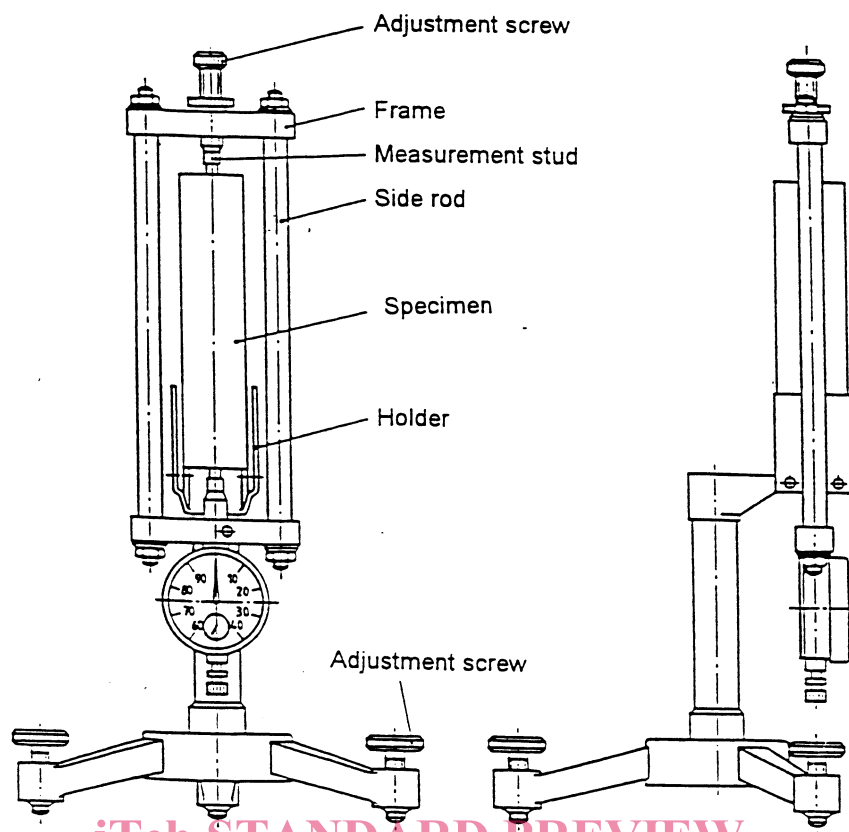

Figure 1 — Three gang mould used to prepare prismatic specimens 40 mm x 40 mm x 160 mm.(All dimensions are in mm)



iTeh STANDARD PREVIEW
(standards.iteh.ai)

Figure 2 — Measuring apparatus (type A)

[SIST EN 12808-4:2002](https://standards.iteh.ai/catalog/standards/sist/d516b56a-b58b-4312-b66c-620e818731f6/sist-en-12808-4-2002)

<https://standards.iteh.ai/catalog/standards/sist/d516b56a-b58b-4312-b66c-620e818731f6/sist-en-12808-4-2002>