

INTERNATIONAL STANDARD

NORME INTERNATIONALE

**Fibre optic interconnecting devices and passive components – Basic test and measurement procedures –
Part 3-3: Examinations and measurements – Active monitoring of changes in attenuation and return loss**

[IEC 61300-3-3:2009](#)

<https://standards.iteh.ai/catalog/standards/sist/1fd0f69d-3407-4035-adc9->

**Dispositifs d'interconnexion et composants passifs à fibres optiques –
Méthodes fondamentales d'essais et de mesures –
Partie 3-3: Examens et mesures – Contrôle actif des variations de
l'affaiblissement et de l'affaiblissement de réflexion**



THIS PUBLICATION IS COPYRIGHT PROTECTED

Copyright © 2009 IEC, Geneva, Switzerland

All rights reserved. Unless otherwise specified, no part of this publication may be reproduced or utilized in any form or by any means, electronic or mechanical, including photocopying and microfilm, without permission in writing from either IEC or IEC's member National Committee in the country of the requester.

If you have any questions about IEC copyright or have an enquiry about obtaining additional rights to this publication, please contact the address below or your local IEC member National Committee for further information.

Droits de reproduction réservés. Sauf indication contraire, aucune partie de cette publication ne peut être reproduite ni utilisée sous quelque forme que ce soit et par aucun procédé, électronique ou mécanique, y compris la photocopie et les microfilms, sans l'accord écrit de la CEI ou du Comité national de la CEI du pays du demandeur.

Si vous avez des questions sur le copyright de la CEI ou si vous désirez obtenir des droits supplémentaires sur cette publication, utilisez les coordonnées ci-après ou contactez le Comité national de la CEI de votre pays de résidence.

IEC Central Office
3, rue de Varembe
CH-1211 Geneva 20
Switzerland

Tel.: +41 22 919 02 11
Fax: +41 22 919 03 00
info@iec.ch
www.iec.ch

About the IEC

The International Electrotechnical Commission (IEC) is the leading global organization that prepares and publishes International Standards for all electrical, electronic and related technologies.

About IEC publications

The technical content of IEC publications is kept under constant review by the IEC. Please make sure that you have the latest edition, a corrigenda or an amendment might have been published.

Useful links:

IEC publications search - www.iec.ch/searchpub

The advanced search enables you to find IEC publications by a variety of criteria (reference number, text, technical committee,...).

It also gives information on projects, replaced and withdrawn publications.

IEC Just Published - webstore.iec.ch/justpublished

Stay up to date on all new IEC publications. Just Published details all new publications released. Available on-line and also once a month by email.

Electropedia - www.electropedia.org

The world's leading online dictionary of electronic and electrical terms containing more than 30 000 terms and definitions in English and French, with equivalent terms in additional languages. Also known as the International Electrotechnical Vocabulary (IEV) on-line.

Customer Service Centre - webstore.iec.ch/csc

If you wish to give us your feedback on this publication or need further assistance, please contact the Customer Service Centre: csc@iec.ch.

A propos de la CEI

La Commission Electrotechnique Internationale (CEI) est la première organisation mondiale qui élabore et publie des Normes internationales pour tout ce qui a trait à l'électricité, à l'électronique et aux technologies apparentées.

A propos des publications CEI

Le contenu technique des publications de la CEI est constamment revu. Veuillez vous assurer que vous possédez l'édition la plus récente, un corrigendum ou amendement peut avoir été publié.

Liens utiles:

Recherche de publications CEI - www.iec.ch/searchpub

La recherche avancée vous permet de trouver des publications CEI en utilisant différents critères (numéro de référence, texte, comité d'études,...).

Elle donne aussi des informations sur les projets et les publications remplacées ou retirées.

Just Published CEI - webstore.iec.ch/justpublished

Restez informé sur les nouvelles publications de la CEI. Just Published détaille les nouvelles publications parues. Disponible en ligne et aussi une fois par mois par email.

Electropedia - www.electropedia.org

Le premier dictionnaire en ligne au monde de termes électroniques et électriques. Il contient plus de 30 000 termes et définitions en anglais et en français, ainsi que les termes équivalents dans les langues additionnelles. Egalement appelé Vocabulaire Electrotechnique International (VEI) en ligne.

Service Clients - webstore.iec.ch/csc

Si vous désirez nous donner des commentaires sur cette publication ou si vous avez des questions contactez-nous: csc@iec.ch.

INTERNATIONAL STANDARD

NORME INTERNATIONALE

**Fibre optic interconnecting devices and passive components – Basic test and measurement procedures –
Part 3-3: Examinations and measurements – Active monitoring of changes in attenuation and return loss**

[IEC 61300-3-3:2009](#)

<https://standards.iteh.ai/catalog/standards/sist/1fd0f69d-3407-4035-adc9->

**Dispositifs d'interconnexion et composants passifs à fibres optiques –
Méthodes fondamentales d'essais et de mesures –
Partie 3-3: Examens et mesures – Contrôle actif des variations de
l'affaiblissement et de l'affaiblissement de réflexion**

INTERNATIONAL
ELECTROTECHNICAL
COMMISSION

COMMISSION
ELECTROTECHNIQUE
INTERNATIONALE

PRICE CODE
CODE PRIX

R

ICS 33.180.20

ISBN 978-2-88912-853-2

**Warning! Make sure that you obtained this publication from an authorized distributor.
Attention! Veuillez vous assurer que vous avez obtenu cette publication via un distributeur agréé.**

CONTENTS

FOREWORD.....	4
1 Scope.....	6
2 Normative references	6
3 General description	6
3.1 Test method	6
3.2 Precautions	7
4 Apparatus.....	7
4.1 Methods 1, 2 and 3.....	7
4.1.1 General	7
4.1.2 Source (S).....	7
4.1.3 Launch condition (E).....	8
4.1.4 Monitoring equipment	8
4.1.5 Detector D	9
4.1.6 Stress fixture	9
4.1.7 Branching device BD	9
4.1.8 Temporary joints.....	9
4.1.9 Data acquisition.....	9
4.1.10 Monitor sample	9
4.1.11 Reference fibre.....	9
4.2 Methods 4 and 5.....	11
4.2.1 General	11
4.2.2 OTDR	11
4.2.3 Buffer fibre	11
4.2.4 Optical switches	11
5 Procedure	13
5.1 Monitoring attenuation and return loss of a single sample – method 1	13
5.1.1 General	13
5.1.2 Attenuation monitoring – method 1	13
5.1.3 Return loss monitoring – method 1	14
5.2 Monitoring attenuation and return loss of multiple samples using a 1 × N branching device – method 2.....	14
5.2.1 General	14
5.2.2 Attenuation monitoring – method 2	14
5.2.3 Return loss monitoring – method 2	14
5.3 Monitoring attenuation and return loss of multiple samples using two 1 × N optical switches – method 3	14
5.3.1 General	14
5.3.2 Attenuation – method 3.....	14
5.3.3 Return loss – method 3.....	15
5.4 Bidirectional OTDR monitoring of attenuation and return loss of multiple samples – method 4	16
5.4.1 General	16
5.4.2 Attenuation – method 4.....	16
5.4.3 Return loss – method 4.....	18
5.5 Unidirectional OTDR monitoring of attenuation and return loss of multiple samples – method 5	19
6 Details to be specified	19

6.1	Method 1	19
6.2	Methods 2 and 3.....	20
6.3	Methods 4 and 5.....	20
Figure 1	– Method 1 – Monitoring attenuation and return loss of a single sample undergoing stress testing.....	10
Figure 2	– Method 2 – Monitoring attenuation and return loss of multiple samples using a 1 × N branching device	10
Figure 3	– Method 3 – Monitoring attenuation and return loss of multiple samples using two 1 × N optical switches	11
Figure 4	– Method 4 – Bidirectional OTDR monitoring of attenuation and return loss of multiple samples.....	12
Figure 5	– Method 5 – Unidirectional OTDR monitoring of attenuation and return loss of multiple samples	13
Figure 6	– Cut-back measurement location (transmission)	15
Figure 7	– Typical OTDR trace caused by the reflection from a DUT	17
Figure 8	– Cut-back measurement location (OTDR)	18
Table 1	– Example values for Rayleigh backscatter coefficient.....	19

iTeh STANDARD PREVIEW
(standards.iteh.ai)

[IEC 61300-3-3:2009](#)

<https://standards.iteh.ai/catalog/standards/sist/1fd0f69d-3407-4035-adc9-eb1fd604ace/iec-61300-3-3-2009>

INTERNATIONAL ELECTROTECHNICAL COMMISSION

**FIBRE OPTIC INTERCONNECTING DEVICES
AND PASSIVE COMPONENTS –
BASIC TEST AND MEASUREMENT PROCEDURES –****Part 3-3: Examinations and measurements –
Active monitoring of changes in attenuation and return loss**

FOREWORD

- 1) The International Electrotechnical Commission (IEC) is a worldwide organization for standardization comprising all national electrotechnical committees (IEC National Committees). The object of IEC is to promote international co-operation on all questions concerning standardization in the electrical and electronic fields. To this end and in addition to other activities, IEC publishes International Standards, Technical Specifications, Technical Reports, Publicly Available Specifications (PAS) and Guides (hereafter referred to as "IEC Publication(s)"). Their preparation is entrusted to technical committees; any IEC National Committee interested in the subject dealt with may participate in this preparatory work. International, governmental and non-governmental organizations liaising with the IEC also participate in this preparation. IEC collaborates closely with the International Organization for Standardization (ISO) in accordance with conditions determined by agreement between the two organizations.
- 2) The formal decisions or agreements of IEC on technical matters express, as nearly as possible, an international consensus of opinion on the relevant subjects since each technical committee has representation from all interested IEC National Committees.
- 3) IEC Publications have the form of recommendations for international use and are accepted by IEC National Committees in that sense. While all reasonable efforts are made to ensure that the technical content of IEC Publications is accurate, IEC cannot be held responsible for the way in which they are used or for any misinterpretation by any end user.
- 4) In order to promote international uniformity, IEC National Committees undertake to apply IEC Publications transparently to the maximum extent possible in their national and regional publications. Any divergence between any IEC Publication and the corresponding national or regional publication shall be clearly indicated in the latter.
- 5) IEC provides no marking procedure to indicate its approval and cannot be rendered responsible for any equipment declared to be in conformity with an IEC Publication.
- 6) All users should ensure that they have the latest edition of this publication.
- 7) No liability shall attach to IEC or its directors, employees, servants or agents including individual experts and members of its technical committees and IEC National Committees for any personal injury, property damage or other damage of any nature whatsoever, whether direct or indirect, or for costs (including legal fees) and expenses arising out of the publication, use of, or reliance upon, this IEC Publication or any other IEC Publications.
- 8) Attention is drawn to the Normative references cited in this publication. Use of the referenced publications is indispensable for the correct application of this publication.
- 9) Attention is drawn to the possibility that some of the elements of this IEC Publication may be the subject of patent rights. IEC shall not be held responsible for identifying any or all such patent rights.

International Standard IEC 61300-3 has been prepared by subcommittee 86B: Fibre optic interconnecting devices and passive components, of IEC technical committee 86: Fibre optics.

This third edition cancels and replaces the second edition published in 2003. This edition constitutes a minor revision.

The change with respect to the previous edition is the structure of the document.

This bilingual version (2012-01) corresponds to the monolingual English version, published in 2009-03.

The text of this standard is based on the following documents:

FDIS	Report on voting
86B/2808/FDIS	86B/2830/RVD

Full information on the voting for the approval of this standard can be found in the report on voting indicated in the above table.

The French version of this standard has not been voted upon.

This publication has been drafted in accordance with the ISO/IEC Directives, Part 2.

A list of all parts of IEC 61300 series, published under the general title *Fibre optic interconnecting devices and passive components – Basic test and measurement procedures*, can be found on the IEC website.

The committee has decided that the contents of this publication will remain unchanged until the maintenance result date indicated on the IEC web site under "<http://webstore.iec.ch>" in the data related to the specific publication. At this date, the publication will be

- reconfirmed,
- withdrawn,
- replaced by a revised edition, or [IEC 61300-3-3:2009](http://standards.iteh.ai/catalog/standards/sist/1fd0f69d-3407-4035-adc9-eb1fdd604ace/iec-61300-3-3-2009)
- amended. <https://standards.iteh.ai/catalog/standards/sist/1fd0f69d-3407-4035-adc9-eb1fdd604ace/iec-61300-3-3-2009>

ITeH STANDARD PREVIEW
(standards.iteh.ai)

FIBRE OPTIC INTERCONNECTING DEVICES AND PASSIVE COMPONENTS – BASIC TEST AND MEASUREMENT PROCEDURES –

Part 3-3: Examinations and measurements – Active monitoring of changes in attenuation and return loss

1 Scope

This part of IEC 61300 describes the procedure to monitor changes in attenuation and/or return loss of a component or an interconnecting device, when subjected to an environmental or mechanical test. Such a procedure is commonly referred to as active monitoring. In many instances, it is more efficient to monitor attenuation and return loss at the same time.

The procedure may be applied to measurements on single samples or to simultaneous measurements on multiple samples, both at single wavelengths and multiple wavelengths, by using branching devices and/or switches as appropriate.

2 Normative references

The following referenced documents are indispensable for the application of this document. For dated references, only the edition cited applies. For undated references, the latest edition of the referenced document (including any amendments) applies.

[IEC 61300-3-3:2009](#)

IEC 61300-1, *Fibre optic interconnecting devices and passive components – Basic test and measurement procedures – Part 1: General and guidance*

IEC 61300-3-1, *Fibre optic interconnecting devices and passive components – Basic test and measurement procedures – Part 3-1: Examinations and measurements – Visual examination*

IEC 61300-3-6, *Fibre optic interconnecting devices and passive components – Basic test and measurement procedures – Part 3-6: Examinations and measurements – Return loss*

IEC 61300-3-35, *Fibre optic interconnecting devices and passive components – Basic test and measurement procedures – Part 3-35: Examinations and measurements – Fibre optic connector endface visual and automated inspection*

3 General description

3.1 Test method

The procedure describes a number of active monitoring measurement methods. Method 1 describes the situation where a single sample is subject to mechanical or environmental stress testing. Methods 2 and 3 describe methods for monitoring changes in the optical performance of multiple samples. Methods 4 and 5 measure changes in the optical performance of samples using an OTDR. Methods 4 and 5 may be used only when the OTDR averaging time is much less than the variation time of the test conditions. Where there is any form of uncertainty over the measurement method used, method 1 shall be considered to be the reference method.

All methods are capable of being configured to monitor changes in attenuation and return loss at the same time. The required optical test parameters shall be defined in the relevant specification.

Where a group of samples is being monitored over a period of time, say several days or weeks, it is usual to employ some form of automated data acquisition. Also, since the changes in optical performance can be very small, it is important to ensure high measurement stability over time.

3.2 Precautions

The following requirements shall be met.

- a) Precautions shall be taken to ensure that cladding modes do not affect the measurement.
- b) Precautions shall be taken to prevent movement in the position of the fibre cables between the sample(s) and the test apparatus, to avoid changes in optical performance caused by bending losses.
- c) The stability performance of the test equipment shall be $\leq 0,05$ dB or 10 % of the attenuation to be measured, whichever is the lower value. The stability shall be maintained over the measurement time. The required measurement resolution shall be 0,01 dB for both multimode and single-mode.
- d) To achieve consistent results, clean and inspect all samples prior to measurement in accordance with the manufacturer's instructions. Visual examination shall be undertaken in accordance with IEC 61300-3-1 and IEC 61300-3-35.
- e) The power in the fibre shall be at a level that does not generate non-linear scattering effects (typically < 3 mW).
- f) It is common to be monitoring changes in optical performance that are small in comparison with the polarization dependence of the components under test (DUT) and of parts of the test apparatus such as branching devices, switches and detectors. Therefore, it is usually necessary to specify light sources with a low degree of polarization or to couple the source to low polarization-inducing optics.
- g) Particularly, when measuring wavelength dependent components such as multiplexers or attenuators, it is necessary to use a light source that does not emit light at extraneous wavelengths at levels that can affect the measurement accuracy.
- h) Reflected powers from the test apparatus shall be at a level that does not affect the measurement accuracy.
- i) Care must be taken when using switches or branching devices for multimode measurements. In many cases, these devices will modify the launched mode power distribution or result in modal detection non-uniformity, which will give rise to measurement inaccuracies.

4 Apparatus

4.1 Methods 1, 2 and 3

4.1.1 General

The apparatus used for methods 1, 2 and 3 of this procedure is shown in Figures 1, 2 and 3. The apparatus consists of the following.

4.1.2 Source (S)

The source consists of an optical emitter, the means to connect to it, and associated drive electronics. In addition to meeting the stability and power level requirements, the source shall have the following characteristics.

Centre wavelength:	as detailed in the performance and product standard
Spectral width:	filtered LED ≤ 150 nm full width at half maximum (FWHM)
Spectral width:	LD < 10 nm FWHM

For multimode fibres, broadband sources such as an LED shall be used.

NOTE 1 The interference of modes from a coherent source will create speckle patterns in multimode fibre. These speckle patterns give rise to speckle or modal noise and are observed as power fluctuations, since their characteristic times are longer than the resolution time of the detector. As a result, it may be impossible to achieve stable launch conditions using coherent sources for multimode measurements. Consequently, lasers should be avoided in favour of LEDs or other incoherent sources for measuring multimode components.

For single-mode fibres, either an LED or an LD may be used.

There are a number of methods of monitoring performance at multiple wavelengths. One method, illustrated in Figure 3, shows independent light sources joined by an optical switch SW3.

NOTE 2 It is particularly important to consider the wavelength dependence of the test apparatus when monitoring multiple wavelengths. For example, different switch ports may not have the same wavelength dependence. This can affect comparative measurements made between any channel “i” and the reference channel, since they will be connected to different switch ports. It is therefore necessary, in such circumstances, to complete an accurate spectral characterization of the test set-up prior to use.

4.1.3 Launch condition (E)

The launch condition shall be specified in accordance with Annex B of IEC 61300-1.

4.1.4 Monitoring equipment

Where multiple measurements are made, suitable apparatus is required to permit monitoring of the light through the multiple paths.

In Figure 2, individual monitoring channels are established by dividing the light into N paths using a $1 \times N$ branching device (BD). This method is practical for a small number of DUTs, since it requires a multiplicity of branching devices and detectors.

In Figure 3, active switching of the light paths through the DUTs is used. The apparatus consists of a directional branching device and two $1 \times N$ computer-controlled optical switches. The channel number of these switches is sufficiently large to accommodate the DUTs under test, one or more reference lines, and a reference reflectance channel.

NOTE The design of systems to test multiple samples requires the trade-off of a number of factors such as cost and measurement capability. When testing multimode samples, for example, it may be inappropriate to use branching devices and/or optical switches, due to the problems surrounding modal losses and the associated cost of the test apparatus. However, optical switches may be cost-effective for testing single-mode samples, particularly when the cost of suitable sources and detectors and the measurement stability requirements are considered.

Switch parameters which shall be considered for this test include the following.

a) Repeatability

The switches shall be capable of high repeatability in per-channel insertion loss, since this parameter will directly detract from the accuracy of the measurement of attenuation or return loss of the DUT. Furthermore, since environmental tests are generally carried out over extended periods the switch repeatability shall be considered over the full duration of the test.

b) Return loss

The return loss characteristics of the switch shall be such that they do not unduly influence the measurement in methods 2 and 3.

c) Wavelength dependence

When undertaking multiple wavelength measurements, the wavelength dependence characteristics of the switch shall be taken into account, to ensure they do not unduly influence the measurement in methods 2 and 3.

4.1.5 Detector (D)

The detector consists of an optical detector, the means to connect to it, and associated electronics. The connection to the detector will be an adaptor that accepts a connector plug of the appropriate design. The detector shall capture all light emitted by the connector plug.

In addition to meeting the stability and resolution requirements, the detector shall have the following characteristics.

Linearity: Multimode $\pm 0,25$ dB (over -5 dBm to -60 dBm)
Single-mode $\pm 0,1$ dB (over -5 dBm to -60 dBm)

NOTE The power meter linearity should be referenced to a power level of -23 dBm at the operational wavelength.

The detectors shall have a high dynamic range with an operational wavelength range consistent with that of the DUT and the capability to zero the reference level.

4.1.6 Stress fixture

The stress fixture consists of a suitable mechanism for applying the required stress level(s) to the DUTs. In the case of environmental stress testing, the fixture will typically consist of an environmental chamber capable of meeting the required temperature and/or humidity extremes. In the case of mechanical stress testing, a number of different fixtures will often be required depending on the requirements of the relevant specification, for example, impact rigs, tensile testers, vibration beds, etc.

4.1.7 Branching device (BD)

The splitting ratio of the BD shall be stable. It shall also be insensitive to polarization. The directivity should be at least 10 dB higher than the maximum return loss to be measured.

4.1.8 Temporary joints

Temporary joints are typically used for connecting the DUTs to the test apparatus. Generally, the stability requirements of a test will require that the temporary joints be mechanical or fusion splices.

4.1.9 Data acquisition

Data recording may be done either manually or automatically. Measurements shall be made at intervals as defined in the relevant specification. Appropriate data acquisition apparatus shall be used where measurements are performed automatically.

4.1.10 Monitor sample

A monitor sample provides a direct performance comparison with the sample(s) under test and shall be used for environmental testing of samples. The monitor sample is similar to those under test, except that it does not contain a DUT. For example, where the DUT is a connector, the monitor sample is simply a length of fibre cable of the same type, located in the same environment as the DUT. The monitor sample shall be placed as close as possible to the DUT(s).

4.1.11 Reference fibre

A reference fibre is typically employed for the purpose of monitoring and compensating for source instability. Reference fibres shall be used where there is no monitor sample and the source does not have sufficient stability to give the required measurement accuracy.

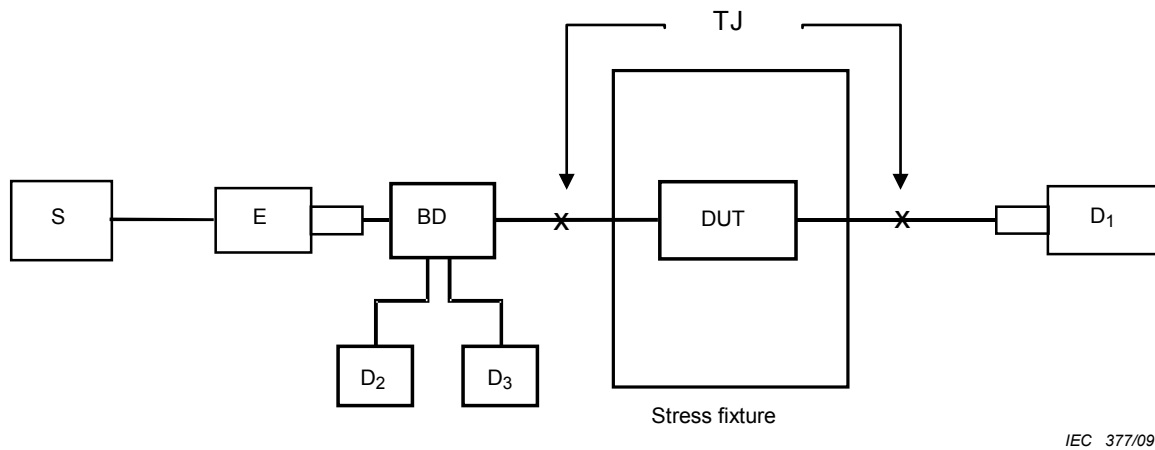

Figure 1 – Method 1 – Monitoring attenuation and return loss of a single sample undergoing stress testing

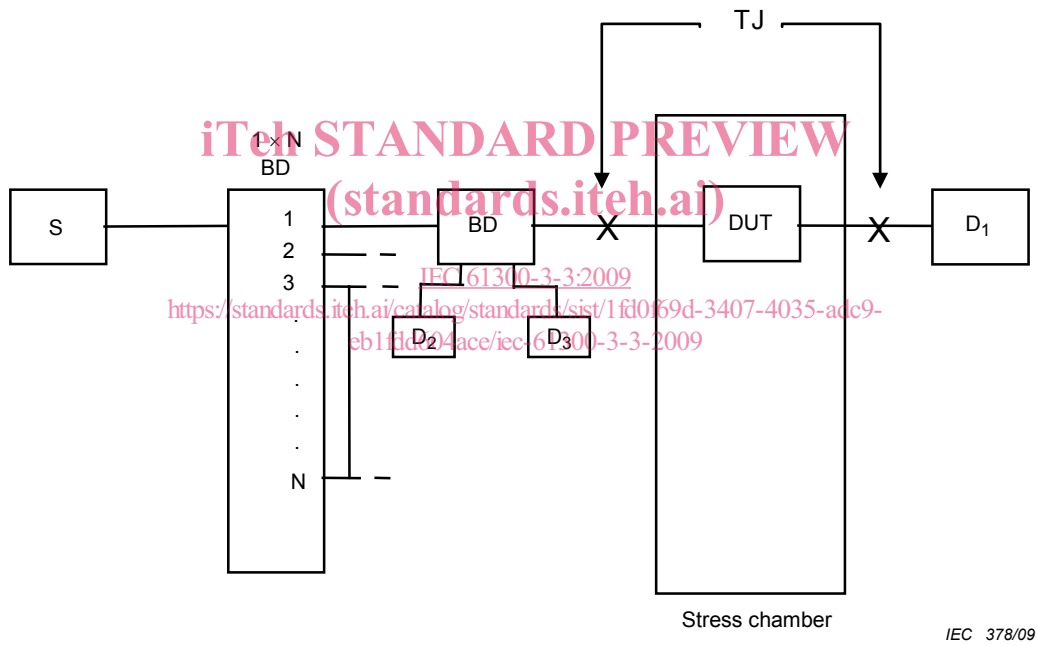
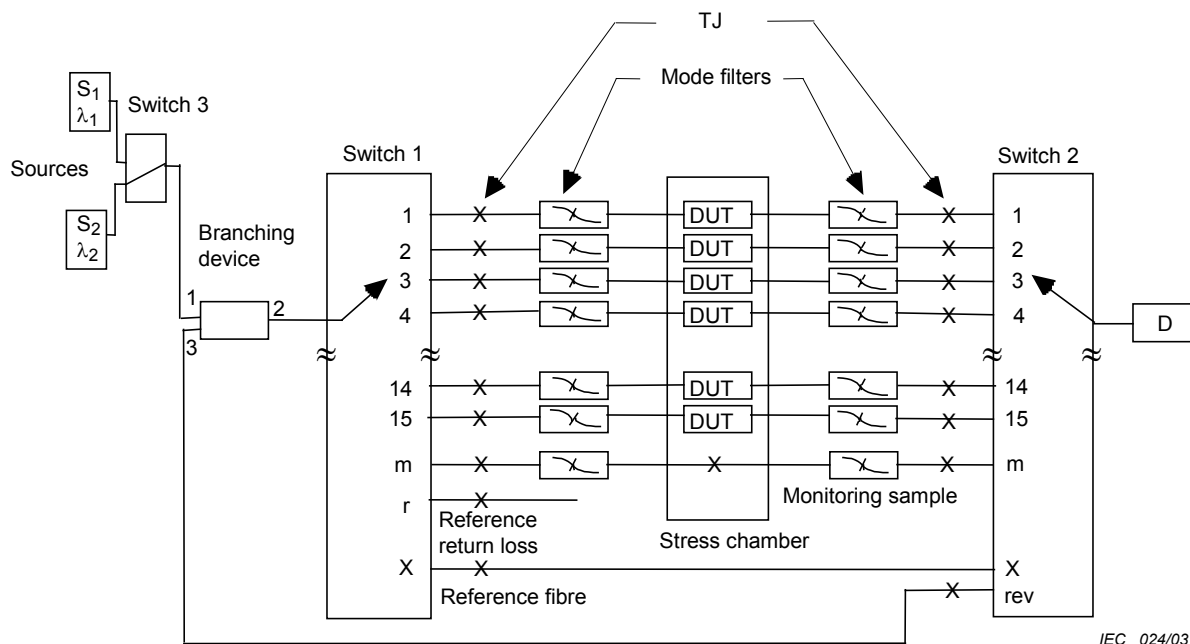

Figure 2 – Method 2 – Monitoring attenuation and return loss of multiple samples using a 1 x N branching device



IEC 024/03

Figure 3 – Method 3 – Monitoring attenuation and return loss of multiple samples using two 1 × N optical switches

STANDARD PREVIEW
(standards.iteh.ai)

4.2 Methods 4 and 5

4.2.1 General

The apparatus for these methods and its arrangement to monitor multiple DUTs is shown in Figures 4 and 5. Additional or alternative apparatus required to conduct these tests consists of the following elements.

4.2.2 OTDR

In these methods, an OTDR is employed as an automated test set. The OTDR shall be capable of producing one or more pulse durations and pulse repetition rates. The precise characteristics shall be compatible with the measurement requirements and shall be specified in the relevant specification.

NOTE The long averaging times required for return-loss measurements may limit the minimum time period for sequential measurements.

4.2.3 Buffer fibre

Lengths of fibre are used to permit spatial discrimination of the DUT(s) by the OTDR.

4.2.4 Optical switches

The key differences from those switches described in methods 2 and 3 are as follows.

a) Repeatability

There is less need in methods 4 and 5 for extremely high levels of long-term repeatability of per-channel attenuation, since the OTDR is able to distinguish the switches from the DUT(s).

b) Return loss

In methods 3 and 4 very high values of switch return loss are required, since these reflections can, depending on the particular OTDR, obscure the measurement.