



Designation: C 140 – 01a^{ε1}

Standard Test Methods for Sampling and Testing Concrete Masonry Units and Related Units¹

This standard is issued under the fixed designation C 140; the number immediately following the designation indicates the year of original adoption or, in the case of revision, the year of last revision. A number in parentheses indicates the year of last reapproval. A superscript epsilon (ε) indicates an editorial change since the last revision or reapproval.

This standard has been approved for use by agencies of the Department of Defense.

^{ε1} NOTE—Equation 4 was corrected editorially in July 2001.

1. Scope *

1.1 These test methods cover the sampling and testing of concrete masonry units for dimensions, compressive strength, absorption, unit weight (density), and moisture content. Flexural load testing and ballast weight determination of concrete roof pavers are also covered.

NOTE 1—The testing laboratory performing these test methods should be evaluated in accordance with Practice C 1093.

1.2 The values stated in inch-pound units are to be regarded as the standard. The values given in parentheses are for information only.

1.3 *This standard does not purport to address all of the safety concerns, if any, associated with its use. It is the responsibility of the user of this standard to establish appropriate safety and health practices and determine the applicability of regulatory limitations prior to use.*

2. Referenced Documents

2.1 ASTM Standards:

- C 90 Specification for Loadbearing Concrete Masonry Units²
- C 143 Test Method for Slump of Hydraulic-Cement Concrete³
- C 1093 Practice for Accreditation of Testing Agencies for Unit Masonry²
- C 1209 Terminology of Concrete Masonry Units and Related Units²
- C 1232 Terminology of Masonry²
- E 4 Practices for Force Verification of Testing Machines⁴
- E 6 Terminology Relating to Methods of Mechanical Testing⁴

¹ These test methods are under the jurisdiction of ASTM Committee C15 on Manufactured Masonry Units and are the direct responsibility of Subcommittee C15.03 on Concrete Masonry Units and Related Units.

Current edition approved June 10, 2001. Published August 2001. Originally published as C 140–38T. Last previous edition C 140–00.

² *Annual Book of ASTM Standards*, Vol 04.05.

³ *Annual Book of ASTM Standards*, Vol 04.02.

⁴ *Annual Book of ASTM Standards*, Vol 03.01.

3. Terminology

3.1 Terminology defined in Terminology C 1209, Terminology C 1232, and Terminology E 6 shall apply for these test methods.

4. Sampling

4.1 Selection of Test Specimens:

4.1.1 For purposes of test, full-size concrete masonry units shall be selected by the purchaser or authorized representative. The selected specimens shall be of similar configuration and dimensions. Specimens shall be representative of the whole lot of units from which they are selected. If test specimens are selected at the work site, units for moisture content tests shall be sampled upon delivery to the purchaser and placed in a sealed container until the received weight (W_r) is determined in accordance with 4.3.2.

4.1.2 The term “lot” refers to any number of concrete masonry units of any configuration or dimension manufactured by the producer using the same materials, concrete mix design, manufacturing process, and curing method.

4.2 Number of Specimens:

4.2.1 For the compressive strength, absorption, unit weight (density), and moisture content determinations, six units shall be selected from each lot of 10 000 units or fraction thereof and 12 units from each lot of more than 10 000 and less than 100 000 units. For lots of more than 100 000 units, six units shall be selected from each 50 000 units or fraction thereof contained in the lot. Additional specimens may be taken at the discretion of the purchaser.

4.3 Identification:

4.3.1 Mark each specimen so that it may be identified at any time. Markings shall cover not more than 5 % of the superficial area of the specimen.

4.3.2 Weigh units for moisture content tests immediately after sampling and marking and record as W_r (received weight).

5. Measurement of Dimensions

5.1 Apparatus:

5.1.1 Measure overall dimensions with a steel scale having divisions not greater than 1/10-in. (2.5-mm). Face shell and web

*A Summary of Changes section appears at the end of this standard.

thicknesses shall be measured with a caliper rule having divisions not greater than 1/100-in. (0.25-mm) and having parallel jaws not less than 1/2 in. (12.7 mm) nor more than 1 in. (25.4 mm) in length.

5.2 *Specimens*—Three full-size units shall be measured for width, height, and length, and minimum thicknesses of face shells and webs.

NOTE 2—The same specimens may be used in other tests.

5.3 *Measurements:*

5.3.1 For each unit, measure and record the width (*W*) across the top and bottom bearing surfaces at mid-length, height (*H*) at mid-length of each face, and length (*L*) at mid-height of each face.

5.3.2 For each unit, measure face shell thicknesses (*t_f*) and web thicknesses (*t_w*) at the thinnest point of each such element 1/2 in. (12.7 mm) down from the top surface of the unit as manufactured (typically the bottom surface of the unit as laid) and record to the nearest division of the scale or caliper. Where the thinnest point of opposite face shells differ in thickness by less than 1/8 in. (3.2 mm), average their measurements to determine the minimum face shell thickness for that unit. Average the measurements of all of the webs in each unit to determine the minimum web thickness for that unit. Exclude webs having a thickness less than 0.75 in. (19.1 mm) when determining minimum web thickness. Disregard sash grooves, dummy joints, and similar details in the measurements.

6. **Compressive Strength**

6.1 *Test Apparatus*—The testing machine shall have an accuracy of ±1.0 % over the anticipated load range. The upper platen shall be a spherically seated, hardened metal block firmly attached at the center of the upper head of the machine. The center of the sphere shall lie at the center of the surface held in its spherical seat but shall be free to turn in any direction, and its perimeter shall have at least 1/4 in. (6.3 mm) clearance from the head to accommodate specimens whose bearing surfaces are not parallel. The diameter of the upper platen (determined in accordance with A1.3) shall be at least 6 in. (150 mm). A hardened metal bearing plate may be used beneath the specimen to minimize wear of the lower platen of the machine.

6.1.1 When the bearing area of the upper platen or lower platen is not sufficient to cover the area of the specimen, a single steel bearing plate with a thickness equal to at least the distance from the edge of the platen to the most distant corner of the specimen shall be placed between the platen and the capped specimen. The length and width of the steel plate shall be at least 1/4 in. (6.3 mm) greater than the length and width of the units.

6.1.2 The surfaces of the platen or plate intended for contact with the specimen shall have a hardness not less than HRC 60 (BHN 620). The surfaces of the platen and plate shall not depart from plane surfaces by more than 0.001 in. (0.03 mm) in any 6-in. (150-mm) dimension.

NOTE 3—Research has shown that thickness of bearing plates has a significant effect on the tested compressive strength of masonry units when the bearing area of the platen is not sufficient to cover the area of the specimen. Plate bending results in nonuniform stress distributions that can

influence the failure mechanisms of the tested specimens. The magnitude of this effect is controlled by the stiffness of the plate, the size of the specimen tested, and the strength of the specimen. Tested compressive strengths will typically increase with increased plate thickness and with reduced distance to the furthest corner of the specimen. Some testing laboratories have limitations that limit the practicality of eliminating plate bending entirely. Therefore the plate thickness requirements in 6.1 are intended to provide an adequate level of accuracy in the compression test results so as to conform to the limits of practicality of the testing laboratory.

NOTE 4—Annex A1 includes guidance on determining the required plate thicknesses based on the configurations of the test specimen and the test machine.

6.2 *Test Specimens:*

6.2.1 Of the six units sampled, three shall be tested in compression. After delivery to the laboratory, store (unstacked and separated by not less than 0.5 in. (13 mm) on all sides) continuously in air at a temperature of 75 ± 15°F (24 ± 8°C) and a relative humidity of less than 80 % for not less than 48 h. Alternatively, if compression results are required sooner, store units unstacked in the same environment described above with a current of air from an electric fan passing over them for a period of not less than 4 h. Continued until two successive weighings at intervals of 2 h show an increment of loss of not greater than 0.2 % of the previous determined weight of the specimen and until no moisture or dampness is visible on any surface of the unit. Specimens shall not be subjected to oven-drying. Specimens shall be full sized units except as modified in 6.2.2 through 6.2.5.

NOTE 5—In this test method, net area (other than certain solid units, see 9.4) is determined from specimens other than those subjected to compression testing. The compressive strength method is based on the assumption that units used for determining net volume (absorption specimens) have the same net volume as units used for compression testing. Sampled split face units, which have irregular surfaces, should be divided at the time they are sampled from the lot, such that the absorption test specimens have a net volume that is visually representative and a weight that is representative of the compression test specimens.

6.2.2 Unsupported projections having a length greater than the thickness of the projection shall be removed by saw-cutting. For units with recessed webs, the face shell projecting above the web shall be removed by saw-cutting to provide a full bearing surface over the net cross section of the unit.

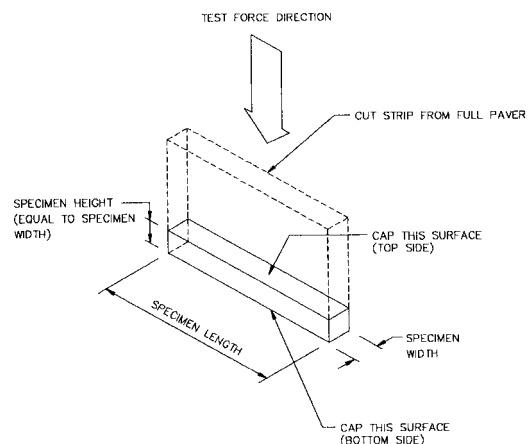

FIG. 1 Compressive Strength Test Setup for Concrete Roof Pavers

Where the resulting unit height would be reduced by more than one-third of the original unit height, the unit shall be coupon tested in accordance with 6.2.4.

6.2.3 When compression testing full-sized units that are too large for the test machine's bearing block and platens or are beyond the load capacity of the test machine, saw-cut the units to properly size them to conform to the capabilities of the testing machine. The resulting specimen shall have no face shell projections or irregular webs and shall be a fully enclosed cell or cells. The compressive strength of the segment shall be considered to be the compressive strength of the whole unit.

6.2.4 When compression testing units of unusual size and shape (see Note 6), the specimens shall be sawed to remove any face shell projections. The resulting specimen shall be a cell or cells containing four sides that will ensure a 100 % bearing surface. Where saw-cutting will not result in an enclosed four-sided unit, the specimen shall be a coupon cut from a face shell of each unit. The coupon size shall have a height to thickness ratio of 2 to 1 before capping and a length to thickness ratio of 4 to 1. The thickness of the coupon shall be as large as possible based on the configuration of the unit and the capacities of the testing machine and shall not be less than 1.25 in. (30 mm). The coupon shall be cut from the unit such that the coupon height dimension is in the same direction as the unit height dimension. The compressive strength of the coupon shall be the net area compressive strength of the whole unit.

NOTE 6—Examples of units having unusual size or shape include, but are not limited to, bond beam units, open end units, and pilaster units.

6.2.5 For concrete roof paver compressive strength tests, cut three test specimens from three whole paver units. Each specimen shall consist of a strip of paver with specimen height equal to specimen width. Where a unit contains supporting ribs, obtain specimens by cutting perpendicular to the direction of the ribs so as to avoid inclusion of bevelled or recessed surfaces at top or bottom edges (see Fig. 1).

6.2.6 For segmental retaining wall unit compressive strength tests, tested specimens shall be a coupon with a height to thickness ratio of 2 to 1 before capping and length to thickness ratio of 4 to 1. Saw-cutting, if necessary to obtain the required test specimen, shall be performed in accordance with 6.2.6.1 and 6.2.7.

6.2.6.1 The coupon width shall be as close to 2 in. as possible, but in no case less than 1.5 in. (37 mm). Coupon dimensions shall not differ by more than 1/8 in. (3 mm) from the targeted dimension. The compressive strength of the coupon shall be considered to be the compressive strength of the whole unit.

NOTE 7—The compressive strength of coupons saw-cut from segmental retaining wall units can be measurably influenced by the unit configuration, location of sample, and size of sample. Therefore, for the purposes of comparing compressive strength results between independently performed tests, suppliers should be consulted for the recommended coupon sample location and size.

6.2.7 Sawing shall be performed in an accurate, competent manner subjecting the specimen to as little saw vibration as possible. Use a diamond saw blade of proper hardness. If the specimen is wetted during sawing, allow the specimen to dry to

equilibrium with laboratory air conditions before testing using the procedures outlined in 6.2.1.

6.2.8 If compression test specimens have been saw-cut from full-size units in accordance with the provisions of 6.2.2 through 6.2.5 and the net area of the compression test specimens can not be determined by 9.4.1, saw-cut an additional three units to the dimensions and configuration of the three compression test specimens. The average net area for the saw-cut compression specimens shall be taken as the average net area of the additional three saw-cut units calculated as required in 9.4. Calculated net volumes of saw-cut specimens shall not be used in calculating equivalent thickness.

6.3 *Capping Test Specimens:*

6.3.1 Cap bearing surfaces of units by one of the methods in 6.3.2 or 6.3.3.

6.3.2 *Sulfur and Granular Materials*—Spread evenly on a nonabsorbent capping surface that has been lightly coated with oil (Note 8) or sprayed with a TFE-fluorocarbon coating. Use proprietary or laboratory prepared mixtures of 40 to 60 % sulfur by weight, the remainder being ground fire clay or other suitable inert material passing a No. 100 (150- μ m) sieve with or without a plasticizer. Heat the sulfur mixture in a thermostatically controlled heating pot to a temperature sufficient to maintain fluidity after contact with the capping surface. Take care to prevent overheating, and stir the liquid in the pot just before use. The capping surface shall be plane within 0.003 in. (0.08 mm) in 16 in. (406.4 mm) and shall be sufficiently rigid and supported so as not to be measurably deflected during the capping operation. Place four 1-in. (25-mm) square steel bars on the capping surface plate to form a rectangular mold approximately 1/2 in. (12.7 mm) greater in either inside dimension than the masonry unit. Fill the mold to a depth of 1/4 in. (6.4 mm) with molten sulfur material. Bring the surface of the unit to be capped quickly into contact with the liquid, and insert the specimen, holding it so that its axis is at right angles to the surface of the capping liquid. Allow the unit to remain undisturbed until solidification is complete. Allow the caps to cool for a minimum of 2 h before testing the specimens. Patching of caps shall not be permitted. Remove imperfect caps and replace with new ones.

NOTE 8—The use of oil on capping plates may be omitted if it is found that plate and unit can be separated without damaging the cap.

6.3.3 *Gypsum Cement Capping*—Spread evenly on a nonabsorbent capping surface that has been lightly coated with oil (Note 8) or sprayed with a TFE-fluorocarbon coating, a neat paste of special high-strength gypsum cement (Note 9) and

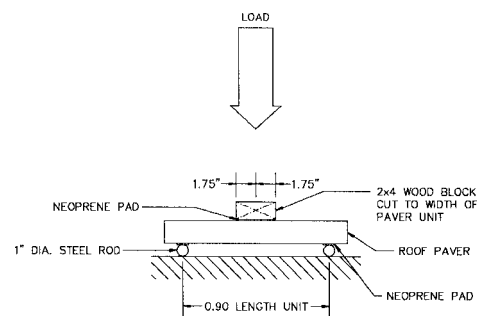

FIG. 2 Flexural Strength Test Setup for Concrete Roof Pavers

water. Such gypsum cement, when gaged with water at the capping consistency, shall have a compressive strength at a 2-h age of not less than 3500 psi (24.1 MPa) when tested as 2-in. (50.8-mm) cubes. The casting surface plate shall conform to the requirements described in 6.3.2. Bring the surface of the unit to be capped into contact with the capping paste; firmly press down the specimen with a single motion, holding it so that its axis is at right angles to the capping surface. The average thickness of the cap shall not exceed 1/8 in. (3.2 mm). Patching of caps shall not be permitted. Remove imperfect caps and replace with new ones. Age the caps for at least 2 h before testing the specimens.

NOTE 9—The following two gypsum cements are considered to be in this classification: Hydrostone and Hydrocal white gypsum cement. Other cements should not be used unless shown by test to meet the strength requirement.

6.4 Procedure:

6.4.1 Position of Specimens—Test specimens with the centroid of their bearing surfaces aligned vertically with the center of thrust of the spherically seated steel bearing block of the testing machine (Note 10). Except for special units intended for use with their cores in a horizontal direction, test all hollow concrete masonry units with their cores in a vertical direction. Test masonry units that are 100 % solid and special hollow units intended for use with their hollow cores in a horizontal direction in the same direction as in service.

NOTE 10—For those masonry units that are symmetrical about an axis, the location of that axis can be determined geometrically by dividing the dimension perpendicular to that axis (but in the same plane) by two. For those masonry units that are nonsymmetrical about an axis, the location of that axis can be determined by balancing the masonry unit on a knife edge or a metal rod placed parallel to that axis. If a metal rod is used, the rod shall be straight, cylindrical (able to roll freely on a flat surface), have a diameter of not less than 1/4 in. (6.4 mm) and not more than 3/4 in. (19.1 mm), and its length shall be sufficient to extend past each end of the specimen when placed upon it. The metal rod shall be placed on a smooth, flat, level surface. One determined, the centroidal axis shall be marked on the end of the unit using a pencil or marker having a marking width of not greater than 0.05 in. (1.3 mm). A tamping rod used for consolidation of concrete and grout for slump tests performed in accordance with Test Method C 143 is often used as a balancing rod.

6.4.2 Moisture Condition of Specimens—At the time the specimens are tested, they shall be free of visible moisture or dampness.

6.4.3 Speed of Testing—Apply the load up to one half of the expected maximum load at any convenient rate, after which adjust the controls of the machine as required to give a uniform rate of travel of the moving head such that the remaining load is applied in not less than 1 nor more than 2 min.

6.4.4 Maximum Load—Record the maximum compressive load in pounds (newtons) as P_{max} .

7. Flexural Load on Concrete Roof Pavers

7.1 Three full-size units shall be tested.

7.2 Capping—Units with wearing (top) surfaces containing recesses or other irregularities shall have such recesses capped flush with the uppermost surface by either the sulfur and granular method or the gypsum cement casting method in accordance with 6.3.

7.3 Testing—The testing arrangement shall be as shown in

Fig. 2. The load from the upper bearing block of the testing machine shall be applied through the centroid of the concrete roof paver by the bearing assembly illustrated. The flexural length of the paver units is taken as the end to end plan dimension of the units. Loading shall be applied at a uniform rate such that the total load is applied in not less than one min and not more than 3 min.

8. Absorption

8.1 Apparatus—The balance used shall be sensitive to within 0.5 % of the weight of the smallest specimen tested.

8.2 Test Specimens—Three full-size units that have been marked, weighed, and recorded in accordance with 4.3.2 shall be used. Tests shall be performed on full-size units when test results are to be used to determine moisture content in accordance with 9.2 or equivalent thickness in accordance with 9.7.

8.2.1 Tests shall be performed on full-size units or specimens saw-cut from full-size units. Calculated values for absorption and density of reduced-size absorption specimens shall be considered as representative of the whole unit. The reason reduced-size absorption specimens were used shall be included in the test report.

8.3 Procedure:

8.3.1 Saturation—Immerse the test specimens in water at a temperature of 60 to 80°F (15.6 to 26.7°C) for 24 h. Weigh the specimens while suspended by a metal wire and completely submerged in water and record W_i (immersed weight). Remove from the water and allow to drain for 1 min by placing them on a 3/8-in. (9.5-mm) or coarser wire mesh, removing visible surface water with a damp cloth; weigh and record as W_s (saturated weight).

8.3.2 Drying—Subsequent to saturation, dry all specimens in a ventilated oven at 212 to 239°F (100 to 115°C) for not less than 24 h and until two successive weighings at intervals of 2 h show an increment of loss not greater than 0.2 % of the last previously determined weight of the specimen. Record weight of dried specimens as W_d (oven-dry weight).

9. Calculations

9.1 Absorption—Calculate absorption as follows:

$$\begin{aligned} \text{Absorption, lb/ft}^3 &= [(W_s - W_d)/(W_s - W_i)] \times 62.4 \\ \text{Absorption, kg/m}^3 &= [(W_s - W_d)/(W_s - W_i)] \times 1000 \\ \text{Absorption, \%} &= [(W_s - W_d)/W_d] \times 100 \end{aligned} \tag{1}$$

where:

- W_s = saturated weight of specimen, lb (kg) (see 8.3.1),
- W_i = immersed weight of specimen, lb (kg) (see 8.3.1),
- and
- W_d = oven-dry weight of specimen, lb (kg) (see 8.3.2).

9.2 Moisture Content— Calculate the moisture content as follows:

$$\text{Moisture Content, \% of total absorption} = [(W_r - W_d)/(W_s - W_d)] \times 100 \tag{2}$$

where:

- W_r = received weight of unit, lb (kg) (see 4.3.2),
- W_d = oven-dry weight of unit, lb (kg) (see 8.3.2), and

W_s = saturated weight of unit, lb (kg) (see 8.3.1).

9.3 *Density*—Calculate oven-dry density as follows:

$$\text{Density (D), lb/ft}^3 = [W_d/(W_s - W_i)] \times 62.4 \quad (3)$$

$$\text{Density (D), kg/m}^3 = [W_d/(W_s - W_i)] \times 1000$$

where:

W_d = oven-dry weight of specimen, lb (kg) (see 8.3.2),
 W_s = saturated weight of specimen, lb (kg) (see 8.3.1), and
 W_i = immersed weight of specimen, lb (kg) (see 8.3.1).

9.4 *Average Net Area*—Calculate average net area as follows:

$$\text{Net Volume (V}_n\text{), ft}^3 = W_d/D = (W_s - W_i)/62.4$$

$$\text{Net Volume (V}_n\text{), mm}^3 = W_d/D = (W_s - W_i) \times 10^6 \quad (4)$$

$$\text{Average Net Area (A}_n\text{), in.}^2 = (V_n \times 1728)/H$$

$$\text{Average Net Area (A}_n\text{), mm}^2 = V_n/H$$

where:

V_n = net volume of specimen, ft³(mm³),
 W_d = oven-dry weight of specimen, lb (kg) (see 8.3.2),
 D = oven-dry density of specimen, lb/ft³(kg/m³) (see 9.3),
 W_s = saturated weight of specimen, lb (kg) (see 8.3.1),
 W_i = immersed weight of specimen, lb (kg) (see 8.3.1),
 A_n = average net area of specimen, in.²(mm²), and
 H = average height of specimen, in. (mm) (see 5.3.2).

9.4.1 Except for irregularly shaped specimens, such as those with split surfaces, calculate the net area of coupons and those specimens whose net cross-sectional area in every plane parallel to the bearing surface is the gross cross-sectional area measured in the same plane, as follows:

$$\text{Net Area (A}_n\text{), in.}^2 \text{ (mm}^2\text{)} = L \times W \quad (5)$$

where:

A_n = net area of the coupon or specimen, in.²(mm²),
 L = average length of the coupon or specimen, in. (mm) (see 5.3.1), and
 W = average width of the coupon or specimen, in. (mm) (see 5.3.1)

9.5 *Gross Area*—Calculate gross area as follows:

$$\text{Gross Area (A}_g\text{), in.}^2 \text{ (mm}^2\text{)} = L \times W \quad (6)$$

where:

A_g = gross area of the specimen, in.²(mm²),
 L = average length of the specimen, in. (mm) (see 5.3.2), and
 W = average width of the specimen, in. (mm) (see 5.3.2).

The gross cross-sectional area of a specimen is the total area of a section perpendicular to the direction of the load, including areas within cells and reentrant spaces, unless these spaces are to be occupied in the masonry by portions of adjacent masonry.

9.6 *Compressive Strength*:

9.6.1 *Net Area Compressive Strength*—Calculate the net area compressive strength of the specimen as follows:

$$\text{Net Area Compressive Strength, psi (MPa)} = P_{\max}/A_n \quad (7)$$

where:

P_{\max} = maximum compressive load, lb (N) (see 6.4.3), and

A_n = average net area of specimen, in.²(mm²) (see 9.4).

9.6.2 *Gross Area Compressive Strength*—Calculate the gross area compressive strength of the specimen as follows:

$$\text{Gross Area Compressive Strength, psi (MPa)} = P_{\max}/A_g \quad (8)$$

where:

P_{\max} = maximum compressive load, lb (N) (see 6.4.3), and

A_g = gross area of specimen, in.²(mm²) (see 9.5).

9.6.3 *Corrected Net Area Compressive Strength for Segmental Retaining Wall Unit Test Specimens*—Multiply the calculated net area compressive strength of each specimen by the height to thickness ratio correction factor.

9.7 *Equivalent Web Thickness*—Equivalent web thickness of each unit (in inches per linear foot of specimen) is equal to the sum of the measured thicknesses of all webs whose individual thickness is equal to or greater than 0.75 in. (19.1 mm) in the unit multiplied by 12 and divided by the length of the unit.

NOTE 11—Equivalent web thickness does not apply to the portion of the unit to be filled with grout. The length of that portion should be deducted from the overall length of the unit.

9.8 *Equivalent Thickness*—Equivalent thickness for concrete masonry is defined as the average thickness of solid material in the unit and is calculated as follows:

$$T_e, \text{ in.} = [V_n/(L \times H)] \times 1728 \quad (9)$$

$$T_e, \text{ mm} = [V_n/(L \times H)]$$

where:

T_e = equivalent thickness, in. (mm),
 V_n = average net volume of full-size units, ft³(mm³) (see 9.4),
 L = average length of full-size units, in. (mm) (see 5.3.2), and
 H = average height of full-size units, in. (mm) (see 5.3.2).

9.9 *Ballast Weight*— For concrete roof pavers, calculate ballast weight as follows:

$$W_b \text{ (lb/ft}^2\text{)} = \frac{W_d}{A_g} \times 144 \quad (10)$$

$$W_b \text{ (kg/m}^2\text{)} = \frac{W_d}{A_g} \times 10^6$$

where:

W_b = ballast weight, lb/ft²(kg/m²),
 W_d = oven-dry weight of unit, lb (kg) (see 8.3.2), and
 A_g = gross area of unit, in.²(mm²) (see 9.5)

10. Report

10.1 A complete report shall include the following:

10.1.1 The net area compressive strength to the nearest 10 psi (0.1 MPa) separately for each specimen and as the average for three specimens as determined by 9.6.1.

10.1.1.1 For segmental retaining wall units, report the tested net area compressive strength to the nearest 10 psi (0.1 MPa),

the height to thickness ratio, and the corrected net area compressive strength separately for each specimen as determined by 9.6. Also, report the average corrected net area compressive strength for the set of three specimens.

10.1.2 The absorption and density results to the nearest 0.1 pcf (1 kg/m³) or 0.1% and density results to the nearest 0.1 pcf (1 kg/m³) separately for each unit and as the average for the three units as determined by 9.1 and 9.3. If absorption tests are performed on specimens other than full-size units, report the reason for testing reduced-size units and the size and configuration of the specimens tested.

10.1.3 The average width, height, and length to the nearest 0.1 in. (2.5 mm) of each specimen as determined by 5.3.2.

10.1.4 The minimum face shell thickness to the nearest 0.01 in. (0.25 mm) as an average of the minimum face shell thicknesses recorded for each of three specimens as determined by 5.3.2.

10.1.5 The minimum web thickness to the nearest 0.1 in. (2.5 mm) as an average of the minimum web thicknesses recorded for each of three specimens as determined by 5.3.2.

10.1.6 The equivalent web thickness to the nearest 0.1 in. (2.5 mm) as an average for three specimens as determined by 9.7.

10.1.7 The equivalent thickness to the nearest 0.1 in. (2.5 mm) as an average for three specimens as determined by 9.8 when required.

10.1.8 The moisture content to the nearest 0.1% as an average for three specimens as determined by 9.2 when required.

10.1.9 *Flexural Strength of Concrete Roof Pavers*—Report the flexural load to the nearest 1 lb (5 N) required to fail a unit separately and as an average for three units.

10.1.10 *Ballast Weight of Concrete Roof Pavers*—Report the ballast weight to the nearest 1 psf (5 kg/m²).

11. Keywords

11.1 absorption; compressive strength; concrete masonry units; density; equivalent thickness; equivalent web thickness; face shell; moisture content; roof paver; web thickness; webs

ANNEX

(Mandatory Information)

A1. DETERMINING PLATE THICKNESS REQUIREMENTS FOR COMPRESSION TESTING

A1.1 *Scope*—This annex provides additional information to assist in determining the plate thickness requirements for compression testing as written in 6.1.

A1.2 *Terminology*—Fig. A1.1 shows the location of the referenced test equipment as used in the compression testing of units.

A1.3 *Determining the Diameter of the Upper Platen*—As shown in Fig. A1.2, the diameter of the upper platen is considered in this test method to be equal to the maximum horizontal dimension measured across the circle created by the spherical portion of the upper platen (this measured diameter

may differ from the actual geometric diameter of the sphere based on its curvature). If the upper platen includes a nonspherical section that was manufactured integrally with the spherical head from a single piece of steel, the diameter of the upper platen is considered to be the diameter of the spherical seat on the upper surface of the upper platen plus the thickness of the nonspherical section (t_{PL}). However, the diameter of the upper platen shall not be greater than the minimum horizontal dimension of the upper platen.

A1.4 *Distance from the Edge of Platen to Furthest Corner of Test Specimen*—(See Fig. A1.3.) Determine the distance from the edge of the platen to the furthest corner

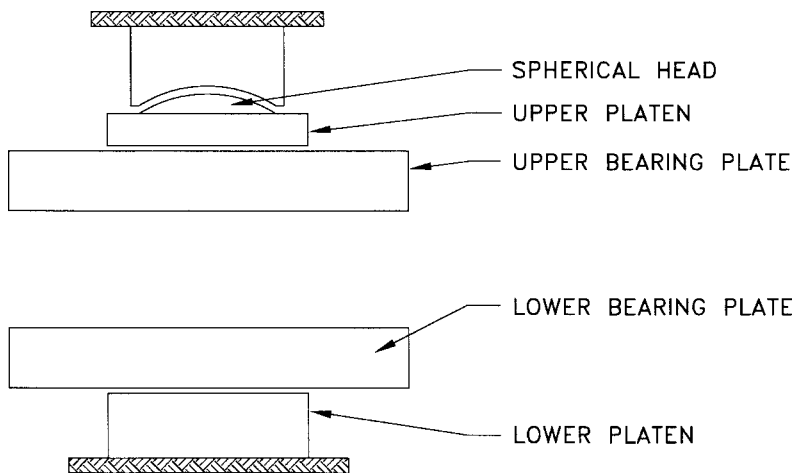

FIG. A1.1 Equipment Used for Compression Testing