



Standard Practice for Installing Vitrified Clay Pipe Lines¹

This standard is issued under the fixed designation C 12; the number immediately following the designation indicates the year of original adoption or, in the case of revision, the year of last revision. A number in parentheses indicates the year of last reapproval. A superscript epsilon (ϵ) indicates an editorial change since the last revision or reapproval.

This standard has been approved for use by agencies of the Department of Defense.

1. Scope

1.1 This practice covers the proper methods of installing vitrified clay pipe lines in order to fully utilize the structural properties of such pipe.

1.2 The values stated in inch-pound units are to be regarded as the standard. The values given in parentheses are for information only.

1.3 *This standard does not purport to address all of the safety concerns, if any, associated with its use. It is the responsibility of the user of this standard to establish appropriate safety and health practices and determine the applicability of regulatory limitations prior to use.*

2. Referenced Documents

2.1 ASTM Standards:

- C 301 Test Methods for Vitrified Clay Pipe²
- C 425 Specification for Compression Joints for Vitrified Clay Pipe and Fittings²
- C 700 Specification for Vitrified Clay Pipe, Extra Strength, Standard Strength, and Perforated²
- C 828 Test Method for Low-Pressure Air Test of Vitrified Clay Pipe Lines²
- C 896 Terminology Relating to Clay Products²
- C 1091 Test Methods for Hydrostatic Infiltration and Exfiltration Testing of Vitrified Clay Pipe Lines²

3. Terminology

3.1 *General*—Terminology C 896 can be used for clarification of terminology in this specification.

DESIGN CONSIDERATIONS

4. Supporting Strength

4.1 The field supporting strength of vitrified clay pipe is materially affected by the methods of installation. The field supporting strength of a pipe is defined as its capacity to support dead and live loads under actual field conditions. It is

dependent upon two factors: (1) the inherent strength of the pipe and (2) the bedding of the pipe.

4.2 The minimum bearing strength requirement in accordance with Specification C 700, as determined by the 3-edge-bearing test of Test Methods C 301, is a measure of the inherent strength of the pipe.

4.3 The tests used to measure bearing strength determine relative pipe strengths but do not represent actual field conditions. Therefore, an adjustment called a load factor is introduced to convert minimum bearing strength to field supporting strength. The magnitude of the load factor depends on how the pipe is bedded. The relationship is:

Field supporting strength = minimum bearing strength \times load factor

4.4 A factor of safety greater than 1.0 and less than or equal to 1.5 shall be applied to the field supporting strength to calculate a safe supporting strength. The relationship is:

$$\text{Safe supporting strength} = \frac{\text{Field supporting strength}}{\text{Factor of safety}}$$

5. External Loads

5.1 The external loads on installed vitrified clay pipe are of two general types: (1) dead loads and (2) live loads.

5.2 For pipes installed in trenches at a given depth, the dead load increases as the trench width, measured at the top of the pipe, increases. Consequently, the trench width at the top of the pipe shall be kept as narrow as possible. Pipe failure may result if the design trench width is exceeded. If the trench width exceeds the design width, a higher class of bedding, stronger pipe, or both, must be investigated.

5.3 Live loads that act at the ground surface are partially transmitted to the pipe. Live loads may be produced by wheel loading, construction equipment or by compactive effort. Compaction of embedment and backfill materials, beside and above the sewer pipe, produces a temporary live load on the pipe. The magnitude of the live load from compactive effort varies with soil type, degree of saturation, degree of compaction and depth of cover over the pipe. Care must be used in selection of compaction methods so that the combined dead load and live load does not exceed the field supporting strength of the pipe, or cause a change in its line or grade.

NOTE 1—For generally accepted criteria and methods for determining loads and supporting strengths, see *Gravity Sanitary Sewer Design and*

¹ This practice is under the jurisdiction of ASTM Committee C04 on Vitrified Clay Pipe and is the direct responsibility of Subcommittee C04.20 on Methods of Test and Specifications.

Current edition approved Aug. 10, 2000. Published September 2000. Originally published as C 12–15T. Last previous edition C 12–98^{ε1}.

² *Annual Book of ASTM Standards*, Vol 04.05.

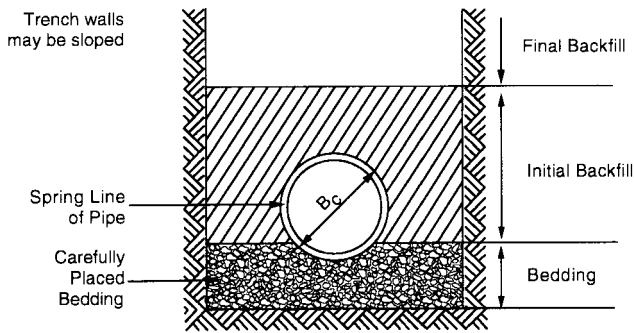

TRENCH CROSS SECTION

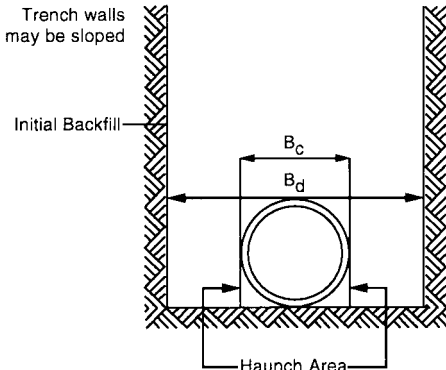

B_c = the outside diameter of the pipe barrel.
 B_d = the design trench width measured at the horizontal plane at the top of the pipe barrel.

FIG. 1 Terminology

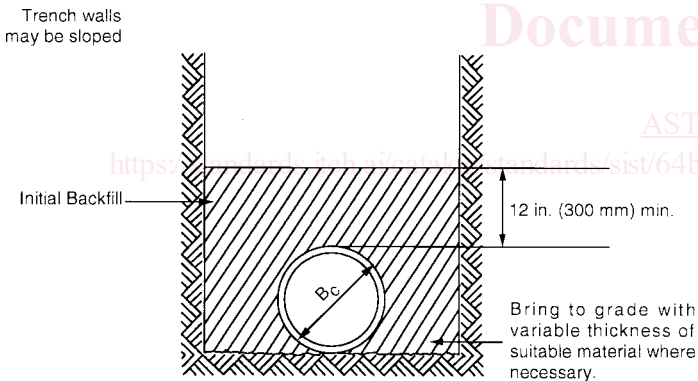

Load Factor: 1.1

Flat or Restored Trench Bottom

FIG. 2 Class D

Construction, Water Pollution Control Federation Manual of Practice No. FD-5, American Society of Civil Engineers—Manuals and Report on Engineering Practice—No. 60.³

6. Bedding and Encasement

6.1 Classes of bedding and encasements for pipe in trenches are defined herein. The load factors indicated are for conversion of minimum bearing strength to field supporting strength.

6.2 Class D (Fig. 2)—The pipe shall be placed on the trench bottom with bell holes provided (Fig. 9). The initial backfill

shall be of selected material (Note 2).

6.2.1 The load factor for Class D bedding is 1.1.

NOTE 2—Selected material is finely divided material free of debris, organic material, and large stones.

6.3 Class C (Fig. 3)—The pipe shall be bedded in carefully placed material (Note 3). However, shells, pea gravel, sand (see Note 4), or other locally available and commonly used bedding materials may be specified by the engineer in place of the previously described materials. The bedding shall have a minimum thickness beneath the pipe of 4 in. (100 mm) or one eighth of the outside diameter of the pipe, whichever is greater, and shall extend up the haunches of the pipe one sixth of the outside diameter of the pipe. The initial backfill shall be of selected material (Note 2).

6.3.1 The load factor for Class C bedding is 1.5.

NOTE 3—“Carefully placed” material shall mean material that has been spaded or shovel-sliced so that the material fills and supports the haunch area and encases the pipe to the limits shown in the trench diagrams (Figs. 1-8). This practice calls special attention to the desirability of using well-graded 3/4 to 1/4 in. (19 to 6 mm) crushed stone or other non-consolidating bedding material not subject to migration. Where crushed material is not readily available, locally available and commonly used materials are acceptable, if used with engineering judgment as to their ability to provide adequate pipe support.

NOTE 4—Sand is suitable as a bedding material in a total sand environment but may be unsuitable where high and rapidly changing water tables are present in the pipe zone. It may also be undesirable for bedding, or haunching in a trench cut by blasting or in trenches through clay type soil. Regardless of the trench condition or bedding class, the maximum load factor for sand bedding is 1.5.

6.4 Class B (Fig. 4)—The pipe shall be bedded in carefully placed material (Note 3). The bedding shall have a minimum thickness beneath the pipe of 4 in. (100 mm) or one eighth of the outside diameter of the pipe, whichever is greater, and shall extend up the haunches of the pipe to the springline. The initial backfill shall be of selected material (Note 2).

6.4.1 The load factor for Class B bedding is 1.9.

6.5 Crushed Stone Encasement (Fig. 5)—There are specific sites where crushed stone encasement may be desirable. The crushed stone shall extend to the specified trench width and shall have a minimum thickness beneath the pipe of 4 in. (100 mm) or one eighth of the outside diameter of the pipe, whichever is greater, and shall extend upward to a horizontal plane at the top of the pipe barrel, (Note 5). Encasement shall consist of well-graded 3/4 to 1/4 in. (19 to 6 mm) crushed stone or other non-consolidating bedding material not subject to migration. Material shall be carefully placed under the pipe haunches (Note 3). The initial backfill shall be of selected material.

NOTE 5—**Caution:** Sufficient crushed stone shall be placed so that the bedding extends to a horizontal plane at the top of the pipe barrel following removal of any trench sheeting or boxes.

6.5.1 The load factor for crushed stone encasement is 2.2.

6.6 Controlled Low Strength Material (Fig. 6)—Controlled low strength material has been shown to be an economic alternative to compacted bedding material. It assists in utilizing the inherent strength of the pipe, completely filling the haunch area, and reducing the trench load on the pipe.

6.6.1 The pipe shall be bedded on crushed stone or other

³ Available from American Society of Civil Engineers, 345 E. 47th Street, New York, NY 10017.

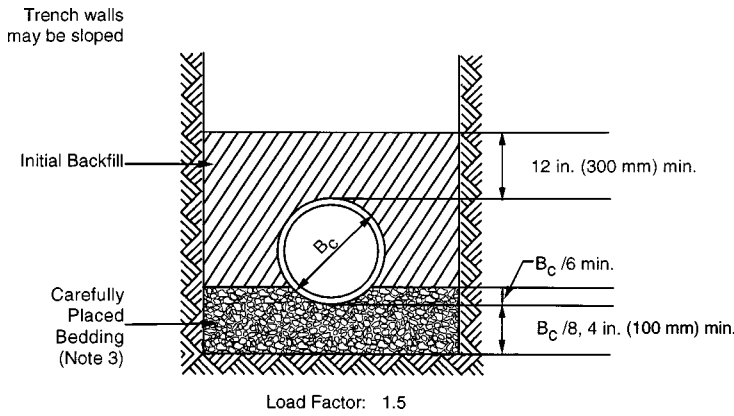

Load Factor: 1.5

FIG. 3 Class C

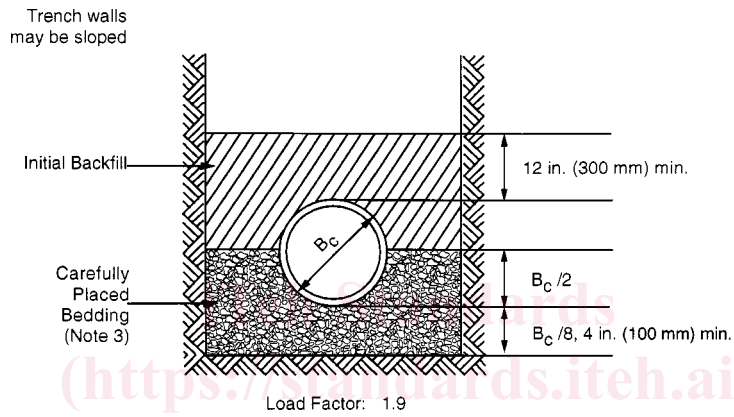

Load Factor: 1.9

FIG. 4 Class B

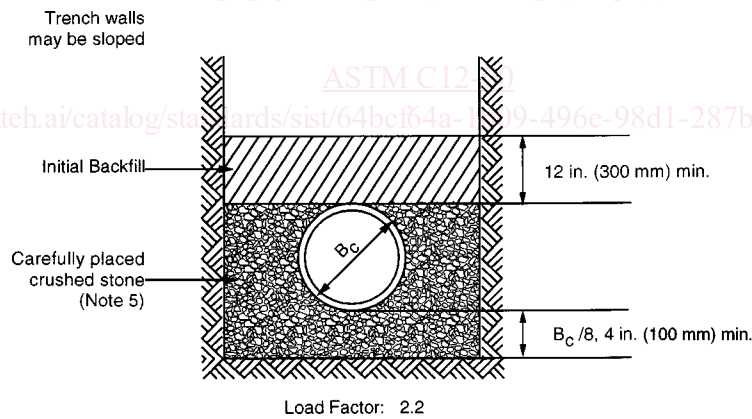

Load Factor: 2.2

FIG. 5 Crushed Stone Encasement

suitable material (Note 4). The bedding shall have a minimum thickness beneath the pipe of 4 in. (100 mm) or one eighth of the outside diameter of the pipe, whichever is greater. Controlled low strength material shall be directed to the top of the pipe to flow down on both sides to prevent misalignment. Fill to the top of the pipe. The initial backfill may be placed when the pour is capable of supporting the backfill material without intermixing.

NOTE 6—Attention is directed to terminology and material references. See *American Concrete Institute Report: ACI 229R-94 Controlled Low*

*Strength Materials (CLSM).*⁴

6.6.2 The load factor for controlled low strength material is 2.8.

6.7 *Class A*—This class of bedding can be achieved with either of two construction methods.

6.7.1 *Concrete Cradle* (Fig. 7)—The pipe shall be bedded in a monolithic cradle of reinforced concrete having a thickness

⁴ Available from American Concrete Institute, P.O. Box 19150, Detroit, MI 48219-0150.