

INTERNATIONAL STANDARD

NORME INTERNATIONALE



**Industrial communication networks – Profiles –
Part 3-6: Functional safety fieldbuses – Additional specifications for CPF 6**

**Réseaux de communications industriels – Profils –
Partie 3-6: Bus de terrain de sécurité fonctionnelle – Spécifications
supplémentaires pour la CPF 6**

<https://standards.iteh.ai/standards/iec/2eb476c3-84cd-4e52-bc79-1b0011fd0b0c/iec-61784-3-6-2007>

<https://standards.iteh.ai/standards/iec/2eb476c3-84cd-4e52-bc79-1b0011fd0b0c/iec-61784-3-6-2007>



THIS PUBLICATION IS COPYRIGHT PROTECTED
Copyright © 2007 IEC, Geneva, Switzerland

All rights reserved. Unless otherwise specified, no part of this publication may be reproduced or utilized in any form or by any means, electronic or mechanical, including photocopying and microfilm, without permission in writing from either IEC or IEC's member National Committee in the country of the requester.
If you have any questions about IEC copyright or have an enquiry about obtaining additional rights to this publication, please contact the address below or your local IEC member National Committee for further information.

Droits de reproduction réservés. Sauf indication contraire, aucune partie de cette publication ne peut être reproduite ni utilisée sous quelque forme que ce soit et par aucun procédé, électronique ou mécanique, y compris la photocopie et les microfilms, sans l'accord écrit de la CEI ou du Comité national de la CEI du pays du demandeur.
Si vous avez des questions sur le copyright de la CEI ou si vous désirez obtenir des droits supplémentaires sur cette publication, utilisez les coordonnées ci-après ou contactez le Comité national de la CEI de votre pays de résidence.

IEC Central Office
3, rue de Varembe
CH-1211 Geneva 20
Switzerland

Tel.: +41 22 919 02 11
Fax: +41 22 919 03 00
info@iec.ch
www.iec.ch

About the IEC

The International Electrotechnical Commission (IEC) is the leading global organization that prepares and publishes International Standards for all electrical, electronic and related technologies.

About IEC publications

The technical content of IEC publications is kept under constant review by the IEC. Please make sure that you have the latest edition, a corrigenda or an amendment might have been published.

Useful links:

IEC publications search - www.iec.ch/searchpub

The advanced search enables you to find IEC publications by a variety of criteria (reference number, text, technical committee,...).

It also gives information on projects, replaced and withdrawn publications.

IEC Just Published - webstore.iec.ch/justpublished

Stay up to date on all new IEC publications. Just Published details all new publications released. Available on-line and also once a month by email.

Electropedia - www.electropedia.org

The world's leading online dictionary of electronic and electrical terms containing more than 30 000 terms and definitions in English and French, with equivalent terms in additional languages. Also known as the International Electrotechnical Vocabulary (IEV) on-line.

Customer Service Centre - webstore.iec.ch/csc

If you wish to give us your feedback on this publication or need further assistance, please contact the Customer Service Centre: csc@iec.ch.

A propos de la CEI

La Commission Electrotechnique Internationale (CEI) est la première organisation mondiale qui élabore et publie des Normes internationales pour tout ce qui a trait à l'électricité, à l'électronique et aux technologies apparentées.

A propos des publications CEI

Le contenu technique des publications de la CEI est constamment revu. Veuillez vous assurer que vous possédez l'édition la plus récente, un corrigendum ou amendement peut avoir été publié.

Liens utiles:

Recherche de publications CEI - www.iec.ch/searchpub

La recherche avancée vous permet de trouver des publications CEI en utilisant différents critères (numéro de référence, texte, comité d'études,...).

Elle donne aussi des informations sur les projets et les publications remplacées ou retirées.

Just Published CEI - webstore.iec.ch/justpublished

Restez informé sur les nouvelles publications de la CEI. Just Published détaille les nouvelles publications parues. Disponible en ligne et aussi une fois par mois par email.

Electropedia - www.electropedia.org

Le premier dictionnaire en ligne au monde de termes électroniques et électriques. Il contient plus de 30 000 termes et définitions en anglais et en français, ainsi que les termes équivalents dans les langues additionnelles. Egalement appelé Vocabulaire Electrotechnique International (VEI) en ligne.

Service Clients - webstore.iec.ch/csc

Si vous désirez nous donner des commentaires sur cette publication ou si vous avez des questions contactez-nous: csc@iec.ch.

INTERNATIONAL STANDARD

NORME INTERNATIONALE



**Industrial communication networks – Profiles –
Part 3-6: Functional safety fieldbuses – Additional specifications for CPF 6**

**Réseaux de communications industriels – Profils –
Partie 3-6: Bus de terrain de sécurité fonctionnelle – Spécifications
supplémentaires pour la CPF 6**

INTERNATIONAL
ELECTROTECHNICAL
COMMISSION

COMMISSION
ELECTROTECHNIQUE
INTERNATIONALE

PRICE CODE **XC**
CODE PRIX

ICS 25.040; 35.100.05

ISBN 978-2-8322-0845-8

**Warning! Make sure that you obtained this publication from an authorized distributor.
Attention! Veuillez vous assurer que vous avez obtenu cette publication via un distributeur agréé.**

CONTENTS

FOREWORD.....	7
INTRODUCTION.....	9
1 Scope.....	12
2 Normative references.....	12
3 Terms, definitions, symbols, abbreviated terms and conventions.....	13
3.1 Terms and definitions.....	13
3.1.1 Common terms and definitions.....	13
3.1.2 CPF 6: Additional terms and definitions.....	17
3.2 Symbols and abbreviated terms.....	18
3.2.1 Common symbols and abbreviated terms.....	18
3.2.2 CPF 6: Additional symbols and abbreviated terms.....	18
3.3 Conventions.....	19
4 Overview of FSCP 6/7 (INTERBUS™ Safety).....	19
4.1 General.....	19
4.2 Technical overview.....	19
4.3 Functional Safety Communication Profile 6/7.....	20
5 General.....	21
5.1 External documents providing specifications for the profile.....	21
5.2 Safety functional requirements.....	21
5.3 Safety measures.....	21
5.3.1 General.....	21
5.3.2 Sequence number.....	22
5.3.3 Time stamp.....	22
5.3.4 Time expectation.....	22
5.3.5 Acknowledgement.....	22
5.3.6 Connection authentication.....	22
5.3.7 Distinction between safety relevant messages and non-safety relevant messages – different data integrity assurance system.....	23
5.3.8 Parameterized shutdown time.....	23
5.4 Safety communication layer structure.....	23
5.4.1 Decomposition process.....	23
5.4.2 Definition of the safety function of the safety communication system.....	24
5.4.3 Decomposition of the safety function of a safety communication system into function blocks.....	25
5.4.4 Assignment of the function blocks to subsystems.....	26
5.4.5 Safety requirements and safety integrity requirements.....	29
5.4.6 Specification of the safe state.....	29
5.4.7 Response to a fault.....	30
5.4.8 Stop category.....	32
5.4.9 Safe Transmission.....	32
5.5 Relationships with FAL (and DLL, PhL).....	33
5.5.1 Overview.....	33
5.5.2 Use of the AR-US service to initiate and parameterize.....	33
5.5.3 Use of the AR-US service to transmit safety data.....	34
5.5.4 Use of the AR-US service to abort.....	35
5.5.5 Data types.....	35

6	Safety communication layer services	35
6.1	General	35
6.2	Transmission principle for safety messages between SCLM and SCLS	35
6.3	Function block requirements	36
6.3.1	Input Safe Data function block	36
6.3.2	Output Safe Data function block	36
6.3.3	Safe Calculation function block	36
6.4	Context management	37
6.4.1	Initiate service	37
6.4.2	Abort service	38
6.5	Function block parameterization	39
6.5.1	Send application parameter service	39
6.5.2	Send application parameter ID service	40
6.5.3	Parameterize device service	41
6.6	Safe Process Data Mode	41
6.6.1	Transmit-Safety-Data	41
6.6.2	Set-Diagnostic-Data service	43
6.6.3	Set-Acknowledgement-Data service	43
7	Safety communication layer protocol	44
7.1	Safety PDU format	44
7.1.1	Structure of safety messages	44
7.1.2	Description of the polynomial used	45
7.1.3	Structure of safety messages for safe parameterization and idle	45
7.1.4	Structure of safety messages for the transmission of safety data	51
7.1.5	Messages for synchronization	52
7.1.6	Structure of safety messages for aborting connections	53
7.2	State description	54
7.2.1	SCLM and SCLS state machines	54
7.2.2	Initiate	55
7.2.3	Parameterization	56
7.2.4	Process data mode	59
7.2.5	Process data mode with diagnostic data transmission	64
7.2.6	Process data mode with Acknowledgement-Data transmission	65
7.2.7	Connection aborted	66
7.3	Abort	66
7.3.1	Connection abort in the event of an error detected by the SCLM	66
7.3.2	Abort of all connections in the event of an error detected by the SCLS	67
7.3.3	Abort of all connections in the event of an error detected by the SCLM	69
8	Safety communication layer management	70
8.1	General	70
8.2	Requirements of safety communication layer management	70
8.3	Set-Safety-Configuration service	70
8.4	Start IEC 61158 Type 8 service	72
9	System requirements	72
9.1	Indicators and switches	72
9.2	Installation guidelines	72
9.3	Safety function response time	72

9.3.1	General	72
9.3.2	Calculation of the parameterized shutdown time	73
9.4	Duration of demands	77
9.5	Constraints for calculation of system characteristics	77
9.5.1	System characteristics	77
9.5.2	Calculation of the number of telegrams per second	77
9.6	Maintenance	78
9.7	Safety manual	79
10	Certification	79
	Bibliography	80

Table 1	– Overview of profile identifier usable for FSCP 6/7	21
Table 2	– Selection of the various measures for possible errors	22
Table 3	– List of function blocks and subsystems	26
Table 4	– Signal flow between the function blocks	28
Table 5	– Initiate service parameters	37
Table 6	– Parameterization mode and related services	38
Table 7	– Abort service parameters	38
Table 8	– Abort of a point-to-point connection by the SRP or SRC	39
Table 9	– Send application parameter service	39
Table 10	– Send application parameter ID service	40
Table 11	– Parameterize device parameters	41
Table 12	– Transmit-Safety-Data service parameters	42
Table 13	– Set-Diagnostic-Data service parameters	43
Table 14	– Set-Acknowledgement-Data service parameters	44
Table 15	– Parameter ID	47
Table 16	– Block 0: Device ID	48
Table 17	– Block 1: Parameter record ID	49
Table 18	– Block 2: Application parameter	49
Table 19	– TIME encoding	52
Table 20	– Abort_Info: Connection abort in the event of an error detected by the SCLM	67
Table 21	– Abort_Info: Abort of all connections in the event of an error detected by the SCLS	68
Table 22	– Abort_Info: Abort of all connections in the event of an error detected by the SCLM	70
Table 23	– Set-Safety-Configuration service	71
Table 24	– Error_Info	71
Table 25	– Calculation of t_{IB}	76
Table 26	– Calculation of t_{SRC}	77
Table 27	– Calculation of t_{PST}	77

Figure 1 – Relationships of IEC 61784-3 with other standards (machinery) 9

Figure 2 – Relationships of IEC 61784-3 with other standards (process) 10

Figure 3 – FSCP 6/7 communication preconditions	20
Figure 4 – Example of a safety function	24
Figure 5 – Decomposition of safety function into function blocks	25
Figure 6 – Overview of the results of the decomposition process	27
Figure 7 – Signal flow between the function blocks	27
Figure 8 – Interfaces between the safety devices within the safety communication system	28
Figure 9 – Signal flow and safe states	30
Figure 10 – Mapping of the Safe Transmission function block	32
Figure 11 – Relationship between SCL and the other layers of IEC 61158 Type 8	33
Figure 12 – Use of the AR-US service to initiate and parameterize	34
Figure 13 – Use of the AR-US service to transmit safety data	34
Figure 14 – Use of the AR-US service to abort	35
Figure 15 – Use of the AR-US service to abort	35
Figure 16 – Structure of the safety PDU	44
Figure 17 – Integration of safety data and deterministic remedial measures in the summation frame	45
Figure 18 – Write_Parameter_Byte_Req message	46
Figure 19 – Read_Parameter_Byte_Req message	46
Figure 20 – Parameter_Byte_Con message	46
Figure 21 – Set_Safety_Connection_ID_Req message	50
Figure 22 – Set_Safety_Connection_ID_Con message of safety slaves	50
Figure 23 – Parameter_Idle_Req	50
Figure 24 – Parameter_Idle_Con	50
Figure 25 – Parameter_Check_Con	51
Figure 26 – Parameter_Loc_ID_Changed_Con	51
Figure 27 – Transmit Safety Data Message	51
Figure 28 – Sync_a message of the SCLM	52
Figure 29 – Req_b message of the SCLM	53
Figure 30 – Req_c message of the SCLM	53
Figure 31 – Req_d message of the SCLM	53
Figure 32 – Abort_Connection message	54
Figure 33 – Safety-Slave_Error message	54
Figure 34 – SCLM state machine	54
Figure 35 – SCLS state machine	55
Figure 36 – Initiate sequence	56
Figure 37 – Send Application Parameter sequence	57
Figure 38 – Send Application Parameter ID sequence	58
Figure 39 – Parameterize device sequence	59
Figure 40 – Simultaneous transmission of safety data to the safety slaves	60
Figure 41 – Use of the sequence number in the SCLM and SCLS	61
Figure 42 – Startup and error-free operation	62
Figure 43 – Resynchronization during operation	63
Figure 44 – Invalid CRC 24 checksum detected by the SCLS	64

Figure 45 – Process data mode with diagnostic data transmission	65
Figure 46 – Process data mode with Acknowledgement-Data transmission	66
Figure 47 – Error when initiating a connection	67
Figure 48 – Error at an SCLS when aborting all connections.....	68
Figure 49 – Abort of all connections in the event of an error detected by the SCLM	69
Figure 50 – Overview of the shutdown time.....	74

Witholdawn

iTech Standards
(<https://standards.iteh.ai>)
Document Preview

<https://standards.iteh.ai> IEC 61784-3-6:2007

<https://standards.iteh.ai/catalog/standards/iec/2eb476c3-84cd-4e52-bc79-1b0011fd0b0c/iec-61784-3-6-2007>

INTERNATIONAL ELECTROTECHNICAL COMMISSION

INDUSTRIAL COMMUNICATION NETWORKS –
PROFILES –Part 3-6: Functional safety fieldbuses –
Additional specifications for CPF 6

FOREWORD

- 1) The International Electrotechnical Commission (IEC) is a worldwide organization for standardization comprising all national electrotechnical committees (IEC National Committees). The object of IEC is to promote international co-operation on all questions concerning standardization in the electrical and electronic fields. To this end and in addition to other activities, IEC publishes International Standards, Technical Specifications, Technical Reports, Publicly Available Specifications (PAS) and Guides (hereafter referred to as "IEC Publication(s)"). Their preparation is entrusted to technical committees; any IEC National Committee interested in the subject dealt with may participate in this preparatory work. International, governmental and non-governmental organizations liaising with the IEC also participate in this preparation. IEC collaborates closely with the International Organization for Standardization (ISO) in accordance with conditions determined by agreement between the two organizations.
- 2) The formal decisions or agreements of IEC on technical matters express, as nearly as possible, an international consensus of opinion on the relevant subjects since each technical committee has representation from all interested IEC National Committees.
- 3) IEC Publications have the form of recommendations for international use and are accepted by IEC National Committees in that sense. While all reasonable efforts are made to ensure that the technical content of IEC Publications is accurate, IEC cannot be held responsible for the way in which they are used or for any misinterpretation by any end user.
- 4) In order to promote international uniformity, IEC National Committees undertake to apply IEC Publications transparently to the maximum extent possible in their national and regional publications. Any divergence between any IEC Publication and the corresponding national or regional publication shall be clearly indicated in the latter.
- 5) IEC provides no marking procedure to indicate its approval and cannot be rendered responsible for any equipment declared to be in conformity with an IEC Publication.
- 6) All users should ensure that they have the latest edition of this publication.
- 7) No liability shall attach to IEC or its directors, employees, servants or agents including individual experts and members of its technical committees and IEC National Committees for any personal injury, property damage or other damage of any nature whatsoever, whether direct or indirect, or for costs (including legal fees) and expenses arising out of the publication, use of, or reliance upon, this IEC Publication or any other IEC Publications.
- 8) Attention is drawn to the Normative references cited in this publication. Use of the referenced publications is indispensable for the correct application of this publication.

The International Electrotechnical Commission (IEC) draws attention to the fact that it is claimed that compliance with this document may involve the use of patents concerning the functional safety communication profiles for family 6 as follows, where the [xx] notation indicates the holder of the patent right:

DE 103 25 263 A1	[PxC]	Sicherstellung von maximalen Reaktionszeiten in komplexen oder verteilten sicheren und/oder nicht sicheren Systemen
DE 103 18 068 A1	[PxC]	Verfahren und Vorrichtung zum Paket-orientierten Übertragen sicherheitsrelevanter Daten

IEC takes no position concerning the evidence, validity and scope of these patent rights.

The holders of these patents rights have assured the IEC that they are willing to negotiate licences under reasonable and non-discriminatory terms and conditions with applicants throughout the world. In this respect, the statement of the holders of these patent rights are registered with IEC.

Information may be obtained from:

[PxC] Phoenix Contact GmbH & Co. KG
Intellectual Property Licenses &
Standards
Flachsmarktstr. 8
D-32825 Blomberg,
Germany

Attention is drawn to the possibility that some of the elements of this document may be the subject of patent rights other than those identified above. IEC shall not be held responsible for identifying any or all such patent rights.

International Standard IEC 61784-3-6 has been prepared by subcommittee 65C: Industrial networks, of IEC technical committee 65: Industrial process measurement, control and automation.

This bilingual version (2013-07) corresponds to the monolingual English version, published in 2007-12.

The text of this standard is based on the following documents:

FDIS	Report on voting
65C/470/FDIS	65C/481/RVD

Full information on the voting for the approval of this standard can be found in the report on voting indicated in the above table.

The French version of this standard has not been voted upon.

This publication has been drafted in accordance with the ISO/IEC Directives, Part 2.

The committee has decided that the contents of this publication will remain unchanged until the maintenance result date indicated on the IEC web site under "<http://webstore.iec.ch>" in the data related to the specific publication. At this date, the publication will be

- reconfirmed,
- withdrawn,
- replaced by a revised edition, or
- amended.

The list of all parts of the IEC 61784-3 series, under the general title *Industrial communication networks – Profiles – Functional safety fieldbuses*, can be found on the IEC website.

IMPORTANT – The 'colour inside' logo on the cover page of this publication indicates that it contains colours which are considered to be useful for the correct understanding of its contents. Users should therefore print this document using a colour printer.

INTRODUCTION

The IEC 61158 fieldbus standard together with its companion standards IEC 61784-1 and IEC 61784-2 defines a set of communication protocols that enable distributed control of automation applications. Fieldbus technology is now considered well accepted and well proven. Thus many fieldbus enhancements are emerging, addressing not yet standardized areas such as real time, safety-related and security-related applications.

This standard explains the relevant principles for functional safety communications with reference to IEC 61508 series and specifies several safety communication layers (profiles and corresponding protocols) based on the communication profiles and protocol layers of IEC 61784-1, IEC 61784-2 and the IEC 61158 series. It does not cover electrical safety and intrinsic safety aspects.

Figure 1 shows the relationships between this standard and relevant safety and fieldbus standards in a machinery environment.

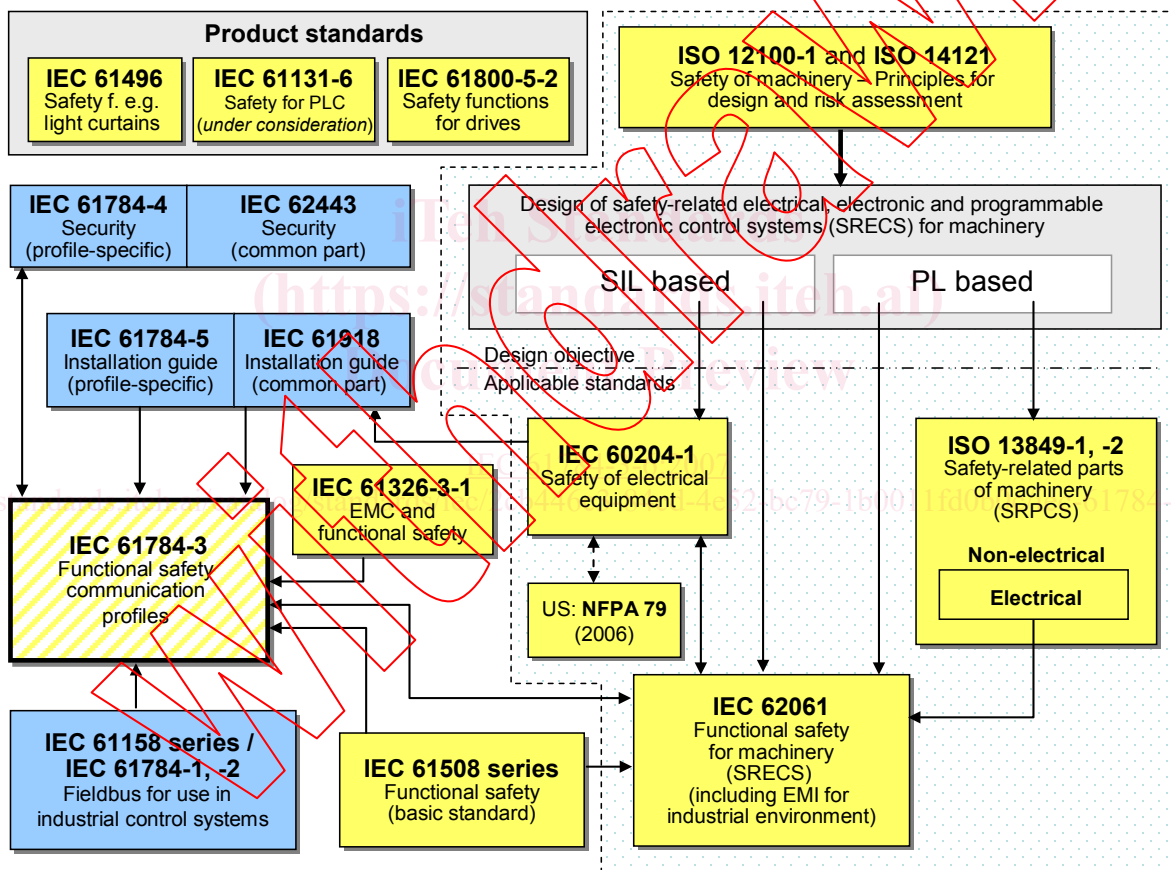

Key

- (yellow) safety-related standards
- (blue) fieldbus-related standards
- (dashed yellow) this standard

Figure 1 – Relationships of IEC 61784-3 with other standards (machinery)

Figure 2 shows the relationships between this standard and relevant safety and fieldbus standards in a process environment.

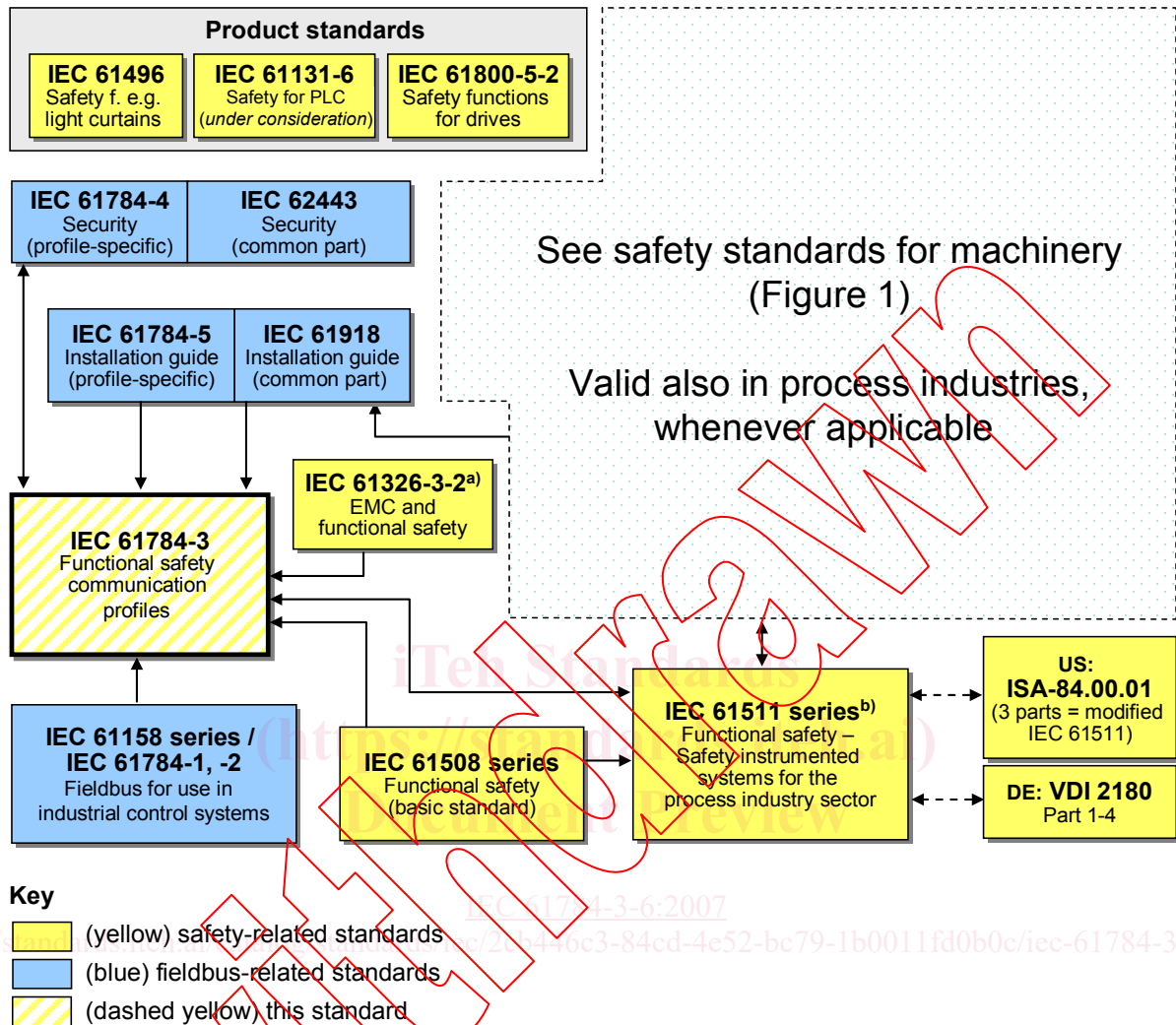

^a For specified electromagnetic environments; otherwise IEC 61326-3-1.

^b EN ratified.

Figure 2 – Relationships of IEC 61784-3 with other standards (process)

Safety communication layers which are implemented as parts of safety-related systems according to IEC 61508 series provide the necessary confidence in the transportation of messages (information) between two or more participants on a fieldbus in a safety-related system, or sufficient confidence of safe behaviour in the event of fieldbus errors or failures.

Safety communication layers specified in this standard do this in such a way that a fieldbus can be used for applications requiring functional safety up to the Safety Integrity Level (SIL) specified by its corresponding functional safety communication profile.

The resulting SIL claim of a system depends on the implementation of the selected functional safety communication profile within this system – implementation of a functional safety communication profile in a standard device is not sufficient to qualify it as a safety device.

This standard describes

- basic principles for implementing the requirements of IEC 61508 series for safety-related data communications, including possible transmission faults, remedial measures and considerations affecting data integrity;
- individual description of functional safety profiles for several communication profile families in IEC 61784-1 and IEC 61784-2;
- safety layer extensions to the communication service and protocols sections of the IEC 61158 series.

Withdrawing

iTech Standards
(<https://standards.itih.ai>)
Document Preview

<https://standards.itih.ai/standards/iec/2eb476c3-84cd-4e52-bc79-1b0011fd0b0c/iec-61784-3-6-2007>

<https://standards.itih.ai/standards/iec/2eb476c3-84cd-4e52-bc79-1b0011fd0b0c/iec-61784-3-6-2007>

INDUSTRIAL COMMUNICATION NETWORKS – PROFILES –

Part 3-6: Functional safety fieldbuses – Additional specifications for CPF 6

1 Scope

This part of the IEC 61784-3 series specifies a safety communication layer (services and protocol) based on CPF 6 of IEC 61784-1, IEC 61784-2 and IEC 61158 Type 8. It identifies the principles for functional safety communications defined in IEC 61784-3 that are relevant for this safety communication layer.

NOTE 1 It does not cover electrical safety and intrinsic safety aspects. Electrical safety relates to hazards such as electrical shock. Intrinsic safety relates to hazards associated with potentially explosive atmospheres.

This part¹ defines mechanisms for the transmission of safety-relevant messages among participants within a distributed network using fieldbus technology in accordance with the requirements of IEC 61508 for functional safety. These mechanisms may be used in various industrial applications such as process control, manufacturing automation and machinery.

This part provides guidelines for both developers and assessors of compliant devices and systems.

NOTE 2 The resulting SIL claim of a system depends on the implementation of the selected functional safety communication profile within this system – implementation of a functional safety communication profile according to this part in a standard device is not sufficient to qualify it as a safety device.

2 Normative references

The following referenced documents are indispensable for the application of this document. For dated references, only the edition cited applies. For undated references, the latest edition of the referenced document (including any amendments) applies.

IEC 61131-3, *Programmable controllers – Part 3: Programming languages*

IEC 61158-2, *Industrial communication networks – Fieldbus specifications – Part 2: Physical layer specification and service definition*

IEC 61158-3-8, *Industrial communication networks – Fieldbus specifications – Part 3-8: Data-link layer service definition*

IEC 61158-4-8, *Industrial communication networks – Fieldbus specifications – Part 4-8: Data-link layer protocol specification*

IEC 61158-5-8, *Industrial communication networks – Fieldbus specifications – Part 5-8: Application layer service definition*

IEC 61158-6-8, *Industrial communication networks – Fieldbus specifications – Part 6-8: Application layer protocol specification*

¹ In the following pages of this standard, “this part” will be used for “this part of the IEC 61784-3 series”.