

INTERNATIONAL
STANDARD

ISO
3271

Third edition
1995-11-01

**Iron ores — Determination of tumble
strength**

iTeh STANDARD PREVIEW
Minerais de fer — Essai au tambour
(standards.iteh.ai)

ISO 3271:1995

<https://standards.iteh.ai/catalog/standards/sist/c63d3e00-e5a7-40f2-89f1-9ec7c50f1339/iso-3271-1995>



Reference number
ISO 3271:1995(E)

Foreword

ISO (the International Organization for Standardization) is a worldwide federation of national standards bodies (ISO member bodies). The work of preparing International Standards is normally carried out through ISO technical committees. Each member body interested in a subject for which a technical committee has been established has the right to be represented on that committee. International organizations, governmental and non-governmental, in liaison with ISO, also take part in the work. ISO collaborates closely with the International Electrotechnical Commission (IEC) on all matters of electrotechnical standardization.

Draft International Standards adopted by the technical committees are circulated to the member bodies for voting. Publication as an International Standard requires approval by at least 75 % of the member bodies casting a vote.

International Standard ISO 3271 was prepared by Technical Committee ISO/TC 102, *Iron ores*, Subcommittee SC 3, *Physical testing*.

This third edition cancels and replaces the second edition (ISO 3271:1985), of which clauses 3, 5, 6, 7 and 8 have been technically revised.

Annex A forms an integral part of this International Standard. Annexes B and C are for information only.

© ISO 1995

All rights reserved. Unless otherwise specified, no part of this publication may be reproduced or utilized in any form or by any means, electronic or mechanical, including photocopying and microfilm, without permission in writing from the publisher.

International Organization for Standardization
Case Postale 56 • CH-1211 Genève 20 • Switzerland

Printed in Switzerland

Introduction

The tumble strength test is one of several procedures used to evaluate the behaviour of iron ores and iron ore agglomerates, such as pellets or sinter, under specific conditions. The conditions involved in this test are:

- a) a sample having a specified size range;
- b) a specified sample mass;
- c) tumbling in a drum having specified dimensions;
- d) sieving to determine tumble indices.

iTeh STANDARD PREVIEW (standards.iteh.ai)

[ISO 3271:1995](https://standards.iteh.ai/catalog/standards/sist/c63d3e00-e5a7-40f2-89f1-9ec7c50f1339/iso-3271-1995)

<https://standards.iteh.ai/catalog/standards/sist/c63d3e00-e5a7-40f2-89f1-9ec7c50f1339/iso-3271-1995>

iTeh STANDARD PREVIEW
This page intentionally left blank
(standards.iteh.ai)

[ISO 3271:1995](#)

<https://standards.iteh.ai/catalog/standards/sist/c63d3e00-e5a7-40f2-89f1-9ec7c50f1339/iso-3271-1995>

Iron ores — Determination of tumble strength

1 Scope

This International Standard specifies a method for evaluating the tumble strength of iron ores (resistance to degradation by impact and abrasion) by determining the tumble index and the abrasion index.

This method is applicable to sized iron ore and to such iron ore agglomerates as pellets or sinter.

2 Normative references

The following standards contain provisions which, through reference in this text, constitute provisions of this International Standard. At the time of publication, the editions indicated were valid. All standards are subject to revision, and parties to agreements based on this International Standard are encouraged to investigate the possibility of applying the most recent editions of the standards indicated below. Members of IEC and ISO maintain registers of currently valid International Standards.

ISO 3310-1:1990, *Test sieves — Technical requirements and testing — Part 1: Test sieves of metal wire cloth*.

ISO 3310-2:1990, *Test sieves — Technical requirements and testing — Part 2: Test sieves of perforated metal plate*.

ISO 4701:1985, *Iron ores — Determination of size distribution by sieving*.

ISO 10836:1994, *Iron ores — Method of sampling and sample preparation for physical testing*.

3 Definitions

For the purposes of this International Standard, the following definitions apply.

3.1 tumble strength: The resistance of lump ore or of agglomerates to size degradation by impact and abrasion, when subjected to a tumble test in a rotating drum.

[ISO 11323]

3.2 tumble index: A relative measure of the tumble strength of lump ore or agglomerates. It is expressed as the mass percentage of + 6,30 mm size fraction in a sample after a tumble test.

3.3 abrasion index: A relative measure of the size degradation of lump ore or agglomerates by abrasion. It is expressed as the mass percentage of – 500 µm size fraction in a sample after a tumble test.

3.4 test sample for the tumble test: The sample taken for the determination of tumble strength of a lot or part of a lot.

4 Principle

Tumbling of a 15 kg test portion by using a circular drum (internal diameter 1 000 mm, internal length 500 mm) at 25 r/min ± 1 r/min for a total of 200 revolutions.

Sieving with test sieves including square apertures of 6,30 mm and 500 µm.

Weighing of the appropriate size fractions and calculation of tumble index and abrasion index.

5 Apparatus

5.1 Tumble test apparatus, as shown in figure 1, consisting of a circular drum of internal diameter 1 000 mm and internal length 500 mm, constructed of steel plate at least 5 mm in thickness. The drum shall be replaced whenever the thickness of the plate is reduced by wear to 3 mm in any area.

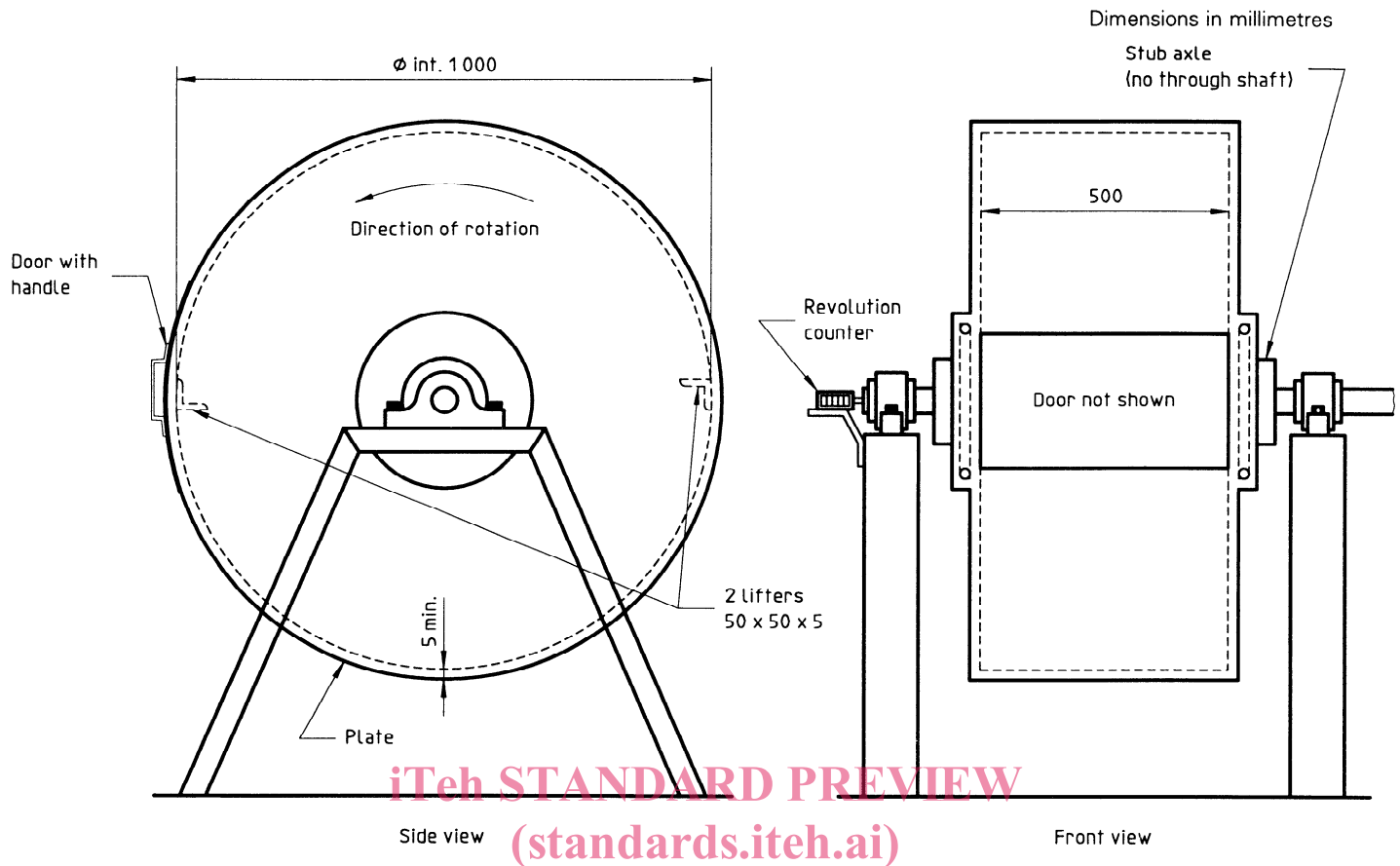

Figure 1 — Example of tumble test apparatus

Two equally spaced steel angle lifters, of section 50 mm × 50 mm × 5 mm, of length 500 mm (i.e. equal to the internal length of the drum) shall be solidly attached longitudinally inside the drum by welding in such a manner as to prevent accumulation of material between lifter and drum. One of the lifters shall be attached to the door for ease of sample removal. The other shall be positioned 180° from the first. Each lifter shall be fastened so that it points towards the axis of the drum, with its attached leg pointing away from the direction of rotation, thus providing a clear unobstructed shelf for lifting the sample. The lifters shall be replaced in any case when the width of the shelf is reduced by wear to less than 47 mm.

The door shall be so constructed as to fit into the drum to form a smooth inner surface. During the test it shall be capable of being rigidly fastened and sealed to prevent loss of the sample.

The drum shall be rotated on stub axles attached to its ends by means of flanges welded so as to provide smooth inner surfaces.

The apparatus shall be fitted with a revolution counter and with an automatic device for stopping the drum

after a predetermined number of revolutions. The apparatus shall operate on a power supply of a minimum of 1,5 kW to ensure that the drum attains full speed in one revolution, rotates uniformly and stops within one revolution.

5.2 Test sieves, having square apertures of the following nominal sizes and conforming to ISO 3310-1 or ISO 3310-2.

40,0 mm; 25,0 mm; 16,0 mm; 10,0 mm; 6,30 mm; 500 μ m.

5.3 Weighing devices, having appropriate capacities, each having a sensitivity of 1/1 000 or better.

6 Preparation of test samples

6.1 General

The samples for tumble testing shall be prepared according to ISO 10836. The tumble and abrasion indices are influenced by the amount of handling to which the material is subjected. The sampling point shall be reported with the test results.

The sample for tumble test shall be dried at $105\text{ °C} \pm 5\text{ °C}$ for at least 12 h and then allowed to cool to room temperature. From the dried sample, test portions as specified in table 1 shall be prepared.

6.2 Pellets

The sample for tumble testing shall be sufficient to provide at least 60 kg of pellets that will pass a 40,0 mm sieve and be retained on a 6,30 mm sieve. From this sample, at least four test portions shall be prepared.

6.3 Sinters and sized iron ores

The sample for tumble testing shall be sufficient to provide at least 60 kg of sinter or sized iron ore that will pass a 40,0 mm sieve and be retained on a 10,0 mm sieve. This sample shall be separated into four fractions by sieving through 25,0 mm, 16,0 mm and 10,0 mm sieves. From the material on the three sieves, at least four test portions shall be reconstituted by taking a proportionate mass of material from each of the three fractions. The mass of the individual fractions shall be recorded.

7 Procedure¹⁾

7.1 Number of determinations

Carry out the test in duplicate.

7.2 Test portion

Use a test portion of $15\text{ kg} \pm 0,15\text{ kg}$, prepared according to clause 6.

7.3 Tumbling

Place the test portion carefully in the tumble drum. Tightly fasten the door and rotate the drum at $25\text{ r/min} \pm 1\text{ r/min}$ for a total of 200 revolutions.

NOTE 1 It is recommended that after tumbling, the tumble drum should be kept at rest for at least 2 min.

Remove all the material from the drum.

7.4 Sieving

Sieving shall be carried out in accordance with ISO 4701. Place the material on a nest of four sieves which shall include a 6,30 mm and 500 μm sieve and shake for 1 min by hand. Determine and record the mass of the + 6,30 mm fraction, – 6,30 mm + 500 μm fraction and – 500 μm fraction.

NOTES

2 Mechanical sieving may be used provided that preliminary tests give results similar to those obtained by hand sieving, within the permissible tolerance of 2 % absolute.

3 It is considered that the set of sieves used for sieving after tumbling should include a sieve of suitable aperture size between 6,30 mm and 500 μm (for e.g. 2,00 mm or 1,00 mm) in order to improve the efficiency of the 500 μm sieve by decreasing the sample mass retained on it. It could also be claimed to be advantageous for works control and ease of sieving to include an aperture size above 6,30 mm, e.g. either 10,0 mm or 8,00 mm.

4 Care should be taken to ensure the sieves are not overloaded and the recommendations of ISO 4701:1985, annex A, should be observed.

7.5 Permissible loss of mass

The difference between the initial mass of the test portion and the total mass of the fractions shall not exceed 1,0 % of the initial mass of the test portion. If this difference exceeds 1,0 % the test shall be rejected.

Table 1 — Test portion for the tumble test

Sample	Size range of test portion mm	Mass of test portion kg	Number of test portions
Iron ore pellets	– 40,0 + 6,30	15 \pm 0,15	at least 4
Sinters, sized iron ores	– 40,0 + 10,0		

1) A schematic representation of the procedure is given in annex B.

8 Expression of results

8.1 Calculation of the tumble and abrasion indices

The tumble index (TI) and the abrasion index (AI), expressed as percentages by mass, are calculated from the following formulae:

$$TI = \frac{m_1}{m_0} \times 100$$

$$AI = \frac{m_0 - (m_1 + m_2)}{m_0} \times 100$$

where

m_0 is the mass of the test portion, in kilograms, as weighed out and placed in the tumble drum;

m_1 is the mass of + 6,30 mm fraction of the tumbled test portion, in kilograms;

m_2 is the mass of – 6,30 mm + 500 μm fraction of the tumbled test portion, in kilograms.

Express each index to one decimal place.

8.2 Repeatability and acceptance of test results

The difference between the results of duplicate tests (in the same laboratory using the same apparatus) shall not differ by more than the value given in table 2²⁾.

If the difference between the results of the duplicate tests does not exceed the repeatability given in table 2, the mean value shall be reported to one decimal place.

If the difference between the results of duplicate tests exceeds the repeatability given in table 2, further duplicate test(s) shall be carried out in accordance with the flowsheet presented in annex A.

Table 2 — Repeatability

Tumble strength	Repeatability (relating to 95 % probability)
Tumble index TI (+ 6,30 mm)	$r_{TI} = 1,4$ % absolute
Abrasion index AI (– 500 μm)	$r_{AI} = 0,8$ % absolute

9 Test report

The test report shall include the following information:

- reference to this International Standard;
- details necessary for the identification of the sample and sampling point position;
- results of the test;
- reference number of the report;
- any characteristics noticed during the test and any operations which may have had an influence on the results, e.g. scalping sieves used, method of sieving, loss of mass during the test.

2) Derived from the results of the international test which are reported in the document ISO/TC 102/SC 3 N 487E.

Annex A (normative)

Flowsheet of the procedure for the acceptance of test results

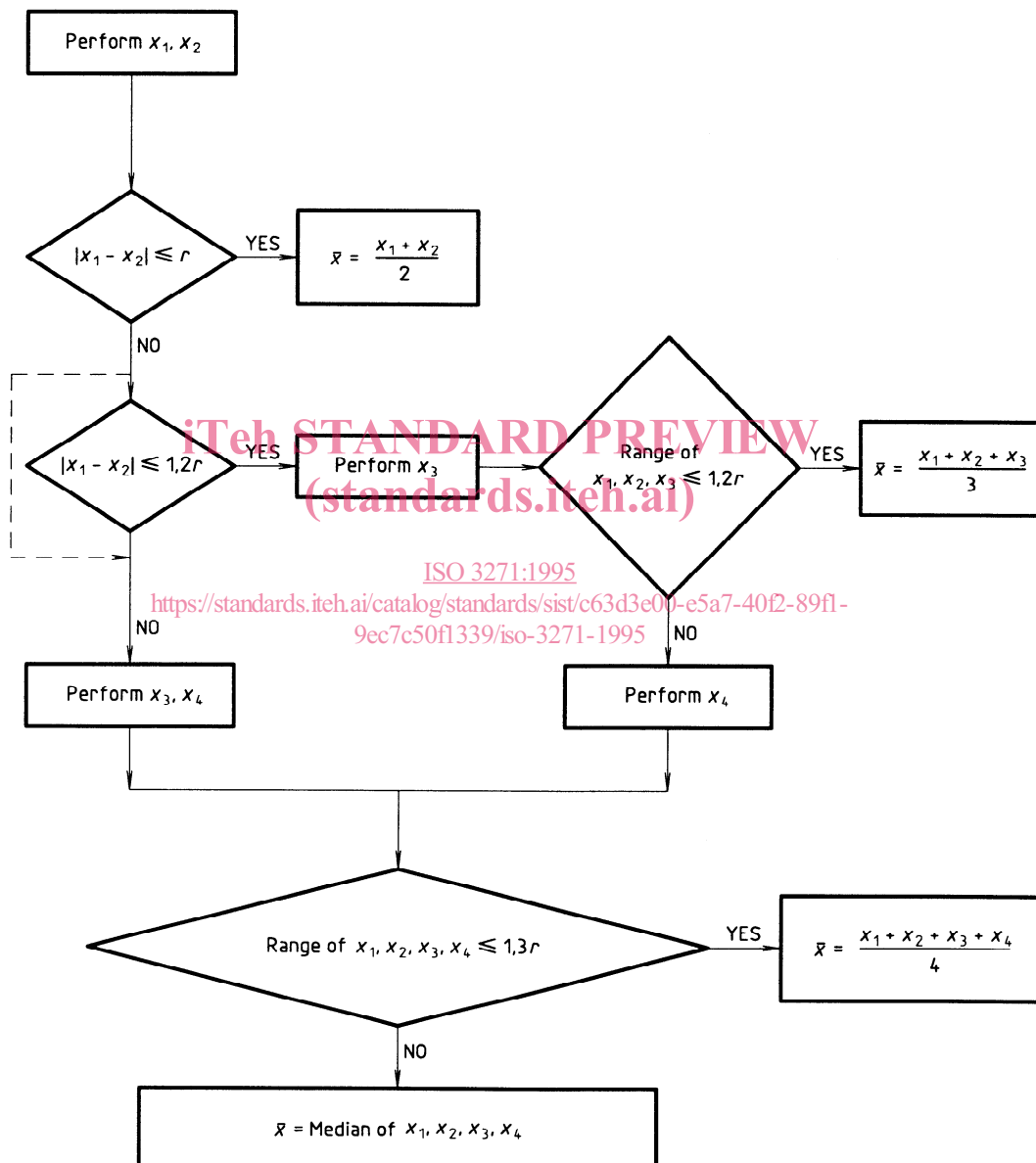

where r is as defined in table 2.