



SLOVENSKI STANDARD

SIST EN 60728-1:2008

01-julij-2008

BUXca Yý U

SIST EN 50083-7:1999

SIST EN 50083-7:1999/A1:2001

Kabelska omrežja za televizijske in zvokovne signale ter interaktivne storitve - 1. del: Lastnosti sistema za naprejšnje poti (IEC 60728-1:2007)

Cable networks for television signals, sound signals and interactive services - Part 1: System performance of forward paths (IEC 60728-1:2007)

iTeh STANDARD PREVIEW

Kabelnetze für Fernsehsignale, Tonsignale und interaktive Dienste - Teil 1: Systemanforderungen in Vorwärtsrichtung (IEC 60728-1:2007)

[SIST EN 60728-1:2008](https://standards.iTeh.ai/catalog/standards/sist/d46719-41c0-496d-b82b-5081328de2f/sist-en-60728-1-2008)

Réseaux de distribution par câbles pour signaux de télévision, signaux de radiodiffusion sonore et services interactifs - Partie 1: Performance de la voie directe (CEI 60728-1:2007)

Ta slovenski standard je istoveten z: EN 60728-1:2008

ICS:

33.060.40 Kabelski razdelilni sistemi Cabled distribution systems

SIST EN 60728-1:2008

en

iTeh STANDARD PREVIEW
(standards.iteh.ai)

SIST EN 60728-1:2008

<https://standards.iteh.ai/catalog/standards/sist/da46319c-41c0-496d-b82b-50fa328dc2f/sist-en-60728-1-2008>

English version

**Cable networks for television signals,
sound signals and interactive services -
Part 1: System performance of forward paths
(IEC 60728-1:2007)**

Réseaux de distribution par câbles
pour signaux de télévision,
signaux de radiodiffusion sonore
et services interactifs -
Partie 1: Performance de la voie directe
(CEI 60728-1:2007)

Kabelnetze für Fernsehsignale,
Tonsignale und interaktive Dienste -
Teil 1: Systemanforderungen
in Vorwärtsrichtung
(IEC 60728-1:2007)

**iTeh STANDARD PREVIEW
(standards.iteh.ai)**

This European Standard was approved by CENELEC on 2008-04-01. CENELEC members are bound to comply with the CEN/CENELEC Internal Regulations which stipulate the conditions for giving this European Standard the status of a national standard without any alteration.

Up-to-date lists and bibliographical references concerning such national standards may be obtained on application to the Central Secretariat or to any CENELEC member.

This European Standard exists in two official versions (English and German). A version in any other language made by translation under the responsibility of a CENELEC member into its own language and notified to the Central Secretariat has the same status as the official versions.

CENELEC members are the national electrotechnical committees of Austria, Belgium, Bulgaria, Cyprus, the Czech Republic, Denmark, Estonia, Finland, France, Germany, Greece, Hungary, Iceland, Ireland, Italy, Latvia, Lithuania, Luxembourg, Malta, the Netherlands, Norway, Poland, Portugal, Romania, Slovakia, Slovenia, Spain, Sweden, Switzerland and the United Kingdom.

CENELEC

European Committee for Electrotechnical Standardization
Comité Européen de Normalisation Electrotechnique
Europäisches Komitee für Elektrotechnische Normung

Central Secretariat: rue de Stassart 35, B - 1050 Brussels

Foreword

The text of document 100/1242/FDIS, future edition 4 of IEC 60728-1, prepared by technical area 5, Cable networks for television signals, sound signals and interactive services, of IEC TC 100, Audio, video and multimedia systems and equipment, was submitted to the IEC-CENELEC parallel vote and was approved by CENELEC as EN 60728-1 on 2008-04-01.

This European Standard supersedes EN 50083-7:1996 + A1:2000 + corrigendum August 2007.

The following dates were fixed:

- latest date by which the EN has to be implemented at national level by publication of an identical national standard or by endorsement (dop) 2009-01-01
- latest date by which the national standards conflicting with the EN have to be withdrawn (dow) 2011-04-01

For this European Standard the informative Annex J of IEC 60728-1:2007 shall be disregarded and has been replaced by the informative Annex ZB, *A-deviations*.

Annexes ZA and ZB have been added by CENELEC.

Endorsement notice

The text of the International Standard IEC 60728-1:2007 was approved by CENELEC as a European Standard without any modification. (standards.iteh.ai)

In the official version, for Bibliography, the following notes have to be added for the standards indicated:

	<u>SIST EN 60728-1:2008</u>
IEC 61169-2	https://standards.iteh.ai/catalog/standards/sist/da46319c-41c0-496d-b82b-30a1b28dc21/sist-en-60728-1-2008 NOTE Harmonized as EN 61169-2:2007 (not modified).
IEC 61169-24	NOTE Harmonized as EN 61169-24:2001 (not modified).
CISPR 16-1	NOTE Harmonized in EN 55016-1 series (not modified).

Annex ZA
(normative)

**Normative references to international publications
with their corresponding European publications**

The following referenced documents are indispensable for the application of this document. For dated references, only the edition cited applies. For undated references, the latest edition of the referenced document (including any amendments) applies.

NOTE 1 When an international publication has been modified by common modifications, indicated by (mod), the relevant EN/HD applies.

NOTE 2 Where a standard cited below belongs to the EN 50000 series, the European Standard applies instead of the relevant International Standard.

<u>Publication</u>	<u>Year</u>	<u>Title</u>	<u>EN/HD</u>	<u>Year</u>
-	-	Coaxial cables - Part 2-4: Sectional specification for cables used in cabled distribution networks - Indoor drop cables for systems operating at 5 MHz - 3 000 MHz	EN 50117-2-4	- ¹⁾
-	-	Characteristics of DAB receivers	EN 50248	- ¹⁾
-	-	Digital Video Broadcasting (DVB): Framing structure, channel coding and modulation for 11/12 GHz satellite services	ETSI EN 300 421	- ¹⁾
-	-	Digital Video Broadcasting (DVB): Framing structure, channel coding and modulation for cable systems	ETSI EN 300 429	- ¹⁾
-	-	Digital Video Broadcasting (DVB): Specification for Service Information (SI) in DVB systems	ETSI EN 300 468	- ¹⁾
-	-	Digital Video Broadcasting (DVB): Satellite Master Antenna Television (SMATV) distribution systems	ETSI EN 300 473	- ¹⁾
-	-	Digital Video Broadcasting (DVB): Framing structure, channel coding and modulation for digital terrestrial television	ETSI EN 300 744	- ¹⁾
-	-	Digital Video Broadcasting (DVB): Multipoint Video Distribution Systems (MVDS) at 10 GHz and above	ETSI EN 300 748	- ¹⁾
-	-	Digital Video Broadcasting (DVB): Microwave Multipoint Distribution Systems (MMDS) below 10 GHz	ETSI EN 300 749	- ¹⁾
-	-	Digital Video Broadcasting (DVB); Second generation framing structure, channel coding and modulation systems for Broadcasting, Interactive Services, News Gathering and other broadband satellite applications	ETSI EN 302 307	- ¹⁾

¹⁾ Undated reference.

<u>Publication</u>	<u>Year</u>	<u>Title</u>	<u>EN/HD</u>	<u>Year</u>
-	-	Satellite Earth Stations and Systems (SES);Television Receive-Only (TVRO) satellite earth stations operating in the 11/12 GHz frequency bands	ETSI ETS 300 784	- ¹⁾
-	-	Digital Video Broadcasting (DVB);Guidelines on implementation and usage of Service Information (SI)	ETSI TR 101 211	- ¹⁾
-	-	Digital Video Broadcasting (DVB);Measurement guidelines for DVB systems	ETSI TR 101 290	- ¹⁾
IEC 60050-705	- ¹⁾	International Electrotechnical Vocabulary (IEV) - Chapter 705: Radio wave propagation	-	-
IEC 60050-712	- ¹⁾	International Electrotechnical Vocabulary (IEV) - Chapter 712: Antennas	-	-
IEC 60050-713	- ¹⁾	International Electrotechnical Vocabulary (IEV) - Part 713: Radiocommunications: transmitters, receivers, networks and operation	-	-
IEC 60050-725	- ¹⁾	International Electrotechnical Vocabulary (IEV) - Chapter 725: Space radiocommunications	-	-
IEC 60617	Data-base	Graphical symbols for diagrams	-	-
IEC 60728-2	- ¹⁾	Cabled distribution systems for television and sound signals - Part 2: Electromagnetic compatibility for equipment	EN 50083-2	2006 ²⁾
IEC 60728-3	- ¹⁾	Cable networks for television signals, sound signals and interactive services - Part 3: Active wideband equipment for coaxial cable networks	EN 60728-3	2006 ²⁾
IEC 60728-5	- ¹⁾	Cable networks for television signals, sound signals and interactive services - Part 5: Headend equipment	EN 60728-5	2008 ²⁾
IEC 60728-10	- ¹⁾	Cable networks for television signals, sound signals and interactive services - Part 10: System performance of return paths	EN 60728-10	2006 ²⁾
IEC 60728-11 (mod)- ¹⁾	- ¹⁾	Cable networks for television signals, sound signals and interactive services - Part 11: Safety	EN 60728-11	2005 ²⁾
IEC 60728-12	- ¹⁾	Cabled distribution systems for television and sound signals - Part 12: Electromagnetic compatibility of systems	EN 50083-8	2002 ²⁾

²⁾ Valid edition at date of issue.

<u>Publication</u>	<u>Year</u>	<u>Title</u>	<u>EN/HD</u>	<u>Year</u>
IEC 60966-2-4	- ¹⁾	Radio frequency and coaxial cable assemblies - Part 2-4: Detail specification for cable assemblies for radio and TV receivers - Frequency range 0 to 3 000 MHz, IEC 61169-2 connectors	EN 60966-2-4	2003 ²⁾
IEC 60966-2-5	- ¹⁾	Radio frequency and coaxial cable assemblies - Part 2-5: Detail specification for cable assemblies for radio and TV receivers - Frequency range 0 to 1 000 MHz, IEC 61169-2 connectors	EN 60966-2-5	2003 ²⁾
IEC 60966-2-6	- ¹⁾	Radio frequency and coaxial cable assemblies - Part 2-6: Detail specification for cable assemblies for radio and TV receivers - Frequency range 0 to 3 000 MHz, IEC 61169-24 connectors	EN 60966-2-6	2003 ²⁾
ISO/IEC 13818-1	- ¹⁾	Information technology - Generic coding of moving pictures and associated audio information: Systems	-	-
ISO/IEC 13818-2	- ¹⁾	Information technology - Generic coding of moving pictures and associated audio information - Part 2: Video	-	-
ISO/IEC 13818-3	- ¹⁾	Information technology - Generic coding of moving pictures and associated audio information - Part 3: Audio	-	-
ISO/IEC 13818-4	- ¹⁾	Information technology - Generic coding of moving pictures and associated audio information - Part 4: Conformance testing	-	-
ISO/IEC 14496-1	- ¹⁾	Information technology - Coding of audio-visual objects - Part 1: Systems	-	-
ISO/IEC 14496-2	- ¹⁾	Information technology - Coding of audio-visual objects - Part 2: Visual	-	-
ISO/IEC 14496-3	- ¹⁾	Information technology - Coding of audio-visual objects - Part 3: Audio	-	-
ISO/IEC 14496-4	- ¹⁾	Information technology - Coding of audio-visual objects - Part 4: Conformance testing	-	-
ITU-R Recommendation BS.412-9	- ¹⁾	Planning standards for terrestrial FM sound broadcasting at VHF	-	-
ITU-R Recommendation BT.417-4	- ¹⁾	Minimum field strengths for which protection may be sought in planning an analogue terrestrial television service	-	-



 (standardsite.co.uk)

 SIST EN 60728-1:2008

<https://standards.ieh.ai/catalog/standards/sist/da46319c-41c0-496d-b82b-301120070000/en-60728-1-2008>

<u>Publication</u>	<u>Year</u>	<u>Title</u>	<u>EN/HD</u>	<u>Year</u>
ITU-R Recommendation BT.470-7	- ¹⁾	Conventional analogue television systems	-	-
ITU-R Recommendation BT.500-11	- ¹⁾	Methodology for the subjective assessment of the quality of television pictures	-	-
ITU-T Recommendation J.61	- ¹⁾	Transmission performance of television circuits designed for use in international connections	-	-
ITU-T Recommendation J.63	- ¹⁾	Insertion of test signals in the field-blanking interval of monochrome and colour television signals	-	-

iTeh STANDARD PREVIEW (standards.iteh.ai)

SIST EN 60728-1:2008

<https://standards.iteh.ai/catalog/standards/sist/da46319c-41c0-496d-b82b-50fa328dc2f/sist-en-60728-1-2008>

Annex ZB
(informative)

A-deviations

A-deviation: National deviation due to regulations, the alteration of which is for the time being outside the competence of the CENELEC national member.

This European Standard does not fall under any Directive of the EC.

In the relevant CENELEC countries these A-deviations are valid instead of the provisions of the European Standard until they have been removed.

Clause Deviation

3.1.52 Norway

(Regulations on Electronic Communications Networks and Services (Ecom Regulations) laid down by the Norwegian Ministry of Transport and Communications on 16 February 2004)

When installing coaxial cable-based networks, the part of the network to which the end-user is connected shall be placed in a star structure. It is not permitted to insert receiver connections into the connection between the star points.

5.4.1 Netherlands

(Dutch Technical Regulations for CATV networks (Technische Voorschriften voor Centrale Antenne Inrichtingen, 3e uitgave), 21 December 1977, which are valid for CATV networks in accordance with Article 21 of the Dutch Telecommunications law (Stb. 1988, 520))

Replace by/add the following "minimum and maximum carrier levels" regulation:

FM sound mono: SIST EN 60728-1:2008	80 dB(μV)max
--	--------------

(measured in accordance with CISPR 16-1 [4] (quasi-peak measurement within 120 kHz bandwidth))

5.6.2 Netherlands

(Dutch Technical Regulations for CATV networks (Technische Voorschriften voor Centrale Antenne Inrichtingen, 3e uitgave), 21 December 1977, which are valid for CATV networks in accordance with Article 21 of the Dutch Telecommunications law (Stb. 1988, 520))

Add the group delay response curve valid for PAL with FM-FM sound (see Annex ZB, 5.4.1).

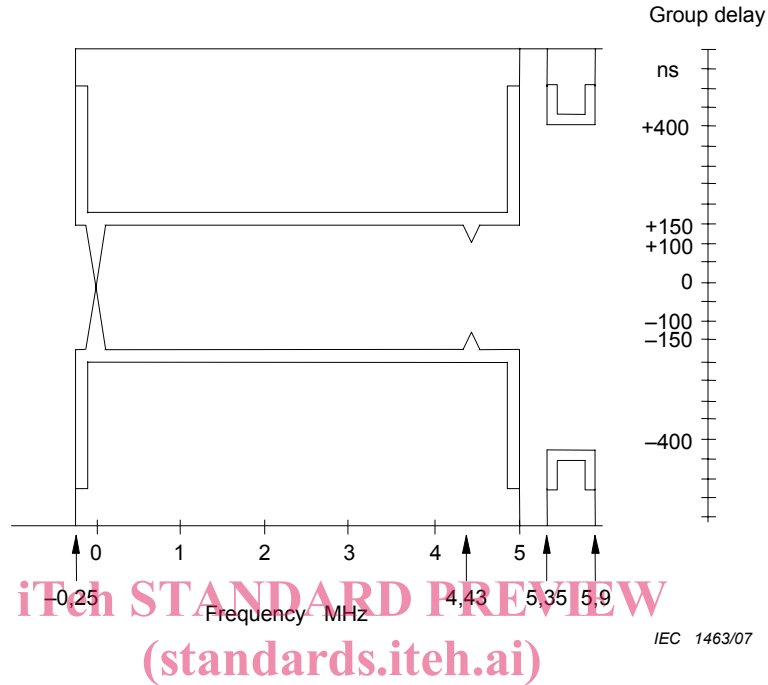

Figure ZB.1 – Mask group delay characteristic for PAL signals with FM-FM sound

<https://standards.iteh.ai/catalog/standards/sist/da46319c-41c0-496d-b82b-50faB28dc2f/sist-en-60728-1-2008>

5.9.1 Netherlands

(Dutch Technical Regulations for CATV networks (Technische Voorschriften voor Centrale Antenne Inrichtingen, 3e uitgave), 21 December 1977, which are valid for CATV networks in accordance with Article 21 of the Dutch Telecommunications law (Stb. 1988, 520))

Replace by/add the following “single-frequency interference” regulation:

AM-VSB-PAL-signals:	$C/I \geq 60$ dB	(measured in a bandwidth of 300 kHz)
For signals outside used TV channels:	$C/I \geq 40$ dB	

5.10.2 Netherlands

(Dutch Technical Regulations for CATV networks (Technische Voorschriften voor Centrale Antenne Inrichtingen, 3e uitgave), 21 December 1977, which are valid for CATV networks in accordance with Article 21 of the Dutch Telecommunications law (Stb. 1988, 520))

Replace the requirements for “echoes in television channels, PAL-SECAM standards” by the “requirement for echo loss in relation to the time delay of the reflected signal for AM-PAL-TV and FM-radio” (Figure ZB.2).

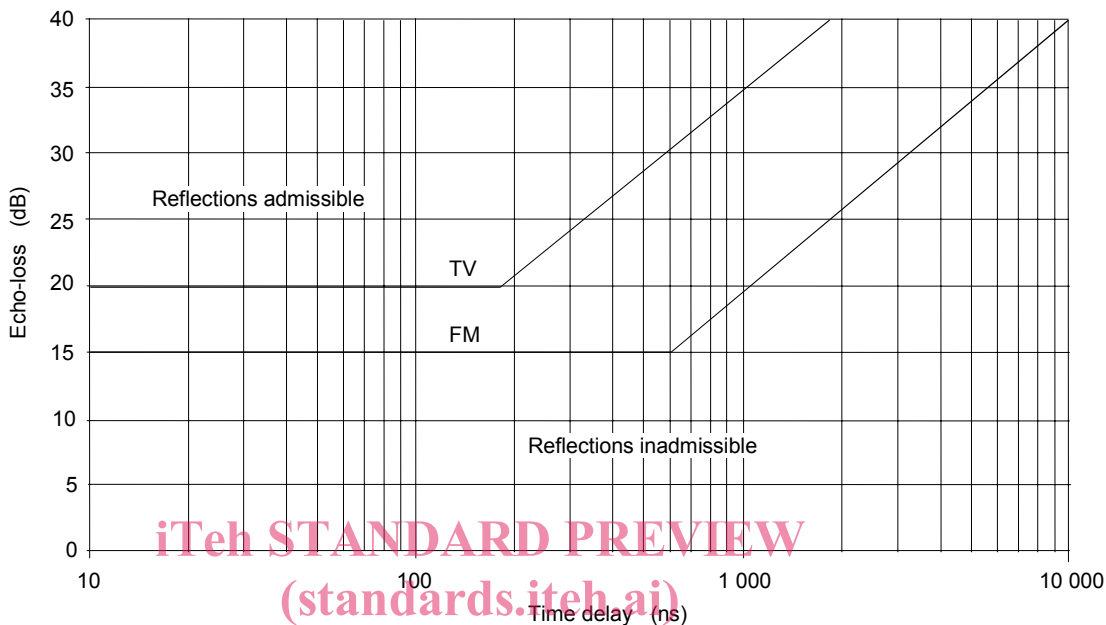

IEC 1468

SIST EN 60728-1:2008

[https://standards.iteh.ai/catalog/standards/sist/da46319c-41c0-496d-b82b-](https://standards.iteh.ai/catalog/standards/sist/da46319c-41c0-496d-b82b-506af378dc2f/sist-en-60728-1-2008)

[506af378dc2f/sist-en-60728-1-2008](https://standards.iteh.ai/catalog/standards/sist/da46319c-41c0-496d-b82b-506af378dc2f/sist-en-60728-1-2008)

Figure ZB.2 – Requirement for echo loss in relation to the time delay of the reflected signal

5.12.1 Denmark

(Danish technical regulations for CATV-networks, which are applicable to those networks in accordance with national legislation act. nr; 277 of June 1995, given by the Ministry of Research)

Add the requirement for “decoding margin” being “the decoding margin must be 40 %, when the margin is a minimum of 70 % at the receiving antenna”.

5.14.3 Netherlands

(Dutch Technical Regulations for CATV networks (Technische Voorschriften voor Centrale Antenne Inrichtingen, 3e uitgave), 21 December 1977, which are valid for CATV networks in accordance with Article 21 of the Dutch Telecommunications law (Stb. 1988, 520))

Add the requirement for “adjacent channel spacing” by ≥ 400 kHz.

iTeh STANDARD PREVIEW
(standards.iteh.ai)

SIST EN 60728-1:2008

<https://standards.iteh.ai/catalog/standards/sist/da46319c-41c0-496d-b82b-50fa328dc2f/sist-en-60728-1-2008>

INTERNATIONAL STANDARD

**Cable networks for television signals, sound signals and interactive services –
Part 1: System performance of forward paths**

ITih STANDARD PREVIEW
(standards.iteh.ai)
SIST EN 60728-1:2008
<https://standards.iteh.ai/catalog/standards/sist/da46319c-41c0-496d-b82b-50fa328dc2f/sist-en-60728-1-2008>

INTERNATIONAL
ELECTROTECHNICAL
COMMISSION

PRICE CODE **XG**

CONTENTS

FOREWORD.....	9
INTRODUCTION.....	11
1 Scope.....	16
2 Normative references	17
3 Terms, definitions, symbols and abbreviations.....	19
3.1 Terms and definitions	19
3.2 Symbols	29
3.3 Abbreviations	30
4 Methods of measurement at system outlet.....	32
4.1 General.....	32
4.2 Mutual isolation between system outlets.....	34
4.2.1 Introduction	34
4.2.2 Equipment required	34
4.2.3 Connection of the equipment	34
4.2.4 Measurement procedure.....	35
4.2.5 Presentation of the results.....	36
4.3 Amplitude response within a channel.....	36
4.3.1 Introduction	36
4.3.2 Equipment required	36
4.3.3 Connection of the equipment	36
4.3.4 Measurement procedure.....	37
4.3.5 Presentation of the results.....	39
4.4 Chrominance-luminance gain and delay inequalities.....	39
4.4.1 Introduction	39
4.4.2 Equipment required	40
4.4.3 Connection of the equipment	40
4.4.4 Measurement procedure.....	40
4.4.5 Presentation of the results.....	42
4.5 Non-linear distortion	42
4.5.1 General	42
4.5.2 Intermodulation.....	42
4.5.3 Composite beat	42
4.5.4 Composite crossmodulation.....	47
4.5.5 Intermodulation noise	47
4.5.6 Hum modulation of carriers.....	47
4.5.7 Differential gain and phase.....	52
4.6 Carrier-to-noise ratio	56
4.6.1 Introduction	56
4.6.2 Equipment required	56
4.6.3 Connection of the equipment	56
4.6.4 Measurement set-up.....	57
4.6.5 Measurement procedure.....	57
4.6.6 Presentation of the results.....	58
4.7 Echoes.....	58
4.7.1 Introduction	58

4.7.2	Equipment required	59
4.7.3	Connection of the equipment	60
4.7.4	Measurement procedure	60
4.7.5	Presentation of the results	60
4.8	AM-VSB television, FM radio and FM television signal level	60
4.8.1	General	60
4.8.2	Definitions for NTSC, PAL and SECAM systems	61
4.8.3	Equipment required	61
4.8.4	Measurement procedure	61
4.8.5	Presentation of the results	62
4.9	Data echo rating and data delay inequality	62
4.10	Interference in FM sound radio channels	62
4.11	Methods of measurement for digitally modulated signals	62
4.11.1	Introduction	62
4.11.2	Basic assumptions and measurement interfaces	62
4.11.3	Signal level for digitally modulated signals	65
4.11.4	RF signal-to-noise ratio $S_{D,RF}/N$ for digitally modulated signals	66
4.11.5	Bit error ratio (BER)	68
4.11.6	BER versus E_b/N_0 or C/N	69
4.11.7	Noise margin	72
4.11.8	Modulation error ratio (MER)	74
4.11.9	Phase jitter	76
4.11.10	Phase noise of an RF carrier	78
5	Performance requirements at system outlet	81
5.1	General	81
5.2	Impedance	82
5.3	Requirements at the terminal input	82
5.3.1	Signal level	82
5.3.2	Other parameters	83
5.4	Carrier levels at system outlets	83
5.4.1	Minimum and maximum carrier levels	83
5.4.2	Carrier level differences	84
5.5	Mutual isolation between system outlets	85
5.5.1	Isolation between two subscribers	85
5.5.2	Isolation between individual outlets in one household	85
5.5.3	Isolation between forward and return path	85
5.6	Frequency response within a television channel at any system outlet	86
5.6.1	Amplitude response	86
5.6.2	Group delay	86
5.7	Long-term frequency stability of distributed carrier signals at any system outlet	87
5.8	Random noise	88
5.9	Interference to television channels	89
5.9.1	Single-frequency interference	89
5.9.2	Single-channel intermodulation interference	90
5.9.3	Multiple frequency intermodulation interference	90
5.9.4	Intermodulation noise	90
5.9.5	Cross-modulation	91
5.10	Video baseband requirements	91