

INTERNATIONAL
STANDARD

ISO
9022-8

First edition
1994-07-15

**Optics and optical instruments —
Environmental test methods —**

Part 8:

High pressure, low pressure, immersion

(standards.iteh.ai)

*Optique et instruments d'optique — Méthodes d'essais
d'environnement*
<https://standards.iteh.ai/catalog/standards/sist/e121f9df-192b-41d2-b919-84702261224>
Partie 8: Haute pression, basse pression, immersion



Reference number
ISO 9022-8:1994(E)

Foreword

ISO (the International Organization for Standardization) is a worldwide federation of national standards bodies (ISO member bodies). The work of preparing International Standards is normally carried out through ISO technical committees. Each member body interested in a subject for which a technical committee has been established has the right to be represented on that committee. International organizations, governmental and non-governmental, in liaison with ISO, also take part in the work. ISO collaborates closely with the International Electrotechnical Commission (IEC) on all matters of electrotechnical standardization.

Draft International Standards adopted by the technical committees are circulated to the member bodies for voting. Publication as an International Standard requires approval by at least 75 % of the member bodies casting a vote.

International Standard ISO 9022-8 was prepared by Technical Committee ISO/TC 172, *Optics and optical instruments*, Subcommittee SC 1, *Fundamental standards*.

ISO 9022-8:1994

ISO 9022 consists of the following parts, under the general title *Optics and optical instruments — Environmental test methods*:

- Part 1: *Definitions, extent of testing*
- Part 2: *Cold, heat, humidity*
- Part 3: *Mechanical stress*
- Part 4: *Salt mist*
- Part 5: *Combined cold, low air pressure*
- Part 6: *Dust*
- Part 7: *Drip, rain*
- Part 8: *High pressure, low pressure, immersion*
- Part 9: *Solar radiation*
- Part 10: *Combined sinusoidal vibration, dry heat or cold*

© ISO 1994

All rights reserved. Unless otherwise specified, no part of this publication may be reproduced or utilized in any form or by any means, electronic or mechanical, including photocopying and microfilm, without permission in writing from the publisher.

International Organization for Standardization
Case Postale 56 • CH-1211 Genève 20 • Switzerland

Printed in Switzerland

- *Part 11: Mould growth*
- *Part 12: Contamination*
- *Part 13: Combined shock, bump or free fall, dry heat or cold*
- *Part 14: Dew, hoarfrost, ice*
- *Part 15: Combined random vibration wide band: reproducibility medium, in dry heat or cold*
- *Part 16: Combined bounce or steady-state acceleration, in dry heat or cold*
- *Part 17: Combined contamination, solar radiation*
- *Part 18: Combined damp heat and low internal pressure*
- *Part 19: Temperature cycles combined with sinusoidal or random vibration*
- *Part 20: Humid atmosphere containing sulfur dioxide or hydrogen sulfide*

Annex A of this part of ISO 9022 is for information only.

iTeh STANDARD PREVIEW **(standards.iteh.ai)**

[ISO 9022-8:1994](https://standards.iteh.ai/catalog/standards/sist/e121f9df-192b-41d2-b919-d1f7ca8de723/iso-9022-8-1994)

<https://standards.iteh.ai/catalog/standards/sist/e121f9df-192b-41d2-b919-d1f7ca8de723/iso-9022-8-1994>

Introduction

Optical instruments are affected during their use by a number of different environmental parameters which they are required to resist without significant reduction in performance.

The type and severity of these parameters depend on the conditions of use of the instrument (for example, in the laboratory or workshop) and on its geographical location. The environmental effects on optical instrument performance in the tropics and subtropics are totally different from those found when they are used in the arctic regions. Individual parameters cause a variety of different and overlapping effects on instrument performance.

The manufacturer attempts to ensure, and the user naturally expects, that instruments will resist the likely rigours of their environment throughout their life. This expectation can be assessed by exposure of the instrument to a range of simulated environmental parameters under controlled laboratory conditions. The severity of these conditions is often increased to obtain meaningful results in a relatively short period of time.

In order to allow assessment and comparison of the response of optical instruments to appropriate environmental conditions, ISO 9022 contains details of a number of laboratory tests which reliably simulate a variety of different environments. The tests are based largely on IEC standards, modified where necessary to take into account features special to optical instruments.

It should be noted that, as a result of continuous progress in all fields, optical instruments are no longer only precision-engineered optical products, but, depending on their range of application, also contain additional assemblies from other fields. For this reason, the principal function of the instrument must be assessed to determine which International Standard should be used for testing. If the optical function is of primary importance, then ISO 9022 is applicable, but if other functions take precedence then the appropriate International Standard in the field concerned should be applied. Cases may arise where application of both ISO 9022 and other appropriate International Standards will be necessary.

Optics and optical instruments — Environmental test methods —

Part 8:

High pressure, low pressure, immersion

1 Scope

This part of ISO 9022 specifies methods for the testing of optical instruments and instruments containing optical components, under equivalent conditions, for their ability to resist high pressure, low pressure or immersion.

The purpose of testing is to investigate to what extent the optical, thermal, mechanical, chemical and electrical performance characteristics of the specimen are affected by high pressure, low pressure or immersion.

2 Normative reference

The following standard contains provisions which, through reference in this text, constitute provisions of this part of ISO 9022. At the time of publication, the edition indicated was valid. All standards are subject to revision, and parties to agreements based on this part of ISO 9022 are encouraged to investigate the possibility of applying the most recent edition of the standard indicated below. Members of IEC and ISO maintain registers of currently valid International Standards.

ISO 9022-1:1994¹⁾, *Optics and optical instruments — Environmental test methods — Part 1: Definitions, extent of testing.*

1) To be published.

3 General information and test conditions

Three different test methods are used to test the pressure-resistance of optical instruments:

- Conditioning method 80: High internal pressure.
- Conditioning method 81: Low internal pressure.
- Conditioning method 82: Immersion.

Environmental conditions for conditioning method 80: clean dry air or dry nitrogen, relative humidity less than 30 %.

Conditioning method 82 shall be used for instruments that may undergo immersion during service.

The immersion test shall be carried out in an open water container or in a water pressure chamber, using softened or demineralized water. The immersion depth specified relates to the uppermost point of the specimen. The water temperature shall be between 10 °C and 25 °C. During exposure, the temperature of the specimen shall not be lower than the water temperature; nor shall it exceed that temperature by more than 10 K.

4 Conditioning

4.1 Conditioning method 80: High internal pressure

See table 1.

4.2 Conditioning method 80: Low internal pressure

See table 2.

4.3 Conditioning method 82: Immersion

See table 3.

5 Procedure

5.1 General

The test shall be conducted in accordance with the requirements of the relevant specification and with ISO 9022-1.

5.2 Conditioning method 82: Preconditioning of specimen and initial test

Prior to exposure, the specimen shall be conditioned at a temperature of $40\text{ °C} \pm 2\text{ °C}$ and a relative humidity of less than 40 % for a period of 4 h.

Table 1 — Degrees of severity for conditioning method 80: High internal pressure

Degree of severity		01	02	03	04	05	06	07	08	09	10	11	12	13
Difference from ambient pressure	hPa	100 ± 2						400 ± 5						
Maximum pressure drop	hPa	75	50	20	10	5	2	300	200	100	50	20	10	5
Exposure time	min	10												
State of operation		1 or 2 1)												
1) See 5.4.														

iTeh STANDARD PREVIEW
(standards.iteh.ai)

ISO 9022-8:1994

<https://standards.iteh.ai/catalog/standards/sist/e121f9df-192b-41d2-b919-d1f7ca8de723/iso-9022-8-1994>

Table 2 — Degrees of severity for conditioning method 81: Low internal pressure

Degree of severity		01	02	03	04	05	06	07	08	09	10	11	12	13
Difference from ambient pressure	hPa	100 ± 2						400 ± 5						
Maximum pressure rise	hPa	75	50	20	10	5	2	300	200	100	50	20	10	5
Exposure time	min	10												
State of operation		1 or 2 1)												
1) See 5.4.														

Table 3 — Degrees of severity for conditioning method 82: Immersion

Degree of severity		01	02	03	04	05	06
Immersion depths	m	1	4	10	50	200	400
	Allowable deviation	± 10 %					
Exposure time	h	2					
State of operation		1 or 2					

5.3 Conditioning methods 80 and 81: Pressure change curve

If required by the relevant specification, a graphical representation of the pressure change time history shall be recorded during testing. In the event that a suitable recorder is not available, the pressure change curve shall be plotted from not less than 10 values measured at equal intervals (see annex A).

5.4 State of operation 2

If, in the relevant specification, state of operation 2 is required for conditioning methods 80 and 81, the following points shall be taken into consideration:

- a) thermal changes, within or on the specimen shall not exceed 1 K as, otherwise, the required measurement accuracy will be degraded;
- b) mechanical motions may be initiated from the outside, e.g. manually, thus replacing state of operation 2;
- c) in the event that mechanical motion causes changes of volume with the specimen, the resulting discontinuities in the recording of the event shall be identified.

5.5 Conditioning method 82: Recovery and final test

After completion of exposure, the specimen shall be conditioned at a temperature of $40\text{ °C} \pm 2\text{ °C}$ and a relative humidity of less than 40 % for a period of 4 h and then assessed in accordance with 5.6.

5.6 Conditioning method 82: Evaluation

Initial and final tests should not reveal moisture film on optical surfaces. Moisture film will be acceptable provided that it disappears during heating of the specimen and does not reappear within 24 h after completion of the test. The results of specimen evaluation shall be compared in accordance with 5.2 and 5.5. The relevant specification shall specify acceptable differences.

If, on account of the specimen design (e.g. closed casing), a visual inspection cannot reveal penetration of water, the relevant specification shall specify a method of detecting penetrated moisture.

6 Environmental test code

The environmental test code shall be as defined in ISO 9022-1.

EXAMPLE

The environmental test of optical instruments for pressure-resistance in the event of internal low pressure, conditioning method 81, degree of severity 01, state of operation 1, shall be identified as:

Environmental test ISO 9022-81-01-1

7 Specification

The relevant specification shall contain the following details:

- a) environmental test code;
- b) number of specimens;
- c) preconditioning (see 5.2);
- d) type and scope of initial test (see 5.2);
- e) conditioning methods 80 and 81: if recording of a pressure change curve in accordance with 5.3 is required, criteria for evaluation;
- f) state of operation 2: period of operation;
- g) state of operation 2: type and scope of intermediate test;
- h) recovery (see 5.5);
- i) type and scope of final test (see 5.5);
- j) criteria for evaluation (see 5.6);
- k) type and scope of test report.

Annex A (informative)

Explanatory notes

For the sake of satisfactory functioning, it is essential that changes of temperature do not cause moisture films on internal surfaces since, otherwise, the optical performance would be considerably degraded and other effects such as corrosion or mould growth might be accelerated. This requirement can normally be satisfied by sealing the instrument before use with dry air or nitrogen and by defining the pressure-resistance of the instrument.

Therefore, in order to ensure proper functioning it is necessary to investigate the pressure-resistance. Depending upon the air volume of the instrument and the number of enclosure interfaces, or the functional bushings inserted into the enclosure wall (in other words, depending upon the number and type of enclosure sealings), reasonable pressure-resistance requirements need to be selected and defined choosing a mission-orientated environment and conditioning method.

Instruments used and transported and thus exposed to maximum stress in high-altitude environments therefore have to be pressure-tested at high internal pressure, whereas instruments which are exposed to maximum stress in environments of low temperature or high external pressure have to be pressure-tested at low internal pressure (testing at low internal pres-

sure also presents a higher degree of safety from contamination and increased internal humidity).

Skin-diving or underwater instruments shall be immersion-tested.

Recording the pressure/time history from discrete data measured during testing at high internal pressure (conditioning method 80) or low internal pressure (conditioning method 81) permits an appropriate interpretation of the tightness measured and a reasonable determination of the expected service reliability.

The use of piezoelectric or piezoresistive pressure transducers together with the associated measuring amplifiers ensures a high degree of measurement accuracy. Wherever possible, the sensor should be installed within the test adapter in order to avoid air volumes outside the specimen. Moreover, this arrangement facilitates the connection of a recording unit, e.g. an X-T-recorder, thus enabling immediate charting.

A schematic representation of a pressure test apparatus for test methods 80 and 81 is given in figure A.1.

Figure A.2 shows a test connection for the pressure test.

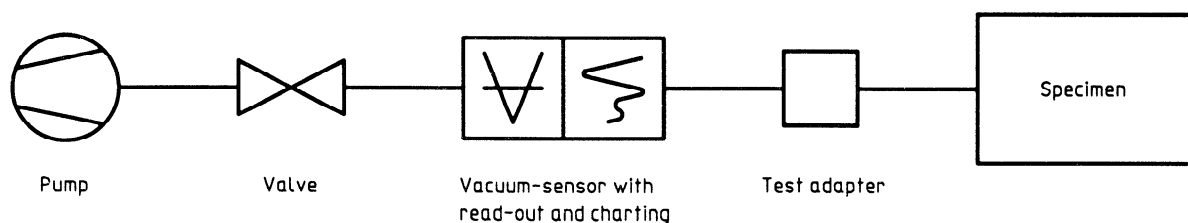
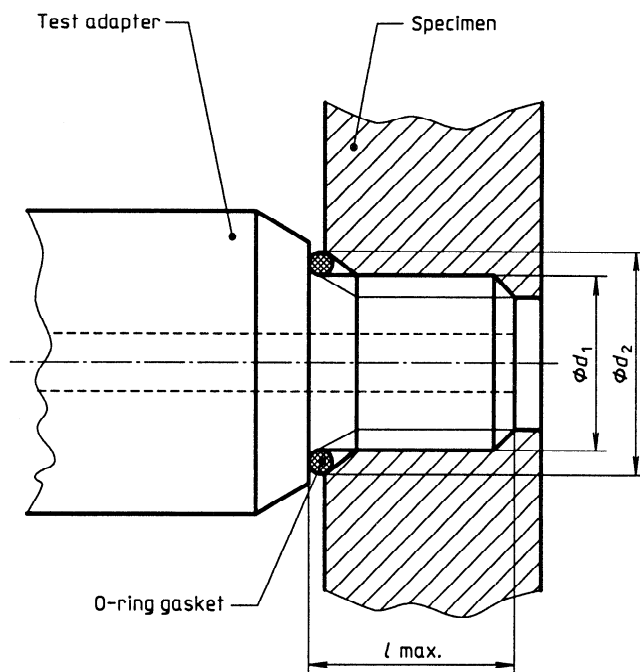

Figure A.1 — Schematic representation of pressure test apparatus suitable for test methods 80 and 81

Dimension in millimetres



Thread	M3	M6	M10	M16 × 1,5 ¹⁾	M24 × 1,5 ¹⁾	M36 × 1,5 ¹⁾
d_1						
d_2	6	9	14	21	29	42
$l \text{ max.}$	5	8	12		15	

1) Desiccator cartridge connection.

ISO 9022-8:1994

<https://standards.iteh.ai/catalog/standards/sist/e121f9df-192b-41d2-b919-11f7ca7d7236/iso-9022-8-1994>

Figure A.2 — Test connection for pressure test