



Designation: C 1134 – 90 (Reapproved 1995)<sup>ε1</sup>

## Standard Test Method for Water Retention of Rigid Thermal Insulations Following Partial Immersion<sup>1</sup>

This standard is issued under the fixed designation C 1134; the number immediately following the designation indicates the year of original adoption or, in the case of revision, the year of last revision. A number in parentheses indicates the year of last reapproval. A superscript epsilon ( $\epsilon$ ) indicates an editorial change since the last revision or reapproval.

<sup>ε1</sup> NOTE—Safety caveat was updated and keywords were added editorially in March 1995.

### 1. Scope

1.1 This test method determines the amount of water retained (including surface water) by rigid block and board thermal insulations used in building construction applications after these materials have been partially immersed in liquid water for prescribed time intervals under isothermal conditions. This test method is intended to be used for the characterization of materials in the laboratory. It is not intended to simulate any particular environmental condition that may be encountered in building construction applications.

1.2 This test method does not address all the possible mechanisms of water intake and retention and related phenomena for rigid thermal insulations. It relates only to those conditions outlined in 1.1. Determination of moisture accumulation in thermal insulations due to complete immersion, water vapor transmission, internal condensation, freeze-thaw cycling, or a combination of these effects requires different test procedures.

1.3 Each partial immersion interval is followed by a brief free-drainage period. This test method does not address or attempt to quantify the drainage characteristics of materials. Therefore, results for materials with different internal structure and porosity, such as cellular materials and fibrous materials, may not be directly comparable. Also, test results for specimens of different thickness may not be directly comparable because of porosity effects. The surface characteristics of a material also affect drainage. Specimens with rough surfaces may retain more surface water than specimens with smooth surfaces, and surface treatment during specimen preparation may affect water intake and retention. Therefore, results for materials with different surface characteristics may not be directly comparable.

1.4 For most materials the size of the test specimens is small compared with the size of the products actually installed in the field. If the surface-to-volume ratios for the test specimens and the corresponding products are different, the test results may be misleading.

<sup>1</sup> This test method is under the jurisdiction of ASTM Committee C-16 on Thermal Insulation and is the direct responsibility of Subcommittee C16.33 on Thermal Insulation Finishes and Vapor Transmission.

Current edition approved Jan. 10, 1990. Published February 1990.

1.5 The values stated in SI units are to be regarded as standard, but the results may also be reported in inch-pound (I-P) units. In this standard I-P units are given in parentheses for information purposes and may be approximate.

1.6 *This standard does not purport to address all of the safety concerns, if any, associated with its use. It is the responsibility of the user of this standard to establish appropriate safety and health practices and determine the applicability of regulatory limitations prior to use.*

### 2. Referenced Documents

#### 2.1 ASTM Standards:

C 168 Terminology Relating to Thermal Insulating Materials<sup>2</sup>

E 691 Practice for Conducting an Interlaboratory Study to Determine the Precision of a Test Method<sup>3</sup>

### 3. Terminology

3.1 *Definitions*—Terminology C 168 applies to terms used in this test method.

#### 3.2 Descriptions of Terms Specific to This Standard:

3.2.1  $WR_S$ —short-term water retention rating, the average of the water retained following the 0.75-h and 3.00-h partial immersion intervals, kilograms per square metre (percent by volume) (for materials tested at 25.4 mm (1.00 in.) thickness). (See 4.2.)

3.2.2  $WR_L$ —long-term water retention rating, the water retained following the 168-h partial immersion interval, kilograms per square metre (percent by volume) (for materials tested at 25.4 mm (1.00 in.) thickness). (See 4.2.)

### 4. Significance and Use

4.1 Materials less than or equal to 15.0 mm (0.59 in.) in thickness shall not be tested in accordance with this test method in order to avoid complete immersion of the specimens. This type of exposure is beyond the scope of this test method.

4.2 Materials shall be tested at both actual product thickness and 25.4 mm (1.00 in.) thickness provided the materials can be

<sup>2</sup> Annual Book of ASTM Standards, Vol 04.06.

<sup>3</sup> Annual Book of ASTM Standards, Vol 14.02.

cut to a thickness of 25.4 mm without changing the original character of the materials. If a product cannot be cut without changing the original character of the material, the test report shall contain an appropriate note to this effect. Results shall be reported on the basis of equal nominal wetted specimen surface area (in units of kilograms per square metre) for materials tested at actual product thickness and on the basis of equal specimen volume (in units of percent by volume) for materials tested at 25.4 mm thickness. If a product cannot be cut to a thickness of 25.4 mm or if the actual product thickness is less than 25.4 mm but greater than 15.0 mm (0.59 in.), the product shall only be tested at actual product thickness and results only reported on the basis of equal nominal wetted specimen surface area.

4.2.1 By reporting results on the basis of equal nominal wetted specimen surface area, specimens of different thicknesses can be compared equitably. For some specimens, the water intake and retention primarily may depend on the nominal wetted surface area available for water intake.

4.2.2 By reporting results on the basis of equal specimen volume, specimens can be compared equitably using units that commonly are selected to represent results of water intake testing (percent by volume). For some materials, water intake and retention primarily may depend on the volume of the specimen available for water intake.

4.2.3 In most cases water retention is a secondary performance characteristic that has an influence on a primary performance characteristic, such as thermal performance, surface accumulation of moisture (that may contribute to fungal growth), localized collection of electrolytes (that may contribute to corrosion), etc. Depending on the primary performance characteristic that is of interest, the preferred units for use in comparing the water retention of different materials may be either kilograms per square metre or percent by volume.

4.3 Immersion times in addition to those required by this test method may be selected provided that all parties involved are in agreement.

4.4 The water retention characteristics of materials may be affected by conditions such as elevated temperatures or chemical exposures.

## 5. Apparatus

5.1 *Test Chamber*—The test chamber or room where the test is to be run shall be maintained at a temperature of  $23 \pm 2^\circ\text{C}$  ( $73 \pm 4^\circ\text{F}$ ) and a relative humidity of  $50 \pm 5\%$ .

5.2 *Immersion Tank*—The immersion tank shall consist of an open tank of sufficient size to accommodate at least three specimens. Included in the construction of the tank shall be a means for securing the specimens in a level position, that is, a noncorrosive support for the bottom surface of the specimens and a similar constraining device for the top surface. The support and constraining devices shall not contact more than 15 % of the specimen surfaces. The pressure exerted on the specimens by the constraining device for the top surface shall be limited to that required to counteract any buoyant force exerted by the specimens at the beginning of the test. The immersion tank shall be provided with a water overflow level, as shown in Fig. 1.

5.3 *Balance*—The balance shall have a sensitivity of at least

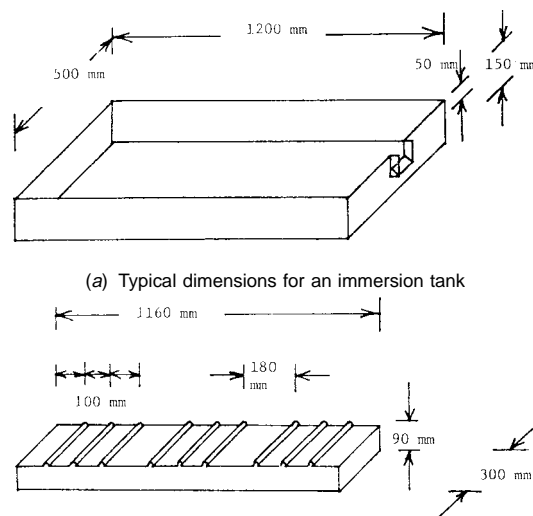

(b) Typical dimensions for a noncorrosive support for the specimens

FIG. 1 Immersion Tank

0.1 g. For some measurements such a sensitivity may be more than is required, in which case a sensitivity of at least 0.1 % of the total mass of the specimen after immersion and the weighing container is acceptable. See 7.4.1. To achieve these sensitivities, two different balances may be required.

5.4 *Weighing Container*—The weighing container shall be made of a nonabsorbent, waterproof, lightweight material and shall be large enough to allow a specimen to be laid flat in the container.

5.5 *Linear Measuring Instrument*—The linear measuring instrument shall be capable of measuring specimen dimensions to the nearest 0.2 mm (0.01 in.).

5.6 *Distilled or Deionized Water*—Distilled or deionized water shall be used for testing.

5.7 *Drainage Rack*—The drainage rack shall be similar to that shown in Figs. 2 and 3.

## 6. Test Specimens

6.1 Six test specimens shall be selected randomly from each sample. Only three specimens are required if the product is only to be tested at the actual product thickness or if the actual product thickness is 25.4 mm (1.00 in.). See 4.2.

6.2 The test specimens shall be square with a length and width of  $300 \pm 10$  mm ( $11.8 \pm 0.4$  in.). The thickness of three of the specimens shall be the same as that of the product or sample from which the specimens are taken. The thickness of the other three specimens shall be  $25.4 \pm 1.6$  mm ( $1.00 \pm 0.06$  in.), provided the material is greater than 25.4 mm in thickness. Specimens shall be cut to this size from thicker stock if appropriate. See 4.2.

6.3 *Specimen Preparation:*

6.3.1 Materials normally produced with natural skins or specially cut surfaces shall be tested with at least one skin or surface intact, and that skin or surface shall be placed in contact with the water when the test is conducted. The test report shall contain an appropriate note.

6.3.2 Composite materials normally produced with facings or laminates may be tested with or without facings, as required

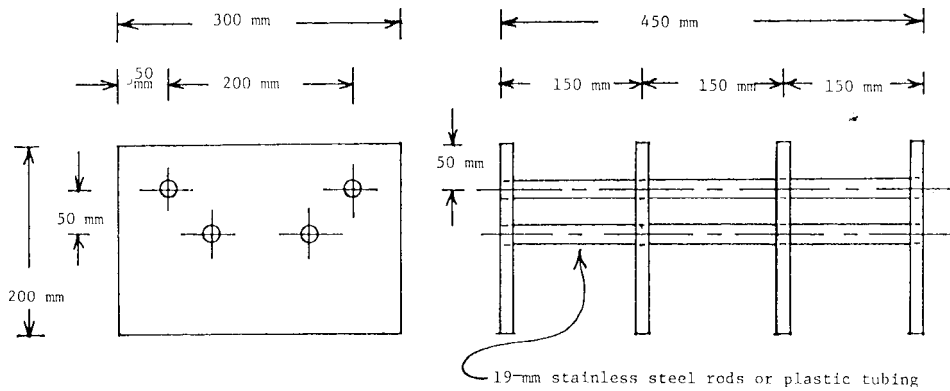

FIG. 2 Drainage Rack for Three Specimens

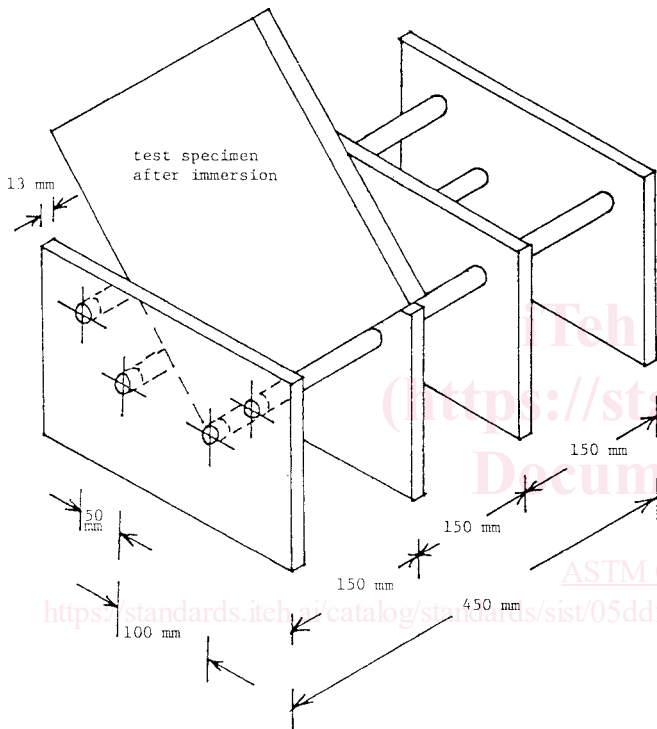

FIG. 3 Test Specimen in Drainage Rack

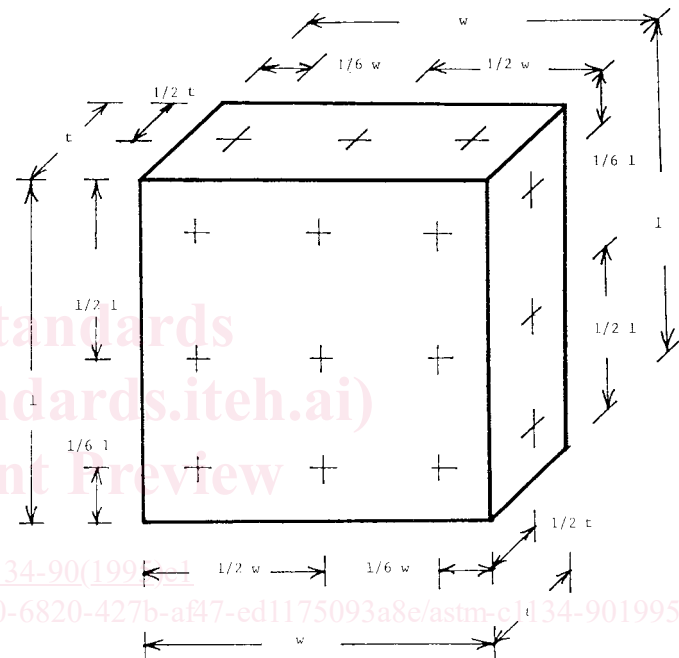

FIG. 4 Measurement Locations for Determining Test Specimen Dimensions

by the appropriate material specification. The test report shall contain an appropriate note.

6.3.3 Care must be taken to avoid making indentations when handling specimens. Any specimens having surface indentations greater than 5.0 mm (0.20 in.) in depth or any specimens damaged during preparation shall be rejected and replaced by new specimens prior to testing.

**7. Procedure**

7.1 Measure test specimen dimensions (length,  $l$ , width,  $w$ , and thickness,  $t$ ) to the nearest 0.2 mm (0.01 in.). Measure both the length and width at three different locations and the thickness at nine different locations, as shown in Fig. 4. The average of each set of dimensions shall be used to calculate the volume,  $V$ , of the specimen.

7.2 Record the initial mass of each specimen to the nearest 0.1 g, and condition the specimens to constant mass in the laboratory at a temperature of  $23 \pm 2^\circ\text{C}$  ( $73 \pm 4^\circ\text{F}$ ) and a

relative humidity of  $50 \pm 5\%$ . Allow at least 24 h for the initial conditioning period and then at least 4 h for each additional period as needed. Continue conditioning until specimens reach constant mass as indicated by a change in mass of 0.2 g or less between successive weighings. Record the dry mass,  $M_0$ , of each specimen to the nearest 0.1 g.

7.3 Using nonabsorbent dummy blocks of the same size as the test specimens, adjust the support and constraining devices so that the dummy blocks are horizontal and level. Make certain that the immersion tank is also level. Adjust the water level in the immersion tank so that it is  $10.0 \pm 1.6$  mm ( $0.39 \pm 0.06$  in.) above the bottom surface of the dummy blocks. Remove the dummy blocks and replace them with the actual test specimens. If necessary, add water to ensure that the specimens are immersed to the required depth. If the immersion tank is not provided with an automatic adjustment for the water level, add water at least once during each 24-h period to ensure that the specimens are immersed to the required depth.

7.4 Remove and weigh the specimens at the following time intervals:  $0.75 \pm 0.03$  h,  $3.00 \pm 0.15$  h, and  $168 \pm 4$  h. These