

INTERNATIONAL STANDARD

ISO
9073-2

Second edition
1995-03-15

Textiles — Test methods for nonwovens —

Part 2: Determination of thickness (standards.iteh.ai)

*Textiles — Méthodes d'essai pour nontissés —
Partie 2: Détermination de l'épaisseur*
<https://standards.iteh.ai/catalog/standards/sist/4c0f7e25-939c-44fc-b807-665cd10d52f0/iso-9073-2-1995>

INTERNATIONAL

ISO



Reference number
ISO 9073-2:1995(E)

Foreword

ISO (the International Organization for Standardization) is a worldwide federation of national standards bodies (ISO member bodies). The work of preparing International Standards is normally carried out through ISO technical committees. Each member body interested in a subject for which a technical committee has been established has the right to be represented on that committee. International organizations, governmental and non-governmental, in liaison with ISO, also take part in the work. ISO collaborates closely with the International Electrotechnical Commission (IEC) on all matters of electrotechnical standardization.

Draft International Standards adopted by the technical committees are circulated to the member bodies for voting. Publication as an International Standard requires approval by at least 75 % of the member bodies casting a vote.

International Standard ISO 9073-2 was prepared by Technical Committee ISO/TC 38, *Textiles*.

This second edition cancels and replaces the first edition (ISO 9073-2:1989), which has been technically revised.

ISO 9073 consists of the following parts, under the general title *Textiles* — *Test methods for nonwovens*:

- Part 1: *Determination of mass per unit area*
- Part 2: *Determination of thickness*
- Part 3: *Determination of tensile strength and elongation*
- Part 4: *Determination of tear resistance*
- Part 5: *Determination of bursting stress*
- Part 6: *Determination of absorption*
- Part 7: *Determination of bending length*
- Part 8: *Determination of liquid strike-through time (simulated urine)*
- Part 9: *Determination of drape coefficient*

© ISO 1995

All rights reserved. Unless otherwise specified, no part of this publication may be reproduced or utilized in any form or by any means, electronic or mechanical, including photocopying and microfilm, without permission in writing from the publisher.

International Organization for Standardization
Case Postale 56 • CH-1211 Genève 20 • Switzerland

Printed in Switzerland

Introduction

Although nonwovens are classified within the textile industry, it should be recognized that nonwovens technologically share characteristics not only with textile products but also with paper and/or plastic products. There is an existing international textile test for the determination of thickness, ISO 5084:—, *Textiles — Determination of the thickness of textiles and textile products (other than textile floor coverings, nonwovens and geotextiles)* [to be published (revision of ISO 5084:1977)]. However, in order to meet the specific needs of nonwovens, alternative requirements to those listed in ISO 5084 are specified in this part of ISO 9073. These are

- a) a different sampling procedure;
- b) specific pressures at which to test normal and bulky nonwovens;
- c) a specific area for the size of the presser-foot;
- d) a shorter time to note the gauge reading.

<https://standards.iteh.ai/catalog/standards/sist/4c0f3e25-939c-44fc-b807-665cdf0d52f0/iso-9073-2-1995>

iTeh STANDARD PREVIEW
This page intentionally left blank
(standards.iteh.ai)

[ISO 9073-2:1995](https://standards.iteh.ai/catalog/standards/sist/4c0f3e25-939c-44fc-b807-665cdf0d52f0/iso-9073-2-1995)

<https://standards.iteh.ai/catalog/standards/sist/4c0f3e25-939c-44fc-b807-665cdf0d52f0/iso-9073-2-1995>

Textiles — Test methods for nonwovens —

Part 2: Determination of thickness

1 Scope

This part of ISO 9073 specifies methods for the determination of the thickness, when under a specific pressure, of normal and bulky nonwoven textiles.

2 Normative references

The following standards contain provisions which, through reference in this text, constitute provisions of this part of ISO 9073. At the time of publication, the editions indicated were valid. All standards are subject to revision, and parties to agreements based on this part of ISO 9073 are encouraged to investigate the possibility of applying the most recent editions of the standards indicated below. Members of IEC and ISO maintain registers of currently valid International Standards.

ISO 139:1973, *Textiles — Standard atmospheres for conditioning and testing*.

ISO 186:1994, *Paper and board — Sampling to determine average quality*.

3 Definitions

For the purposes of this part of ISO 9073, the following definitions apply.

3.1 bulky nonwoven: Nonwoven textile which is compressible by 20 % or more when the pressure applied changes from 0,1 kPa to 0,5 kPa.

3.2 thickness: Distance between the face and back of a nonwoven, measured as the distance between a reference plate on which the nonwoven rests and a parallel presser-foot that is applying a pressure to the nonwoven.

4 Principle

Measurement of the thickness of a nonwoven as the distance between the reference plate on which the nonwoven rests and a parallel presser-foot that exerts a specified pressure on the area under test.

5 Apparatus

5.1 For normal nonwovens

5.1.1 Two circular horizontal plates, attached to a stand, comprising an upper plate, or presser-foot, capable of moving vertically and having an area of approximately 2 500 mm², and a reference plate having a plane surface of diameter at least 50 mm greater than that of the presser-foot.

5.1.2 Measuring device, having a scale with 0,01 mm graduations, for measuring the distance between the reference plate and the presser-foot (5.1.1).

5.2 For bulky nonwovens with a maximum thickness of 20 mm

NOTE 1 An example of suitable test apparatus is shown in figure 1.

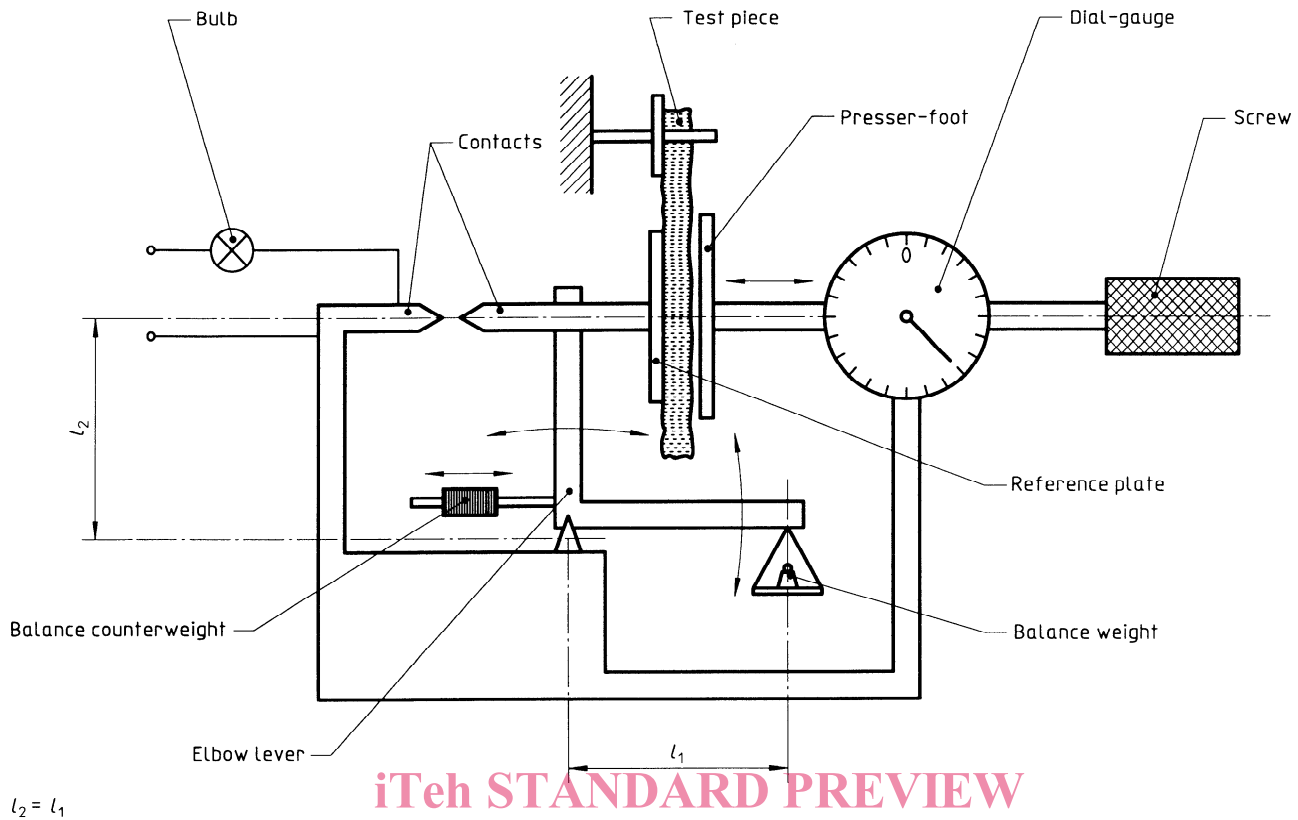

Figure 1 — Test apparatus for bulky nonwovens with a maximum thickness of 20 mm

ISO 9073-2:1995

<https://standards.iteh.ai/catalog/standards/sist/4c0f3e25-939c-44fc-b807-665cdf0d52f0/iso-9073-2-1995>

5.2.1 Vertical reference plate, with an area of 1 000 mm², **presser-foot** with an area of 2 500 mm², and equipment to suspend the test piece vertically between them.

5.2.2 Elbow lever, with both arms of equal length, attached to the reference plate and capable of being balanced using a counterweight so that it exerts a very small force to the left when the balance weight (5.2.4) is not in position. The geometry of the lever is such that the balance weight gives a measuring pressure of 0,02 kPa.

5.2.3 Electrical contacts, which, when closed, cause a small bulb to become illuminated.

5.2.4 Balance weight, with a mass of 2,05 g ± 0,05 g, which, when in position, causes the contacts (5.2.3) to separate and extinguish the bulb.

5.2.5 Screw, which, when turned, drives the presser-foot to the left and presses the test piece with increasing pressure against the reference plate until the force on the balance is overcome and the bulb becomes illuminated.

5.2.6 Dial-gauge, to indicate the distance, in millimetres, between the reference plate and the presser-foot corresponding to the thickness of the test piece at the pressure applied.

5.3 For bulky nonwovens with a thickness greater than 20 mm

NOTE 2 An example of suitable test apparatus is shown in figure 2.

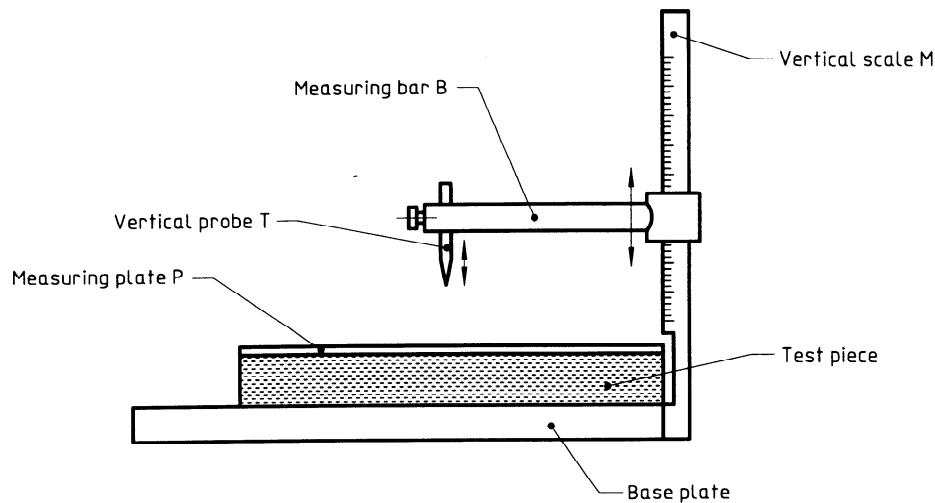

Figure 2 — Test apparatus for bulky nonwovens with a thickness greater than 20 mm

5.3.1 Horizontal square base plate, measuring 300 mm × 300 mm, having a smooth surface. In the centre of one side is a **vertical scale M** with graduations in millimetres, on which is placed a **horizontal measuring bar B**, which is movable in a vertical direction. This bar supports an **adjustable vertical probe T** at a distance of 100 mm from the vertical scale.

NOTE 3 The vertical probe T should be above the centre of the measuring plate P when in use (see 9.3.2), such that the measuring plate is not in contact with the scale.

5.3.2 Square measuring plate P, measuring $(200 \text{ mm} \pm 0,2 \text{ mm}) \times (200 \text{ mm} \pm 0,2 \text{ mm})$ and a mass of $82 \text{ g} \pm 2 \text{ g}$, made of glass with a thickness of 0,7 mm, which can be brought to the required mass by the addition of weight-pieces to give a measuring pressure of 0,02 kPa.

NOTE 4 If additional weight-pieces are necessary, they should be distributed symmetrically so that there is even pressure over the whole area of the plate.

5.4 Stopwatch.

6 Sampling

Carry out sampling in accordance with ISO 186, ensuring that the areas from which the specimens are taken have no visible flaws and are not creased.

NOTE 5 This method of sampling recognizes and makes provisions for "anisotropy" (differences in properties along various directions, principally machine and cross directions) in the final specimens. However, these specimens are ran-

dom representatives of the material and in some cases it may be desirable to investigate systematic variations of properties (including anisotropy), for example across the width, or in certain positions along the length, of a given reel. In all such cases, special provisions should be agreed between purchaser and vendor and recorded in the test report. A procedure for more detailed examination of variability within a given batch of material is available in TAPPI T 74-05-11 and may be found helpful. This publication may be obtained from: The Technical Association of Pulp and Paper Industries, 1 Dunwoody Park, Atlanta, GA 30338, USA.

7 Preparation and conditioning of test pieces

7.1 If the method of test [A, B or C (see clause 9)] has not been determined, cut 10 preliminary test pieces, each having an area larger than $2\,500 \text{ mm}^2$, and, after conditioning, carry out the procedure described in clause 8.

7.2 For normal nonwovens, cut 10 test pieces, each having an area larger than $2\,500 \text{ mm}^2$.

7.3 For bulky nonwovens with a maximum thickness of 20 mm, cut 10 test pieces, each having an area of $(130 \text{ mm} \pm 5 \text{ mm}) \times (80 \text{ mm} \pm 5 \text{ mm})$.

7.4 For bulky nonwovens with a thickness greater than 20 mm, cut 10 test pieces, each having an area of $(200 \text{ mm} \pm 0,2 \text{ mm}) \times (200 \text{ mm} \pm 0,2 \text{ mm})$.

7.5 Condition the test pieces as specified in ISO 139.

8 Preliminary procedure

8.1 Carry out the tests in the standard atmosphere for testing (see ISO 139).

8.2 Using the apparatus specified in 5.1, adjust the load on the presser-foot according to the manufacturer's instructions to give a uniform pressure of 0,1 kPa and set the measuring device to zero.

8.3 Raise the presser-foot and place the preliminary test piece (7.1) carefully, without tension, on the reference plate. Ensure the test piece is positioned centrally with respect to the presser-foot. Lower the presser-foot carefully until contact is made with the test piece.

8.4 Leave in contact for 10 s, adjust the measuring device to measure the thickness of the sample, and note the reading, in millimetres.

8.5 Repeat the procedure for the other nine test pieces.

8.6 Adjust the load on the presser-foot according to the manufacturer's instructions to give a uniform pressure of 0,5 kPa and adjust the measuring device to zero. Repeat the measurements on the same 10 test pieces.

8.7 Calculate the difference between the results at pressures of 0,1 kPa and 0,5 kPa for each preliminary test piece and determine the mean thickness of the nonwoven.

NOTE 6 It is recommended that reference specimens of known thickness are used to check the testing apparatus periodically.

8.8 Test the nonwovens which were compressed by < 20 % of their thickness in this preliminary procedure in accordance with the procedure given in 9.1 (method A) and others in accordance with either 9.2 (method B) or 9.3 (method C), depending upon whether they have a thickness of less than or greater than 20 mm.

NOTE 7 When different samples, close to the limits of each method, are to be compared, the comparison should be made using the same method.

9 Procedure

9.1 Method A for normal nonwovens

9.1.1 Carry out the tests in the standard atmosphere for testing (see ISO 139).

9.1.2 Using the apparatus specified in 5.1, adjust the load on the presser-foot according to the manufacturer's instructions to give a uniform pressure of 0,5 kPa and set the measuring device to zero.

9.1.3 Raise the presser-foot, and position the test piece (7.2) centrally with respect to the presser-foot, and without tension, on the reference plate.

9.1.4 Lower the presser-foot carefully until contact is made with the test piece, and leave in contact for 10 s.

9.1.5 Adjust the measuring device and note the reading, in millimetres.

9.1.6 Repeat the procedure on the other nine test pieces.

9.2 Method B for bulky nonwovens with a maximum thickness of 20 mm

9.2.1 Carry out the tests in the standard atmosphere for testing (see ISO 139).

9.2.2 Using the apparatus specified in 5.2, check that the sensitivity and zero are adjusted correctly when the balance weight of 2,05 g ± 0,05 g is in position.

9.2.3 Move the presser-foot to the right and fasten the test piece (7.3) on the bearer pin so that it is suspended between the reference plate and the presser-foot.

9.2.4 Move the presser-foot slowly to the left by means of the screw until the bulb is illuminated.

9.2.5 After 10 s, read the thickness, in millimetres, from the dial-gauge, to the nearest 0,1 mm.

NOTE 8 If further compression of the test piece during the 10 s period causes the contact to separate, the presser-foot should be adjusted to illuminate the bulb again before the thickness is read from the gauge.

9.2.6 Repeat the procedure for the other nine test pieces.

9.3 Method C for bulky nonwovens with a thickness greater than 20 mm

9.3.1 Carry out the tests in the standard atmosphere for testing (see ISO 139).

9.3.2 Using the apparatus specified in 5.3, place the measuring plate on the base plate and, if necessary, adjust the height of the probe so that the reading on the scale is zero when the probe just touches the centre of the measuring plate.

9.3.3 Place the test piece (7.4) centrally under the probe and place the measuring plate squarely on top of the test piece without applying excess pressure.

9.3.4 After 10 s, move the measuring bar downwards until the probe touches the surface of the measuring plate, and read the thickness from the scale, to the nearest 0,5 mm.

9.3.5 Repeat the test procedure for the other nine test pieces.

10 Expression of results

Use the 10 results obtained to calculate the mean

thickness of the nonwoven, in millimetres, and, if required, the coefficient of variation.

11 Test report

The test report shall include the following information:

- a) the number and year of publication of this part of ISO 9073, i.e. ISO 9073-2:1995;
- b) all details necessary for the identification of the material;
- c) the mean thickness of the nonwoven, in millimetres (see clause 10) and, if required, the coefficient of variation;
- d) the test method used;
- e) the conditioning atmosphere used;
- f) any unusual features noted during the testing, or deviations from the standard procedure;
- g) details of any reference specimens used (see note 6).

iTech STANDARD PREVIEW
(standards.iteh.ai)
<https://standards.iteh.ai/catalog/standards/sist/4c0f3e25-939c-44fc-b807-665cdf0d52f0/iso-9073-2-1995>