

INTERNATIONAL STANDARD

ISO
9073-7

First edition
1995-12-15

Textiles — Test methods for nonwovens —

Part 7:

Determination of bending length
(standards.iteh.ai)

Textiles ~~ISO~~ *Méthodes d'essai pour nontissés —*
<https://standards.iteh.ai/catalog/standards/sist/add50874-a2ef-4c78-a687-645eb3a9066f/iso-9073-7-1995>
Partie 7. Détermination de la longueur de flexion



Reference number
ISO 9073-7:1995(E)

Foreword

ISO (the International Organization for Standardization) is a worldwide federation of national standards bodies (ISO member bodies). The work of preparing International Standards is normally carried out through ISO technical committees. Each member body interested in a subject for which a technical committee has been established has the right to be represented on that committee. International organizations, governmental and non-governmental, in liaison with ISO, also take part in the work. ISO collaborates closely with the International Electrotechnical Commission (IEC) on all matters of electrotechnical standardization.

Draft International Standards adopted by the technical committees are circulated to the member bodies for voting. Publication as an International Standard requires approval by at least 75 % of the member bodies casting a vote.

International Standard ISO 9073-7 was prepared by Technical Committee ISO/TC 38, *Textiles*.

ISO 9073 consists of the following parts, under the general title *Textiles* — *Test methods for nonwovens*:

- Part 1: *Determination of mass per unit area*
- Part 2: *Determination of thickness*
- Part 3: *Determination of tensile strength and elongation*
- Part 4: *Determination of tear resistance*
- Part 7: *Determination of bending length*
- Part 8: *Determination of liquid strike-through time (simulated urine)*
- Part 9: *Determination of drape coefficient*

Annex A of this part of ISO 9073 is for information only.

© ISO 1995

All rights reserved. Unless otherwise specified, no part of this publication may be reproduced or utilized in any form or by any means, electronic or mechanical, including photocopying and microfilm, without permission in writing from the publisher.

International Organization for Standardization
Case Postale 56 • CH-1211 Genève 20 • Switzerland

Printed in Switzerland

Textiles — Test methods for nonwovens —

Part 7: Determination of bending length

1 Scope

This part of ISO 9073 specifies a method for determining the bending length of a nonwoven fabric. An equation is given for calculating the flexural rigidity of the fabric from the bending length.

The method is not applicable to combination-type materials (composites or laminates) in which there can be a natural twist.

NOTE 1 This International Standard describes a test method specific to nonwovens. Other International Standards applicable to textile, paper, plastics, rubber or other materials can also be applied to test certain nonwoven characteristics.

2 Normative references

The following standards contain provisions which, through reference in this text, constitute provisions of this part of ISO 9073. At the time of publication, the editions indicated were valid. All standards are subject to revision, and parties to agreements based on this part of ISO 9073 are encouraged to investigate the possibility of applying the most recent editions of the standards indicated below. Members of IEC and ISO maintain registers of currently valid International Standards.

ISO 139:1973, *Textiles — Standard atmospheres for conditioning and testing*.

ISO 186:1994, *Paper and board — Sampling to determine average quality*.

ISO 9073-1:1989, *Textiles — Test methods for nonwovens — Part 1: Determination of mass per unit area*.

3 Definitions

For the purposes of this part of ISO 9073, the following definitions apply.

3.1 bending length: Length of a rectangular strip of fabric, fixed at one end and free at the other, that will bend under its own weight to an angle of $7,1^\circ$.

3.2 flexural rigidity: Ratio of small changes in bending moment per unit width of the material to corresponding small changes in curvature.

NOTE 2 Flexural rigidity can be calculated from the bending length.

4 Principle

A rectangular strip of fabric is supported on a horizontal platform with the long axis of the strip parallel to the long axis of the platform. The strip is advanced in the direction of its length so that an increasing part overhangs the platform and bends down under its own weight. The overhang is free at one end, and fixed at the other from the pressure applied by a slide on the part of the test piece still on the platform.

When the leading edge of the test piece has reached a plane passing through the edge of the platform and inclined at an angle of $41,5^\circ$ below the horizontal, the overhanging length will equal twice the bending length of the test piece (see annex A), and thus the bending length can be calculated.

5 Apparatus

A suitable apparatus is shown in figure 1.

5.1 Level table.

5.2 Platform, of width (40 ± 2) mm and length (200 ± 2) mm, supported at a height of at least 150 mm above the surface of the table (5.1). Each side of the platform support shall be transparent and marked with a line (L_1 and L_2 respectively; see figure 1) running from the end of the platform at an angle of $41,5^\circ$ below the horizontal.

A mark (D) shall be made on the platform at (10 ± 1) mm from the front edge (see figure 1).

NOTE 3 To avoid adherence of the test piece, the platform should be coated or covered with polytetrafluoroethylene (PTFE).

5.3 Steel rule, (25 ± 1) mm, length (350 ± 1) mm of width and mass (250 ± 10) g, accurately graduated in millimetres, and with a rubber-covered underside.

NOTE 4 A rule made of steel plate 3,5 mm thick will have the correct mass.

6 Sampling

Carry out sampling in accordance with ISO 186.

7 Preparation and conditioning of test pieces

7.1 Cut out six test pieces (25 ± 1) mm \times (250 ± 1) mm with their long edges parallel to the textile manufacturing machine direction (MD) and an equal number of test pieces with their long edges in the perpendicular, or cross-machine, direction (CD). The test pieces shall be taken at least 50 mm from the edge of the fabric and the test pieces shall be handled as little as possible.

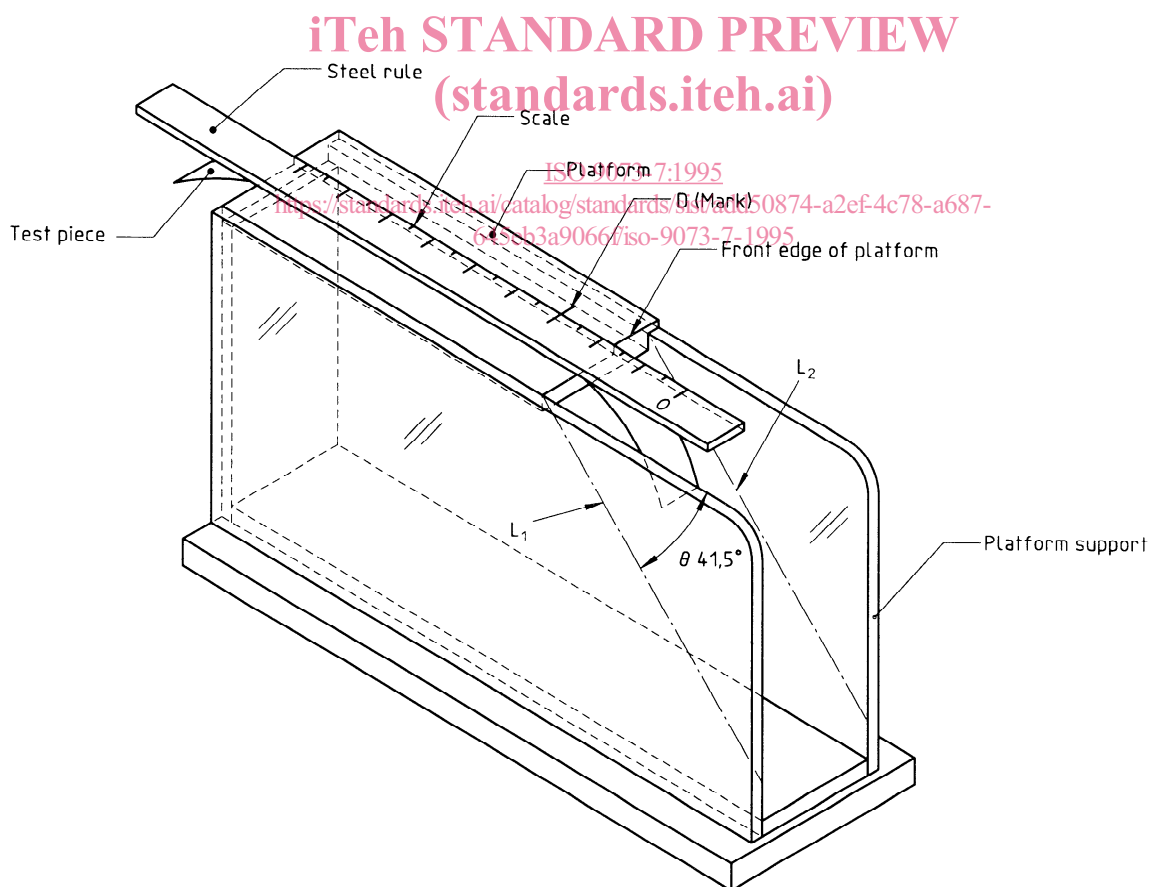

Figure 1 — Apparatus for measuring bending length

NOTES

5 Fabrics which tend to curl or twist should be conditioned before cutting out the test pieces. If the test pieces curl or twist seriously, they can often be made to lie flat long enough for testing by pressing lightly between flat surfaces for several hours.

6 Additional samples may be taken at an angle of 45° to the machine direction.

7 For production control, the number of test pieces may be limited to three in each direction (MD and CD).

7.2 Condition the test pieces and carry out the test in one of the standard atmospheres specified in ISO 139.

8 Procedure

8.1 Weigh the test piece and calculate the mass per unit area in grams per square metre in accordance with ISO 9073-1.

8.2 Place the apparatus on the level table (5.1). Place the test piece on the platform with one end coinciding with the front edge of the platform. Place the steel rule (5.3) on the test piece with the zero of the scale in line with the mark D on the platform.

Push the steel rule forward so that the test piece projects over the front edge of the platform and bends down under its own weight. Move the rule forward at a constant speed (this can be facilitated by using an apparatus fitted with a motorized drive, see note 7) until the overhanging end of the test piece reaches the two lines on the platform support L_1 and L_2 . After an interval of (8 ± 2) s, read on the scale on the steel rule the overhanging length of the test piece.

NOTE 8 Information on a suitable apparatus fitted with a motorized drive can be provided by the following associations in the nonwovens industry:

INDA, 1001 Winstead Drive, Suite 460, Cary, NC 27513, USA;

EDANA, 157 av. Eugène Plasky, B-1040 Brussels.

8.3 Repeat the operation in 8.2 with the other face of the test piece up, and again at the other end of the test piece, first with the original face up and then with the test piece turned over.

NOTE 9 It may be helpful to place the apparatus so that the zero of the scale on the rule lies towards the observer and at a level that enables the scale to be read with comfort. The position of the end of the test piece relative to L_1 and

L_2 may be observed in a mirror suitably placed or attached to one side of the apparatus.

9 Expression of results

9.1 Taking the bending length to be half the length of the overhang, record the four values of the bending length for each test piece and from these calculate the mean bending length for each test piece.

9.2 Then calculate the overall mean bending length, C , in centimetres, for the six test pieces cut in the machine direction.

Calculate the same parameter separately for the six test pieces cut in the cross-machine direction.

9.3 Calculate the mean flexural rigidity, G , per unit width, in millinewton centimetres, separately for the machine direction and the cross-machine direction test pieces, using the following equation:

$$G = m \times C^3 \times 10^{-3}$$

where

m is the mass of the test piece per unit area, in grams per square metre;

C is the overall mean bending length, in centimetres, of the test piece.

NOTE 10 In determining this equation, the acceleration due to gravity, 9,81 m/s², has been rounded to 10 m/s².

9.4 Calculate the coefficient of variation (ratio of the standard deviation to the average) for C and G in both machine direction and cross-machine direction.

10 Test report

The test report shall include the following information:

- a reference to this part of ISO 9073;
- all details necessary for the identification of the material;
- number of measurements taken;
- number of MD test pieces tested;
- number of CD test pieces tested;
- overall mean bending length and coefficient of variation of the test material for the machine direction;

- g) overall mean bending length and coefficient of variation of the test material for the cross-machine direction;
- h) mean flexural rigidity and coefficient of variation of the test material for the machine direction (MD);
- i) mean flexural rigidity and coefficient of variation of the test material for the cross-machine direction (CD);
- j) any unusual features noted during the testing, or deviations from the procedure specified in this part of ISO 9073.

iTeh STANDARD PREVIEW
(standards.iteh.ai)

ISO 9073-7:1995

<https://standards.iteh.ai/catalog/standards/sist/add50874-a2ef-4c78-a687-645eb3a9066f/iso-9073-7-1995>

Annex A (informative)

Flexural rigidity, bending length and overhanging length

A.1 Flexural rigidity can be expressed as a function of the deflection of a cantilever submitted to its own weight by the following formula (only valid for small deformations):

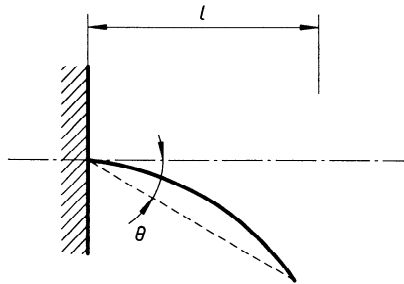

$$G = \frac{1}{\frac{\tan \theta}{\cos(0,5\theta)}} \times \frac{pl^3}{8}$$

where

- G is the flexural rigidity (per unit width);
- θ is the angular deflection of the cantilever end;
- p is the own weight per unit area (= mass per unit area \times acceleration due to gravity);
- l is the cantilever length.

A.2 For $\theta = 7,1^\circ$:

$$\frac{\tan \theta}{\cos(0,5\theta)} = \frac{1}{8}$$

Let $l = C$ (bending length)

then

$$G = pC^3 \quad \dots (A.1)$$

A.3 For ease of measurement, the method given in this part of ISO 9073 uses the cantilever length corresponding to the angular deflection $\theta = 41,5^\circ$.

For $\theta = 41,5^\circ$:

Let $l = L$ (overhanging length)

It can be shown (see note 10) that

$$G = \frac{pL^3}{8} \quad \dots (A.2)$$

On comparison with equation (A.1), we see that

$$G = \frac{pL^3}{8} = pC^3 \text{ and } C = \frac{L}{2}$$

iTeh STANDARD PREVIEW
(standards.iteh.ai)

ISO 9073-7:1995 Therefore the bending length is half the overhanging length.
<https://standards.iteh.ai/catalog/standards/sist/1156874-a2ef-4c78-a687-1166fiso-9073-7-1995>

NOTE 11 The reader is referred to the following articles:

- [1] PIERCE, F.T. "The handle of cloth as a measurable quantity". *J. Textile Inst., Trans.*, **21** (1930) T 377.
- [2] BICKLEY, W.G. "The heavy elastica". *Philosophical Magazine*, **17** (1934) pp. 603-622.

iTeh STANDARD PREVIEW (standards.iteh.ai)

ISO 9073-7:1995

<https://standards.iteh.ai/catalog/standards/sist/add50874-a2ef-4c78-a687-645eb3a9066f/iso-9073-7-1995>

ICS 59.080.30

Descriptors: textiles, fabrics, non-woven fabrics, tests, bend tests, determination, length.

Price based on 5 pages
