



Standard Test Method for Fire Testing of Upholstered Furniture¹

This standard is issued under the fixed designation E 1537; the number immediately following the designation indicates the year of original adoption or, in the case of revision, the year of last revision. A number in parentheses indicates the year of last reappraisal. A superscript epsilon (ϵ) indicates an editorial change since the last revision or reappraisal.

1. Scope

1.1 This is a fire-test-response standard.

1.2 The purpose of this test method is to determine the burning behavior of upholstered furniture used in public occupancies by measuring specific fire-test responses when the specimen of furniture is subjected to a specified flaming ignition source under well-ventilated conditions.

1.3 Data are obtained describing the burning behavior from a specific ignition source until all burning has ceased, a period of 1 h has elapsed, or flashover appears inevitable.

1.4 This test method does not provide information on the fire performance of upholstered furniture in fire conditions other than those conditions specified. In particular, this test method does not apply to smoldering ignition by cigarettes. See X1.6 for further information.

1.5 The rate of heat release of the burning specimen is measured by an oxygen consumption method. See X1.6.4 for further information.

1.6 The production of light obscuring smoke is measured and the concentrations of certain toxic gas species in the combustion gases are determined. See X1.6.5 for further information.

1.7 The burning behavior is visually documented by photographic or video recordings, whenever possible.

1.8 The system of units to be used in referee decisions is the SI system of units, see Practice E 380 only. The units given in parentheses are for information only.

1.9 *This standard is used to measure and describe the response of materials, products, or assemblies to heat and flame under controlled conditions, but does not by itself incorporate all factors required for fire hazard or fire risk assessment of the materials, products or assemblies under actual fire conditions.*

1.10 *Fire testing of products and materials is inherently hazardous, and adequate safeguards for personnel and property shall be employed in conducting these tests. This test method may involve hazardous materials, operations, and equipment.*

1.11 *This standard does not purport to address all of the safety concerns, if any, associated with its use. It is the*

responsibility of the user of this standard to establish appropriate safety and health practices and determine the applicability of regulatory limitations prior to use.

2. Referenced Documents

2.1 ASTM Standards:

- D 123 Terminology Relating to Textiles²
- E 84 Test Method for Surface Burning Characteristics of Building Materials³
- E 176 Terminology of Fire Standards³
- E 380 Practice for Use of the International System of Units (SI) (the Modernized Metric System)⁴
- E 800 Guide for Measurement of Gases Present or Generated During Fires³
- E 1354 Test Method for Heat and Visible Smoke Release Rates for Materials and Products Using an Oxygen Consumption Calorimeter³

2.2 ISO Standards:

- ISO 3261 Fire Tests—Vocabulary⁵
- ISO 4880 Burning Behaviour of Textiles and Textile Products—Vocabulary⁵
- ISO 9705 Fire Tests—Full Scale Room Test for Surface Products⁵

2.3 UL Standard:

- UL 1056 Fire Test of Upholstered Furniture⁶

2.4 CA Standard:

- CA Technical Bulletin 133 Flammability Test Procedure for Seating Furniture for Use in Public Occupancies⁷

2.5 BSI Standard:

- BS 5852: Part 2: Fire Tests for Furniture, Part 2. Methods of Test for the Ignitability of Upholstered Composites for Seating by Flame Sources⁸

2.6 Nordtest Standard:

- Nordtest Method NT Fire 032 Upholstered Furniture: Burning Behavior—Full Scale Test⁹

² Annual Book of ASTM Standards, Vol 07.01.

³ Annual Book of ASTM Standards, Vol 04.07.

⁴ Annual Book of ASTM Standards, Vol 14.02.

⁵ Available from American National Standards Institute, 11 West 42nd Street, 13th Floor, New York, NY 10036.

⁶ Available from Underwriters Laboratories, 333 Pfingsten Road, Northbrook, IL 60062.

⁷ Available from State of California, Department of Consumer Affairs, 3485 Orange Grove Avenue, North Highlands, CA 95660.

⁸ Available from British Standards Institution, 2 Park St., London W1A 2B5, UK.

⁹ Available from Nordtest, PO Box 22, SF-00341, Helsingfors, Finland.

¹ This test method is under the jurisdiction of ASTM Committee E-5 on Fire Standards and is the direct responsibility of Subcommittee E05.15 on Furnishing and Contents.

Current edition approved Feb. 10, 1999. Published July 1999. Originally published as E 1537 – 93. Last previous edition E 1537 – 98^{E1}.

3. Terminology

3.1 Definitions:

3.1.1 For definitions of terms used in this test method and associated with fire issues, refer to the terminology contained in Terminology E 176 and in ISO 3261.

3.1.2 For definitions of terms used in this test method and associated with textile issues refer to the terminology contained in Terminology D 123.

3.2 Definitions of Terms Specific to This Standard:

3.2.1 *product, n*—the upholstered furniture for which information is required.

3.2.2 *specimen, n*—manufactured item of the product, representative prototype of the product, or mock-up of the product.

3.2.2.1 *Discussion*—The mock-up shall be constructed as described in Annex A1.

3.2.3 *upholstered, adj*—covered with material (as fabric or padding) to provide a soft surface.

3.2.4 *upholstered seating furniture, n*—a unit of interior furnishing that (1) contains any surface that is covered, in whole or in part, with a fabric or other upholstery cover material, (2) contains upholstery material, and (3) is intended or promoted for sitting upon.

3.2.5 *upholstery cover material, n*—the outermost layer of fabric or related materials used to enclose the main support system, or upholstery materials, or both, used in the furniture unit.

3.2.6 *upholstery material, n*—the padding, stuffing, or filling material used in a furniture unit, which may be either loose or attached, enclosed by an upholstery cover material, or located between the upholstery cover material and support system, if present.

4. Summary of Test Method

4.1 This test method determines a number of fire-test-response characteristics from a full-scale specimen of upholstered furniture ignited with a propane gas burner. Measurements to be made include rate of heat and smoke release, total amount of heat and smoke released, rate and concentration of carbon oxides released, and rate and amount of mass of specimen lost. Other optional measurements are also described.

4.2 Three options are provided, in all of which the upholstered furniture specimen to be tested is placed on a weighing platform and measurements of heat release, smoke release, and combustion gas release are made in an exhaust duct.

4.3 In Options A and B the duct is located outside the doorway of a test room. In Option C the duct is located directly over the specimen.

4.4 Additional (optional) instrumentation placed in the test room is also described.

5. Significance and Use

5.1 This test method provides a means to measure a variety of fire-test-response characteristics resulting from burning a specimen of upholstered furniture. The upholstered furniture specimen is allowed to burn freely under well-ventilated conditions after ignition using a propane gas burner. The most important fire-test-response characteristic measured is the rate

of heat release, which quantifies the intensity of the fire generated.

5.2 The rate of heat release is measured by the principle of oxygen consumption. The assumptions and limitations of oxygen depletion calorimetry are discussed in Annex A4, and in particular in A4.1.2.

5.3 Other fire-test-response characteristics are measured, namely smoke obscuration and combustion gas release, as they are also important in making decisions on fire safety.

5.4 The most important gaseous components of smoke are the carbon oxides, present in all fires. They are indicators of the toxicity of the atmosphere and of the completeness of combustion. Measurement of concentrations of carbon oxides are useful for two purposes: as part of fire hazard assessment calculations and to improve the accuracy of heat release measurements. Other toxic combustion gases, which are specific to certain materials, are less crucial for determining combustion completeness and are optional measures, but fire hazard assessment often requires their measurement.

5.5 The type of ignition chosen (a flaming source) is common in both accidental and intentional fires in public occupancies. This test method is thus applicable to upholstered furniture in public occupancies. Such facilities include, but are not limited to, jails, prisons, nursing care homes, health care facilities, public auditoriums, hotels, and motels.

5.6 It has been shown that if the gas burner is used at a flow rate of 13 L/min for 80 s (equivalent to 19.3 kW), as is the case in California Technical Bulletin (CA TB) 133, it approximates the ignition propensity of five crumpled sheets of newspaper located on the seating cushion.

5.7 This test method specifies both a particular flow rate of propane gas and a period of gas flow. If the ignition conditions are changed, the results would then deviate from the model selected for this test.

5.8 This test method is not applicable to ignition of upholstered furniture by cigarettes.

5.9 One of the following three test configurations is to be used in this test method:

5.9.1 *A*—A test room with the following dimensions: 3.66 by 2.44 by 2.44 m high.

5.9.2 *B*—A test room with the following dimensions: 3.66 by 3.05 by 2.44 m high.

5.9.3 *C*—An open calorimeter (or furniture calorimeter).

5.10 Measurements in the three test configurations listed in 5.9 have been shown to give similar results for heat release in the duct, for heat release rates lower than 600 kW (see X1.4) (1).¹⁰

5.11 Measurements of temperatures, gas concentrations, and smoke obscuration in the room, which are optional in this test method, are dependent on room size.

5.12 This test method has been designed to give details for the means to build and operate equipment capable of running tests as required by CA TB 133. This test method is, however, more general than that technical bulletin.

¹⁰ The boldface numbers in parentheses refer to a list of references at the end of the text.

6. Test Specimen

6.1 The test specimen consists of a full-size manufactured item of upholstered furniture, a representative prototype of the upholstered furniture, or a mock-up of the upholstered furniture, constructed in accordance with Annex A1.

6.2 When a full-scale upholstered furniture mock-up is used, the mock-up shall in all possible respects reflect the construction of the actual furniture that it is intended to represent.

7. Room Layout and Instrumentation

7.1 *Test Room Layout (Test Configuration A)*—The test room shall have dimensions of 2.44 m ± 25 mm by 3.66 m ± 25 mm by 2.44 m ± 25 mm high (8 by 12 by 8 ft high). The room shall have no openings other than a doorway opening 0.76 m ± 6.4 mm by 2.03 m ± 6.4 mm (30 by 80 in.), located as indicated in Fig. 1, and other small openings, as necessary to make test measurements. Construct the test room of wooden or metal studs, and line it with fire rated gypsum wallboard or calcium silicate wallboard. Position a hood, as described in Annex A2, outside of the room doorway, such that it collects all the combustion gases. There shall be no obstructions to the air supply to the test setup.

board with a thickness of at least 13 mm (0.5 in.) have been found acceptable. If the thickness of the wallboard is larger, it will not affect the results of this test.

7.2 *Test Room Layout (Test Configuration B)*—The test room shall have dimensions of 3.05 m ± 25 mm by 3.66 m ± 25 mm by 2.44 m ± 25 mm high (10 by 12 by 8 ft high). The room shall have no openings other than a doorway opening 0.97 m ± 6.4 mm by 2.06 m ± 6.4 mm (38 by 81 in.), located as indicated in Fig. 2, and other small openings, as necessary, to make test measurements. Construct the test room of wooden or metal studs, and line it with fire-rated gypsum wallboard or calcium silicate wallboard. Position a hood, as described in Annex A2, outside of the room doorway, such that it collects all the combustion gases. There shall be no obstructions to the air supply to the test set-up. (See Note 1.)

7.3 *Open Calorimeter Layout (Test Configuration C)*—The area surrounding the test specimen shall be sufficiently large that there are no heat radiation effects from the walls or any other nearby objects. The airflow to the test specimen shall be symmetrical from all sides.

7.4 *General Discussion of Room Layout*—Heat release measurements in the duct, made in Options A, B, and C have

NOTE 1—Both Type X gypsum wallboard and calcium silicate wall-

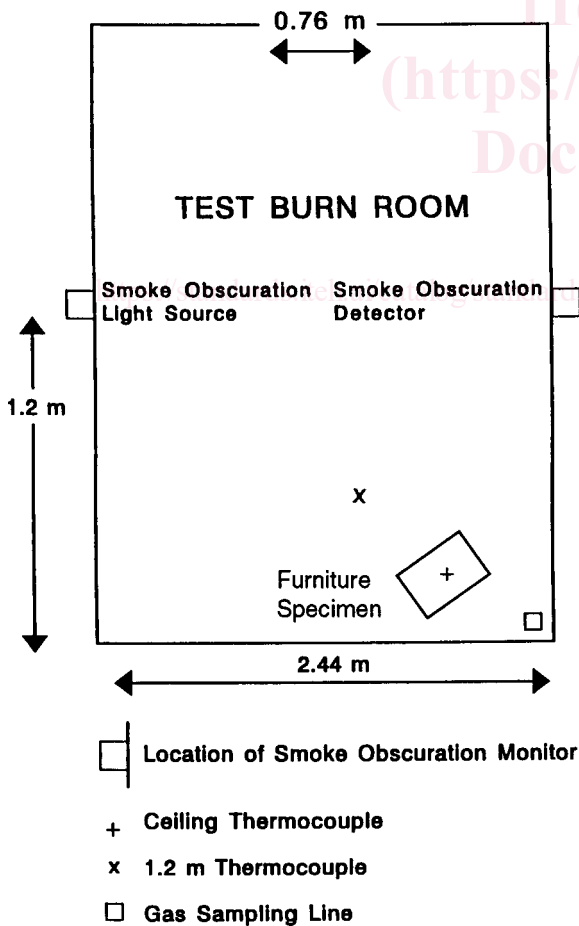

NOTE 1—See text for tolerances; room instrumentation is optional.
FIG. 1 Test Room Configuration for Option A for Items of Furniture Less Than 1 m Across

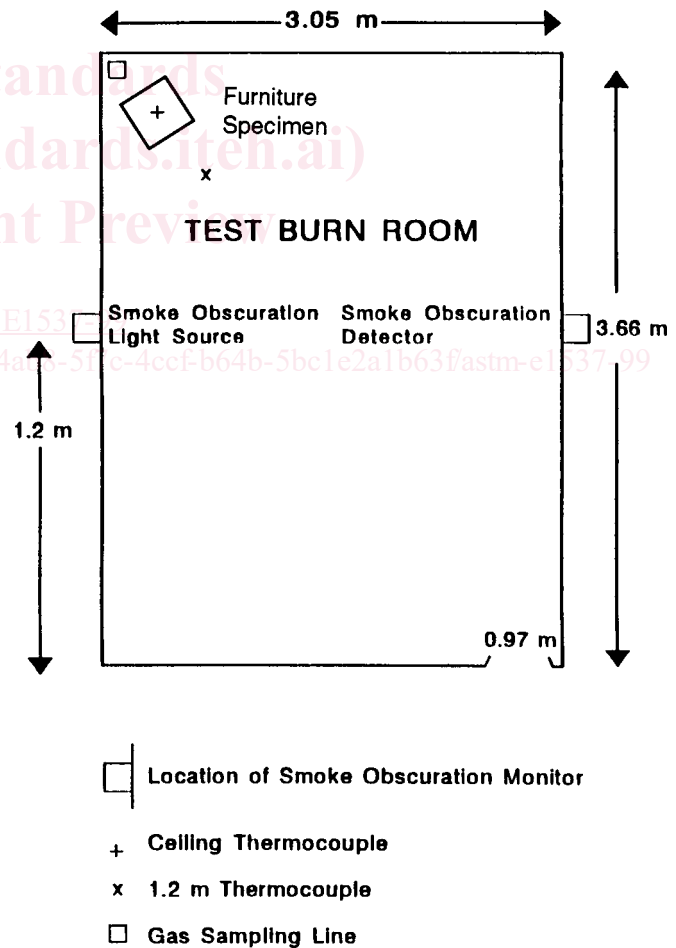

NOTE 1—See text for tolerances; room instrumentation is optional.
FIG. 2 Test Room Configuration for Option B for Items of Furniture Less Than 1 m Across

been shown to give similar results for heat release rates lower than 600 kW (see X1.4) (1).

7.5 *Other Test Room Furnishings*—The test room shall contain no furnishings except for the item to be tested.

7.6 *Test Room Instrumentation (Optional)*:

7.6.1 Location of optional test room instruments is described in Figs. 1-4.

7.6.2 Carry out optional room temperature measurements with chromel-alumel Type K thermocouples, shielded against high heat with insulation resisting up to 1200°C. Use a wire gage in the range of 24 to 30 AWG (0.51 to 0.36 mm) diameter, and mount the thermocouples in two test locations:

7.6.2.1 Over the geometric center of the igniter, 25 mm (1 in.) below the ceiling (ceiling thermocouple), and

7.6.2.2 At a distance of 0.91 m (3 ft) in front of the center of the igniter, away from the furniture specimen, and 1.22 m (4 ft) below the ceiling.

7.6.3 Carry out optional optical density of smoke measurements with a smoke obscuration monitor, placed at a height of 1.22 m (4 ft) above the floor level. A white light or laser photometer system similar to that described for the duct is also suitable (see 8.2.4 or Annex A3).

7.6.4 Carry out optional carbon monoxide concentration measurements with a gas sampling line located 165 mm (6.5 in.) below the ceiling and 165 mm (6.5 in.) from each wall of the corner where the specimen is placed.

7.7 *Location of Specimen*:

7.7.1 *Test Configurations A or B*:

7.7.1.1 Position the furniture specimen on a weighing plat-

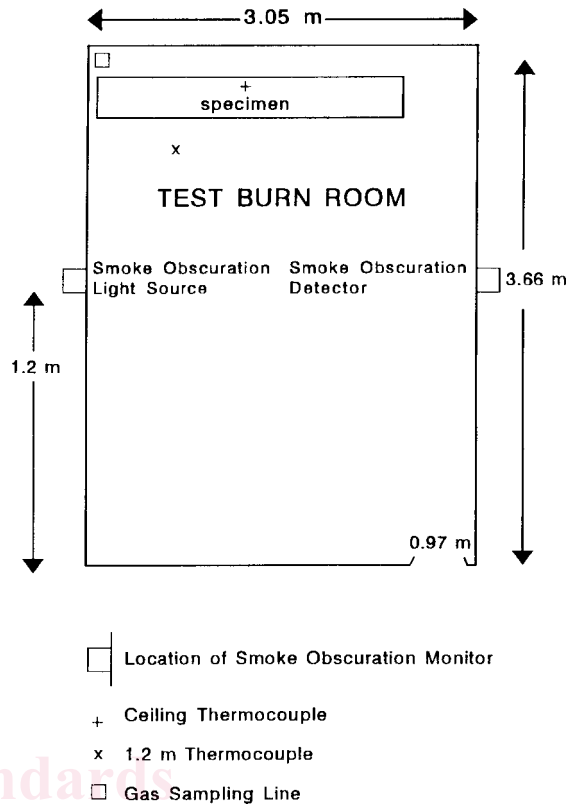

NOTE 1—See text for tolerances; room instrumentation is optional.

FIG. 4 Test Room Configuration for Option B for Items of Furniture Between 1 and 2.44 m Across

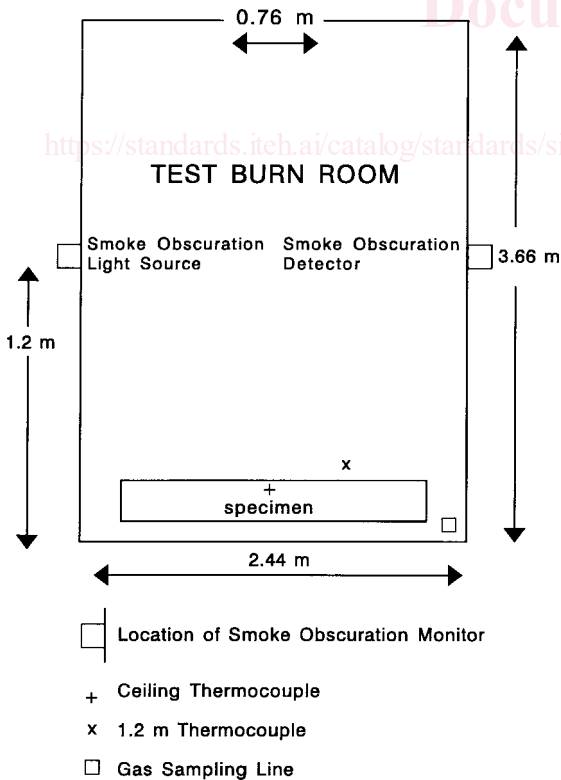

NOTE 1—See text for tolerances; room instrumentation is optional.

FIG. 3 Test Room Configuration for Option A for Items of Furniture Between 1 and 2.44 m Across

form in a corner so that the furniture is at a distance of between 0.10 and 0.25 m (4 and 10 in.) from both walls.

7.7.1.2 The location for the furniture specimen is such that it faces the wall containing the doorway, with the preferred location at the greatest distance from the doorway.

7.7.1.3 If the furniture specimen is no more than 1.0 m (40 in.) in width, refer to Fig. 1 or 2 for the furniture specimen location. If the furniture specimen is more than 1.0 m (40 in.) in width, refer to Fig. 3 or Fig. 4.

7.7.1.4 These test configurations shall not be used to test furniture specimens that are more than 2.44 m (8 ft) in length.

7.7.2 *Test Configuration C*:

7.7.2.1 Position the furniture specimen on a weighing platform underneath the hood.

7.7.2.2 This test method, in Test Configuration C, is suitable for furniture specimens more than 2.44 m (8 ft) in length only if the hood is large enough to collect all the smoke generated.

7.8 *Ignition Source*:

7.8.1 Use a square gas burner, as described in Figs. 5 and 6, and Fig. 7.

7.8.2 Construct the 250 ± 10 by 250 ± 10 mm (approximately 10 by 10 in.) square burner of 13 ± 1 mm (0.5 in.) outside diameter stainless steel tubing, with 0.89 ± 0.05 mm (0.035 in.) wall thickness (see Fig. 5). The front side shall have 14 holes pointing straight out and spaced 13 ± 1 mm (0.5 in.) apart and nine holes pointing straight down and spaced 13 ± 1 mm (0.5 in.) apart. The right and left sides shall have six holes pointing straight out and spaced 13 ± 1 mm (0.5 in.) apart and

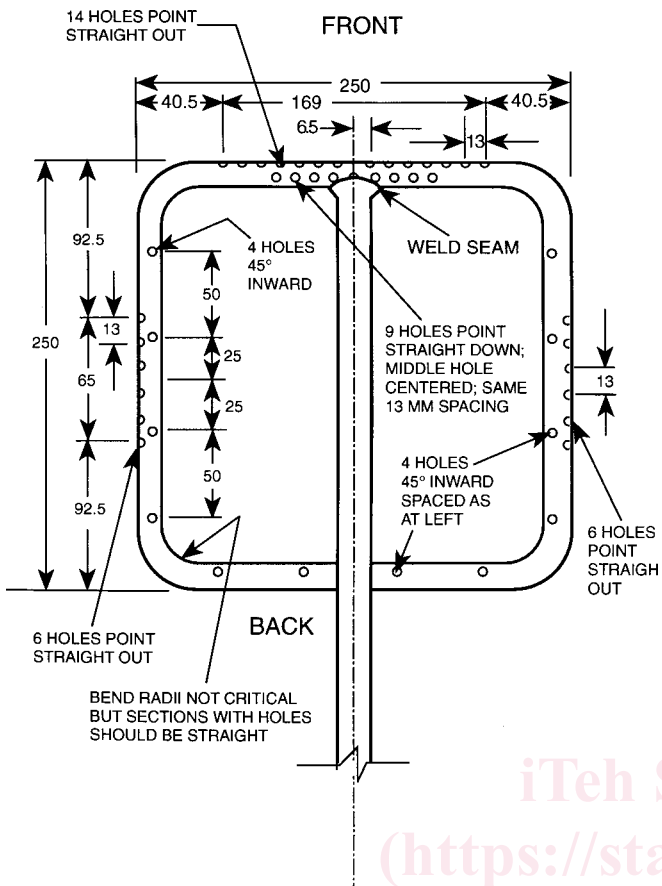

NOTE 1—All tubing 13 mm outside diameter, stainless steel, 0.89 mm wall thickness.

NOTE 2—All holes 1 mm in diameter.

NOTE 3—All units are mm unless otherwise noted.

NOTE 4—See text for tolerances.

FIG. 5 Plan View of Square Gas Burner

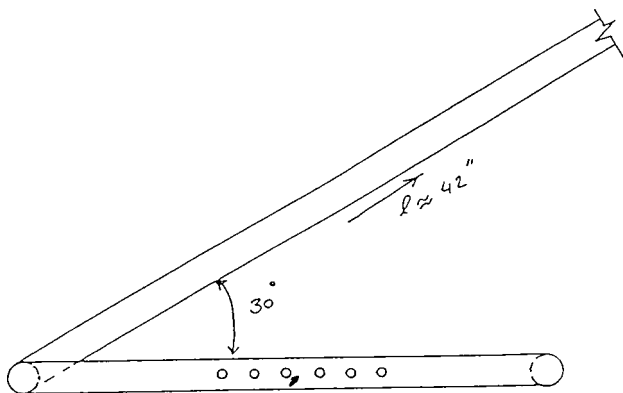

FIG. 6 Side View of Square Gas Burner

four holes pointing inward at a 45° angle and spaced 50 ± 2 mm (2 in.) apart. All holes shall be of 1 ± 0.05 mm (0.039 in.) diameter (see Fig. 5, Fig. 6, and Fig. 7). The straight arm of the burner shall be 1.07 ± 0.05 m (42 in.) long and welded on to the rear of the front side (see Fig. 5) at a 30° angle. Mount the burner on an adjustable height pole at a height of 460 ± 13 mm (18 ± 0.5 in.) and balance it by a counterweight or other appropriate mechanism (see Fig. 8).

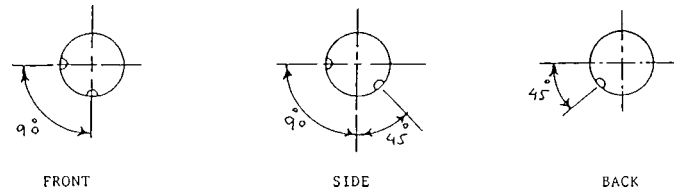
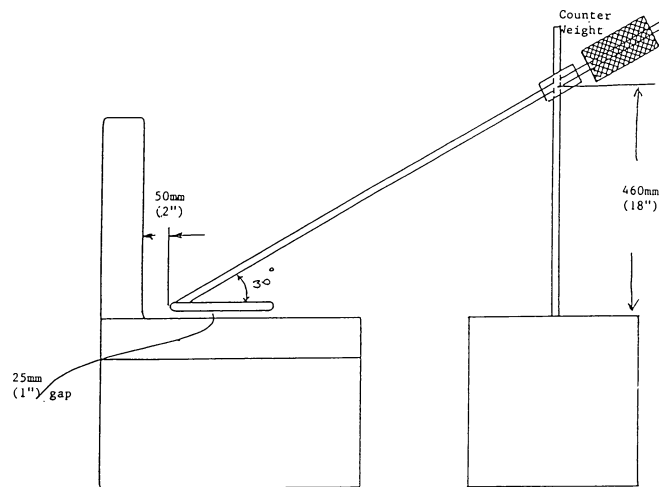

FIG. 7 Cross-sectional View of Each Side of Square Gas Burner



NOTE 1—See text for tolerances.

FIG. 8 Positioning of Square Gas Burner on a Chair

NOTE 2—**Caution:** It is common for the burner holes to become clogged up following a test. Inspect burner holes after each test, and clean thoroughly, if required. Take care not to enlarge the holes when cleaning them.

7.8.3 The burner is described in detail in Ref. (2).

7.8.4 Use propane gas, with a known net heat of combustion of 2050 ± 50 kJ/mol, as a fuel for this ignition source. Meter the flow rate of propane and keep it constant throughout the test.

7.8.5 Use the gas burner at a flow rate of 13 ± 0.25 L/min for a total of 80 s. Measure the gas flow rate at a pressure of 101 ± 5 kPa (standard atmospheric pressure, measured at the flow gage) and a temperature of 20 ± 5°C. The approximate ratio of heat release rate output to gas flow rate is 1.485 kW min/L, under standard conditions.

7.9 Location of Gas Burner:

7.9.1 If the furniture specimen is less than 1.0 m wide (overall), place the gas burner at the center of the furniture seating surface, 50 ± 5 mm (2 ± 0.2 in.) away from the furniture back and 25 ± 5 mm (1 ± 0.2 in.) above the seating surface.

7.9.2 Test any specimen over 1.0 m wide with the gas burner located at 125 ± 10 mm (5 ± 0.4 in.) from the side of the piece of furniture, 50 ± 5 mm (2 ± 0.2 in.) away from the furniture back and 25 ± 5 mm (1 ± 0.2 in.) above the seating surface.

7.9.3 In order to facilitate repeatability and reproducibility, it has been found useful to determine the exact location of the gas burner on the furniture by using a back line marker gage.

7.10 Mass Loss Measurements:

7.10.1 Use a weighing platform to continuously measure the mass of the burning specimen. Construct a weighing platform,

consisting of a horizontal thermal barrier, as described in 7.10.2 and 7.10.3, and placed on top of a mass measuring device.

7.10.2 Construct a thermal barrier large enough to prevent melting or falling material from the tested furniture specimen from falling off the thermal barrier. The barrier shall be used to protect the load cell.

7.10.3 The barrier shall consist of a galvanized steel pan with gypsum board lining placed under the furniture specimen. The pan shall be constructed of nominally 1.6-mm (1/16 in.) thick steel, and have dimensions of no less than 1.0 by 1.0 m (which corresponds to approximately 39 by 39 in.), with a uniform raised lip of the same material, 100 ± 10 mm (approximately 4 in.) high, on each side, to catch falling material. The bottom of the pan shall be covered by a tight fitting section of standard gypsum board (finish side up), of nominally 13 mm (0.5 in.) thickness. The gypsum board shall be clean before the start of a test; the board shall be replaced for each test. Pans with dimensions of 1.2 ± 0.1 by 2.1 ± 0.1 m (4 ft ± 4 in. by 8 ft ± 4 in.) have been found satisfactory for testing large furniture specimens.

7.10.4 Measure the specimen mass continuously with a device capable of an accuracy of no less than ±150 g, up to at least 90 kg. Install it in such a way that neither the heat from the burning specimen nor any eccentricity of the load affect the accuracy. Do not make any range shifts during measurements. Install all parts of the mass measuring device below the top level of the thermal barrier.

7.10.5 The distance from the upper surface of the thermal barrier to floor level shall not exceed 0.5 m (20 in.). The area between the thermal barrier and the floor level shall be shielded in order to avoid lifting forces, due to fire induced air flow, that influence the measurement.

8. Exhaust Collection System

8.1 General:

8.1.1 The exhaust collection system shall consist of a blower, steel hood, duct, bidirectional probe, thermocouple(s), oxygen measurement system, smoke obscuration measuring system (white light photocell lamp/detector or laser), and combustion gas sampling and analysis system. It shall be constructed as shown in Fig. A2.1 and as explained in Annex A2.

8.1.2 The system for collecting the combustion products shall have a capacity and be designed in such a way that all of the combustion products leaving the burning specimen are collected. Design the capacity of the evacuation system so as to exhaust all combustion gases leaving the furniture specimen (see A2.1.4).

8.1.3 Place probes for sampling of combustion gas and for measurement of flow rate in accordance with 8.2.

8.1.4 Measure all combustion product (smoke obscuration and gas concentrations) at a position in the exhaust duct where the exhaust is uniformly mixed and there is a nearly uniform velocity across the duct section. A distance of 10 to 30 duct diameters is satisfactory for this purpose.

8.2 Details of Instrumentation in Exhaust Duct:

8.2.1 The following specifications are minimum requirements for exhaust duct instrumentation. Additional information

is found in Annex A3.

8.2.2 *Flow Rate*—Measure the flow rate in the exhaust duct by means of a bidirectional probe located at the center line of the duct (see A3.1 for further details). Measure the flow rate in the exhaust duct with an accuracy of at least ±6 %. The response time to a stepwise change of the duct flow rate shall be a maximum of 5 s to reach 90 % of the final value.

8.2.3 Combustion Gas Analysis:

8.2.3.1 *Sampling Line*— Make the sampling line tubes of a material not influencing the concentration of the combustion gas species to be analyzed. The recommended sequence of the gas train is: sampling probe, soot filter, cold trap, gas path pump, vent valve, plastic drying column and carbon dioxide removal columns (if used), flow controller and oxygen analyzer (see Fig. 9 and A3.2 for further details). The gas train shall also include appropriate spanning and zeroing facilities.

8.2.3.2 *Oxygen Measurement*—Measure the oxygen concentration with an accuracy of at least ±0.04 % of full scale in the output range of 0 to 21 vol % oxygen, or ±0.01 vol % oxygen, in order to have adequate measurements of rate of heat release. Take the combustion gas sample from the end of the sampling line. Calculate the time delay, including the time constant of the instrument, from the test room; it is a function of the exhaust duct flow rate. It shall be a maximum of 30 s. (See A3.3 for further details.) A discussion of the calculations for rate of heat release is given in Annex A4.

8.2.3.3 *Carbon Monoxide and Carbon Dioxide Measurement*—Measure the combustion gas species with an instrument having an accuracy of at least ±0.1 vol % for carbon dioxide and ±0.02 vol % for carbon monoxide. A suitable output range is 0 to 1 vol % for carbon monoxide and 0 to 6 vol % for carbon dioxide. Take the combustion gas sample from the end of the sampling line. Calculate the time delay, including the time constant of the instrument, from the test room; it is a function of the exhaust duct flow rate. It shall be a maximum of 30 s. (See A3.3 for further details.)

8.2.4 *Smoke Obscuration Measurement*—Install an optical system for measurement of light obscuration across the centerline of the exhaust duct. Determine the optical density of the smoke by measuring the light transmitted with a photometer system consisting of a lamp, plano convex lenses, an aperture, a photocell, and an appropriate power supply. See Fig. 10 and A3.4 for further details. Construct the system so that soot deposits on the optics during a test do not reduce the light transmission by more than 5 %. Alternatively, instrumentation using a laser beam system, with an 0.5 to 2.0 mW helium-neon laser, instead of white light system is also acceptable. See Fig.

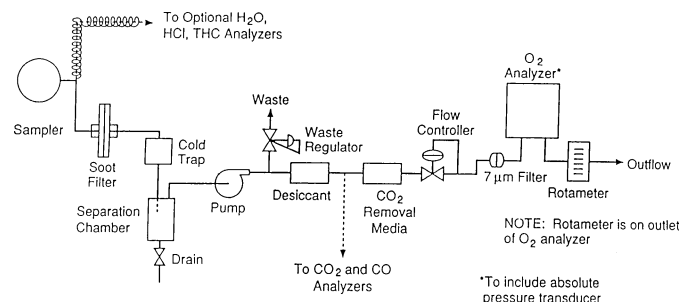

FIG. 9 Schematic of Gas Train

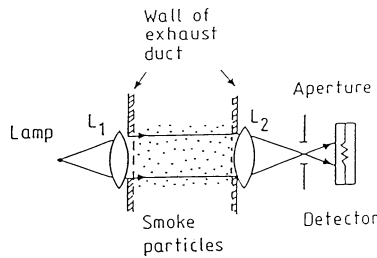
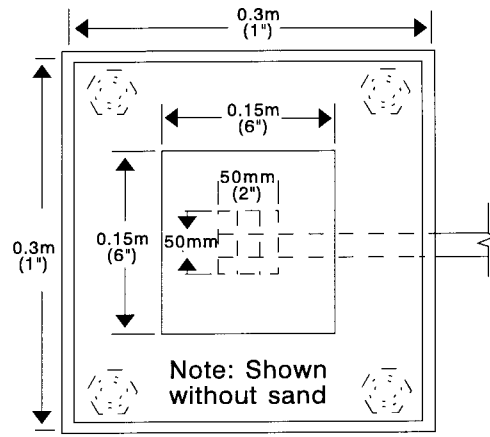
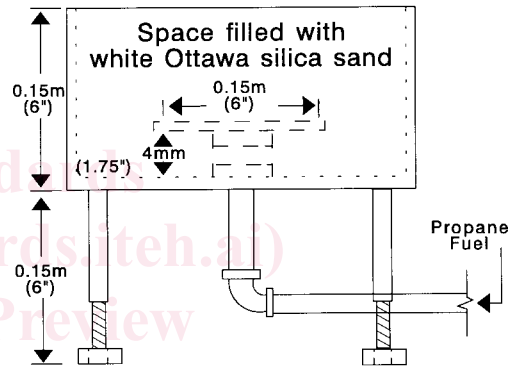

FIG. 10 Optical System, Using a White Light



Plan View



Elevation

NOTE 1—See text for tolerances.

FIG. 12 Calibration Gas Burner

11 and A3.4 for further details. It has been shown that white light and laser systems will give similar results (see Refs (3-6)).

9. Calibration

9.1 Calibrate all instruments carefully with standard sources after initial installation. Among the instruments to be calibrated are load cells or weighing platforms, smoke meters, flow or velocity transducers, and gas analyzers. Perform recalibration tests on the entire system, for example, using standard output burners.

9.2 Heat Release:

9.2.1 Perform the calibration of the heat release instrumentation in the exhaust duct by burning propane or methane gas and comparing the heat release rates calculated from the metered gas input and those calculated from the measured oxygen consumption. The value of net heat of combustion for methane is 50.0 MJ/kg and that for propane is 46.5 MJ/kg. Position the burner in the same location where the upholstered furniture specimen is to be placed during the test. Measure the gas flow rate at a pressure of 10 ± 5 kPa (standard atmospheric pressure, measured at the flow gage) and a temperature of $20 \pm 5^\circ\text{C}$.

9.2.2 A suitable calibration burner is a sand diffusion burner with a 0.3 by 0.3-m (12 by 12-in.) top surface and a 0.15-m (6-in.) depth. Construct such a gas burner with a 25 mm (1 in.) thick plenum. Alternatively, use a minimum 100 mm (4 in.) layer of Ottawa sand to provide the horizontal surface through which the gas is supplied. This type of burner is shown in Fig. 12. The gas supply to the burner shall be propane, of the same

quality as that used for the ignition burner, or methane. The gas for the burner flame shall not be premixed with air. Meter the flow rate of gas and keep it constant throughout the calibration test.

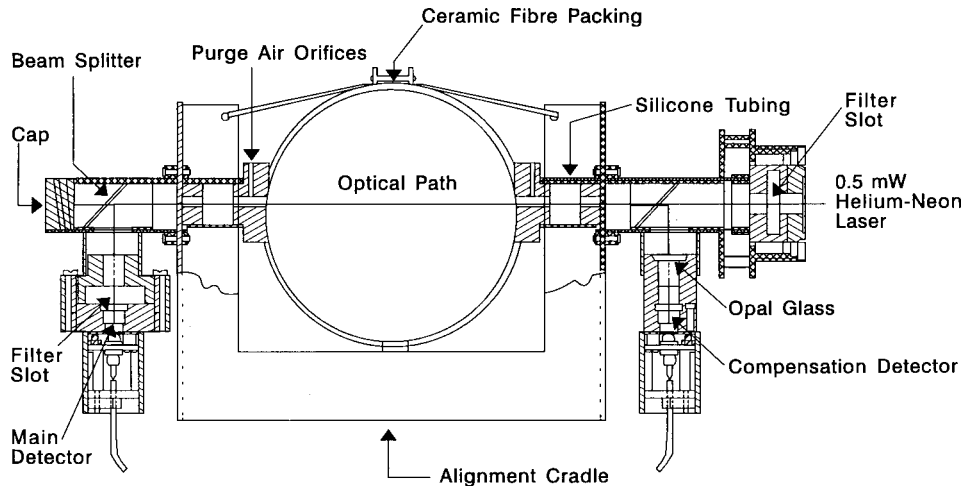

FIG. 11 Laser Extinction Beam

9.2.3 Another suitable calibration burner is a pipe, with an inner diameter of 100 ± 1.5 mm (4 in.), supplied with gas from beneath (see ISO 9705). The gas for the burner flame shall not be premixed with air.

9.2.4 Obtain a minimum of two calibration points. Obtain a lower heat release rate value of 40 kW and then a higher heat release rate value of 160 kW. Approximate propane flow rates for any required heat release rate value are estimated using the following constant: 1.485 kW min/L, determined at a pressure of 101 ± 5 kPa (standard atmospheric pressure, measured at the flow gage) and a temperature of $20 \pm 5^\circ\text{C}$. Accurate flow rates of propane gas are calculated using the mass flow rate (Eq A5.1 or Eq A5.2).

9.2.5 Take measurements at least once every 6 s and start 1 min prior to ignition of the burner. Determine the average rate of heat release over a period of at least 1 min by the oxygen consumption method and calculating the heat release rate from the gas mass flow rate and the net heat of combustion. The difference between the two values shall not exceed 5 %. Make this comparison only after steady state conditions have been reached.

9.2.6 Perform a calibration test according to 9.5 prior to each continuous test series. Perform a full basic calibration on a new system or when modifications are introduced.

9.2.7 When calibrating a new system, or when modifications are introduced, it is recommended to check the response time of the measuring system by the following test sequence:

Time, min	Burner Output, kW
0 to 5	0
5 to 10	40
10 to 15	160
15 to 20	0

Take measurements at least once every 6 s. The response of the system to a stepwise change of the heat output from the burner shall be a maximum of 12 s to 90 % of final value.

9.2.8 Check the precision of the system at various flow rates by increasing the flow in the exhaust duct in four steps, starting from $0.25 \text{ m}^3\text{s}^{-1}$ (at 0.1 MPa and 25°C) up to maximum. The recommended heat output from the burner is 160 kW. The change in measured rate of heat release, comparing time average values over 1 min, shall not be more than 10 % of the actual heat output from the burner.

9.2.9 The use of a higher rate of heat release for calibration, for example 500 kW, will generally lead to higher accuracy in test results.

9.3 *Mass Loss*—Perform calibration of the mass measuring device by loading the weighing platform with known masses corresponding to the measuring range of interest, to ensure that the requirements of accuracy in 7.10.3 are fulfilled. Carry out this calibration daily, prior to testing.

9.4 *Smoke Obscuration*—Calibrate the smoke meter initially to read correctly for two neutral density filters of significantly different values and also at 100 % transmission. Once this calibration is set, only the zero value of extinction coefficient (100 % transmission) needs to be verified each day, prior to testing. Investigate any excessive departure from the zero line at the end of a test, and correct it.

9.5 *Gas Analysis*—Calibrate gas analyzers daily, prior to testing (see Guide E 800 for further guidance).

10. Conditioning

10.1 Prior to testing, condition the specimen for at least 48 h in an atmosphere at a temperature of $21 \pm 3^\circ\text{C}$ ($70 \pm 5^\circ\text{F}$) and a relative humidity of less than 55 ± 5 %. Test specimens within 10 min of removal from such conditions if test room conditions differ from the above.

11. Procedure

11.1 Initial Conditions:

11.1.1 The ambient temperature shall be above 15°C (60°F) and the relative humidity shall be less than 75 %.

11.1.2 The horizontal air flow, measured at the surface and at a horizontal distance of 0.5 m (20 in.) from the edge of the weighing platform, shall not exceed 0.5 ms^{-1} .

11.1.3 Position the specimen to be tested centrally on the weighing platform.

11.1.4 Have available means for extinguishing a fully developed fire.

11.2 Test Procedure:

11.2.1 Place the square gas burner above the seat cushion, as specified in 7.9.

11.2.2 Start all recording and measuring devices 2 min before starting the ignition burner.

11.2.3 Light the ignition burner.

11.2.4 Expose the specimen to the gas burner flames for 80 s, at a flow rate of 13 L/min, determine at a pressure of 101 ± 5 kPa (standard atmospheric pressure, measured at the flow gage) and a temperature of $20 \pm 5^\circ\text{C}$.

11.2.5 After the specified burning period extinguish the gas flame and remove the burner.

11.2.6 Perform a photographic or a video recording before and during each test. A clock shall appear in all photographic records, giving time to the nearest 1 s.

11.2.7 During the test record the following events and the time when they occur, with respect to the time of ignition of the burner:

11.2.7.1 Ignition of the specimen,

11.2.7.2 Position of flame front,

11.2.7.3 Melting and dripping,

11.2.7.4 Occurrence of pool fire under the specimen,

11.2.7.5 General description of the burning behavior, and

11.2.7.6 Any other event of special interest.

11.2.8 Terminate the test after the first of:

11.2.8.1 Burning has ceased,

11.2.8.2 One hour of testing has elapsed, or

11.2.8.3 Flashover appears inevitable.

11.2.9 Note, from visual inspection of the specimen after the test, the approximate percentage of each surface that was burned or charred, and the approximate depth of fire damage.

12. Calculation

12.1 Considerations for heat release measurements are presented in Annex A4. Calculate heat release data, using the equations presented in A5.1. The testing laboratory shall choose one of the equations in Annex A5 to calculate heat release.

12.2 Calculate smoke release data using the equations presented in A5.2.

12.3 Calculate gas yield data using the equations presented in A5.3.

13. Test Report

13.1 Report the following information:

13.1.1 *Descriptive Information:*

13.1.1.1 Name and address of the testing laboratory,

13.1.1.2 Date and identification number of the report,

13.1.1.3 Name and address of the test requester,

13.1.1.4 Test option used: A, B or C,

13.1.1.5 Name of product manufacturer or supplier, if known,

13.1.1.6 Name or other identification marks and description of the product,

13.1.1.7 Density, or mass per unit surface area, total mass, thickness of the main components in the specimen, and mass of combustible portion of specimen, if known,

13.1.1.8 Description of the specimen, if different from the product,

13.1.1.9 Conditioning of the specimens,

13.1.1.10 Date of test, and

13.1.1.11 Test number and any special remarks.

13.2 *Test Results* (see also Annex A1):

13.2.1 *Table of Numerical Results Containing:*

13.2.1.1 Peak rate of heat release (in kW) and the time at which it occurred,

13.2.1.2 Total heat released (in MJ),

13.2.1.3 Peak rate of smoke release (in m^2s^{-1}) and the time at which it occurred,

13.2.1.4 Total smoke released (in m^2),

13.2.1.5 Total mass loss (in kg),

13.2.1.6 Total percentage of mass loss (in %),

13.2.1.7 Peak concentration of carbon monoxide (in ppm),

13.2.1.8 Peak temperatures (in $^{\circ}\text{C}$),

13.2.1.9 Equations used to calculate rate of heat release,

13.2.1.10 Peak optical density of smoke (optional),

13.2.1.11 Average optical density of smoke, over the 10 min period including the peak (optional),

13.2.1.12 Total percentage of combustible mass loss (in %) (optional),

13.2.1.13 Average yield of carbon monoxide (in g CO/g fuel) (optional),

13.2.1.14 Average yield of carbon dioxide (in g CO_2/g fuel) (optional),

13.2.1.15 Carbon monoxide/carbon dioxide molar yield ratio (optional),

13.2.1.16 Average yield of any other measured combustion gas (in g combustion gas/g fuel) (optional), and

13.2.1.17 Report smoke obscuration, carbon monoxide, and temperature measurements in the room in the same fashion, if they have been made (optional).

13.2.2 *Graphical Results (Optional):*

13.2.2.1 Plot of rate of heat release versus time,

13.2.2.2 Plot of rate of smoke release versus time,

13.2.2.3 Plot of optical density versus time,

13.2.2.4 Plot of mass loss versus time,

13.2.2.5 Plot of concentration of carbon monoxide versus time,

13.2.2.6 Plot of concentration of carbon dioxide versus time,

13.2.2.7 Plots of concentration of any other measured combustion gas versus time,

13.2.2.8 Plot of mass flow rate in the exhaust duct versus time,

13.2.2.9 Plot of duct temperature versus time, and

13.2.2.10 Report smoke obscuration, carbon monoxide, and temperature measurements in the room in the same fashion, if they have been made.

13.2.3 *Descriptive Results:*

13.2.3.1 Photographs or videotape of the fire development, and

13.2.3.2 All available information requested in 11.2.7.

14. Precision and Bias

14.1 *Precision*—The precision of this test method has not been determined. Results of a planned interlaboratory test series will be included when available.

14.2 *Bias:*

14.2.1 No information is presented on the bias of the procedure in this test method because correct values of fire-test-response characteristics of upholstered furniture can only be defined in terms of a test method. Within this limitation, this test method has no known bias and can be accepted as a reference method.

14.2.2 For solid specimens of unknown chemical composition, as used in building materials, furnishings, and common occupant fuel load, it has been documented that the use of the oxygen consumption standard value of 13.1 MJ/kg oxygen for the net amount of heat released per unit of oxygen consumed for complete consumption, results in an expected error band of $\pm 5\%$ compared to the true value. For homogeneous materials with only a single pyrolysis mechanism, this uncertainty is reduced by determining the net heat of combustion from oxygen bomb measurements and the stoichiometric oxygen/fuel mass ratio from ultimate elemental analysis. For testing relevant to this standard, this is not practical, since specimens are finished products, some of which are nonhomogeneous and capable of exhibiting degradation reactions. Therefore, for unknown specimens, a $\pm 5\%$ accuracy limit is seen. For reference materials, however, careful determination of the net heat released per unit of oxygen consumed can make this source of uncertainty substantially less.

15. Keywords

15.1 calorimetry; carbon dioxide; carbon monoxide; fire; fire-test-response; heat release; ignition; mock-up; oxygen consumption; smoke obscuration; toxic combustion gases; upholstered furniture

(Mandatory Information)

A1. DESIGN OF MOCK-UP

A1.1 In lieu of testing finished products, full-scale mock-up testing is performed on mock-ups constructed according to the following specimen construction directives:

A1.1.1 The test specimen shall consist of component cushions that duplicate the thickness, construction, and design features of a product suitable for use.

A1.1.2 A metal test frame (see Fig. A1.1 and Fig. A1.2) shall be used to support seat and back cushions and, if necessary, arm cushions. The test frame shall be of steel construction. The back wall shall be constructed so that it is adjustable to a maximum angle of 135° from the horizontal plane. The test frame shall be adjustable to accommodate test cushions of various thicknesses and sizes, with or without arm cushions.

A1.1.3 Component back, seat, and arm cushions shall be constructed into mock-up designs of the actual article of furniture. Construction shall duplicate all layers found in the actual article of furniture. Cushion construction shall consist of either:

A1.1.3.1 Manufacturer's prefabricated cushions of the appropriate size, or

A1.1.3.2 Custom-made cushions of the appropriate size. Cushions are constructed by covering the face and four edges of the filling material with the interliners, if appropriate, and cover fabric. On the back of each cushion, a 50 mm (2 in.) overlap of the cover fabric is stapled together, and a wire is loosely woven through the fabric edges and drawn to produce a close fit (see Fig. A1.3).

A1.1.4 The constructed seat cushion shall be placed horizontally on the seat area of the test frame and pushed against the back of the frame. The constructed back cushion shall then be placed vertically against the back support of the test frame. The back cushion shall be held in place by wire to prevent it

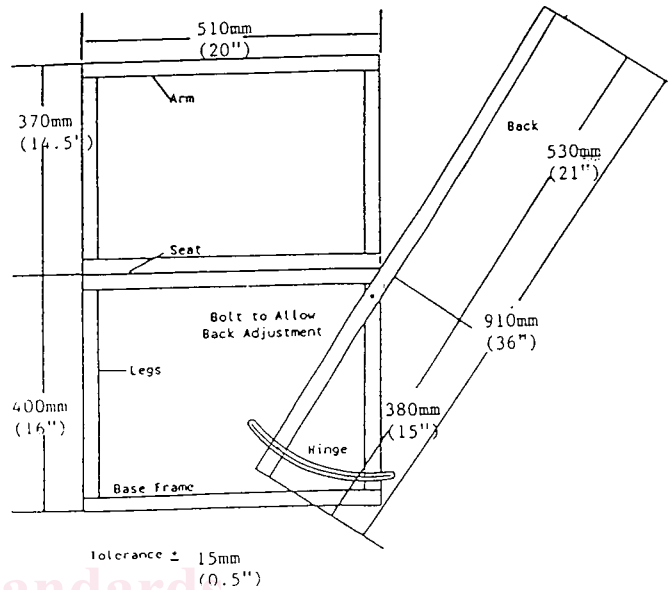

FIG. A1.2 Metal Test Frame (End View)

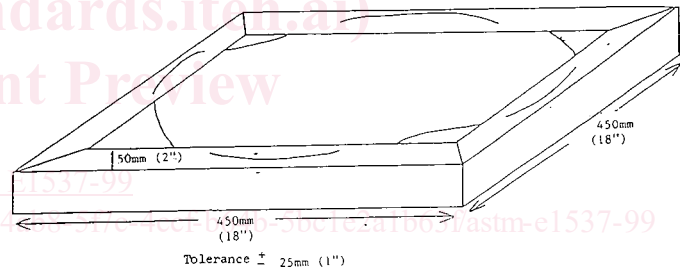

FIG. A1.3 Back View of Constructed Cushion

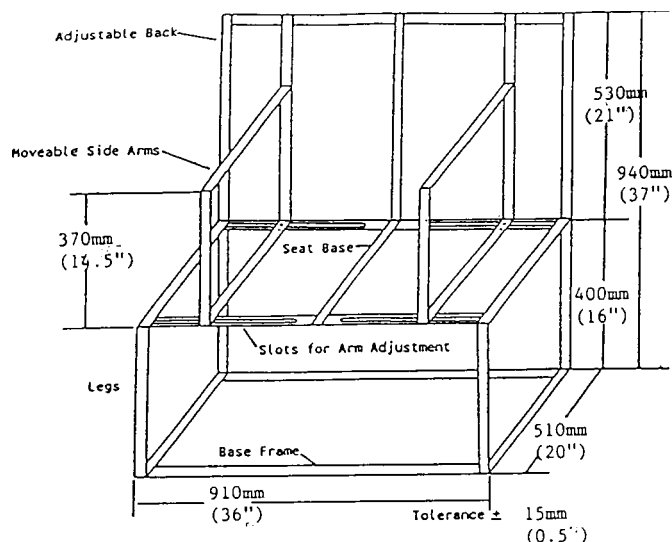

FIG. A1.1 Metal Test Frame

from falling forward. If arm cushions are used, the constructed arm cushions shall be placed between the seat cushion and the arm supports of the test frame. However, the placement of the seat, back, and arm cushions shall be done to most closely duplicate the design features of the completed article of furniture. If any plastic frames or decorative parts are to be used, they shall also be included in the mock-up tested.

A1.1.5 The frame shall have a total length of 0.9 m (36 in.), a width of 0.5 m (20 in.), and an overall height of 0.93 m (37 in.). The back shall be hinged with 0.4 m (16 in.) from the seat to the floor and 0.53 m (21 in.) above the seat. The moveable side arms shall be 0.37 m (14.5 in.) high and 0.50 m (20 in.) wide (see Fig. A1.1). The tolerances of all measures shall be 12 mm (0.5 in.). The bottom of the frame shall be covered with a wire net having 45 ± 5 mm mesh size.

A1.1.6 The constructed cushions shall be 450 by 450 by 50 mm nominal thickness (18 by 18 by 2 in.). The thickness of the cushions may vary due to type of filling, presence of interliner, and type of fabric. The given cushion sizes are nominal for 50 mm foam thickness and shall be slightly adjusted to fit a given test set-up.