



SLOVENSKI STANDARD

SIST EN 2886:2001

01-januar-2001

Aerospace series - Screws, pan head, offset cruciform recess, close tolerance normal shank, short thread, in alloy steel, cadmium plated - Classification: 900 MPa (at ambient temperature)/235°C

Aerospace series - Screws, pan head, offset cruciform recess, close tolerance normal shank, short thread, in alloy steel, cadmium plated - Classification: 900 MPa (at ambient temperature)/235 °C

Luft- und Raumfahrt - Flachkopf-Paßschrauben mit Flügelkreuzschlitz, kurzes Gewinde, aus legiertem Stahl, verkadmet - (Klasse 900 MPa (bei Raumtemperatur)/235°C)

Série aérospatiale - Vis à tête cylindrique, à empreinte cruciforme déportée, tige normale à tolérance serrée, filetage court, en acier allié cadmiées - Classification: 900 MPa (a température ambiante)/235°C

Ta slovenski standard je istoveten z: EN 2886:1996

ICS:

49.030.20 Sorniki, vijaki, stebelni vijaki Bolts, screws, studs

SIST EN 2886:2001

en

iTeh STANDARD PREVIEW
(standards.iteh.ai)

SIST EN 2886:2001

<https://standards.iteh.ai/catalog/standards/sist/5556f9e3-bb2e-458f-801a-c49aca61ff2a/sist-en-2886-2001>

EUROPEAN STANDARD

EN 2886

NORME EUROPÉENNE

EUROPÄISCHE NORM

July 1996

ICS 49.040.20

Descriptors: aircraft industry, screw, cheese head screw, cross recessed screw, alloy steel, specification, dimension, dimensional tolerance, surface treatment, designation, marking

English version

**Aerospace series - Screws, pan head, offset
cruciform recess, close tolerance normal shank,
short thread, in alloy steel, cadmium plated -
Classification : 900 MPa (at ambient
temperature)/235 °C**

Série aérospatiale - Vis à tête cylindrique, à
empreinte cruciforme déportée, tige normale à
tolérance serrée, filetage court, en acier
allié, cadminées - Classification : 900 MPa (à
température ambiante)/235 °C

Luft- und Raumfahrt - Flachkopf-Paßschrauben
mit Flügelkreuzschlitz, kurzes Gewinde, aus
legiertem Stahl, verkadmet - Klasse : 900 MPa
(bei Raumtemperatur)/235 °C

SIST EN 2886:2001

<https://standards.iteh.ai/catalog/standards/sist/5556f9e3-bb2e-458f-801a-c49aca61ff2a/sist-en-2886-2001>

This European Standard was approved by CEN on 1996-06-29. CEN members are bound to comply with the CEN/CENELEC Internal Regulations which stipulate the conditions for giving this European Standard the status of a national standard without any alteration.

Up-to-date lists and bibliographical references concerning such national standards may be obtained on application to the Central Secretariat or to any CEN member.

The European Standards exist in three official versions (English, French, German). A version in any other language made by translation under the responsibility of a CEN member into its own language and notified to the Central Secretariat has the same status as the official versions.

CEN members are the national standards bodies of Austria, Belgium, Denmark, Finland, France, Germany, Greece, Iceland, Ireland, Italy, Luxembourg, Netherlands, Norway, Portugal, Spain, Sweden, Switzerland and United Kingdom.

CEN

European Committee for Standardization
Comité Européen de Normalisation
Europäisches Komitee für Normung

Central Secretariat: rue de Stassart, 36 B-1050 Brussels

Foreword

This European Standard has been prepared by the European Association of Aerospace Manufacturers (AECMA).

After inquiries and votes carried out in accordance with the rules of this Association, this Standard has received the approval of the National Associations and the Official Services of the member countries of AECMA, prior to its presentation to CEN.

This European Standard shall be given the status of a national standard, either by publication of an identical text or by endorsement, at the latest by January 1997, and conflicting national standards shall be withdrawn at the latest by January 1997.

According to the CEN/CENELEC Internal Regulations, the national standards organizations of the following countries are bound to implement this European Standard: Austria, Belgium, Denmark, Finland, France, Germany, Greece, Iceland, Ireland, Italy, Luxembourg, Netherlands, Norway, Portugal, Spain, Sweden, Switzerland and the United Kingdom.



1 Scope

This standard specifies the characteristics of screws, pan head, offset cruciform recess, close tolerance normal shank, short thread, in alloy steel, cadmium plated.

Classification : 900 MPa ¹⁾ / 235 °C ²⁾

2 Normative references

This European Standard incorporates by dated or undated reference provisions from other publications. These normative references are cited at the appropriate places in the text and the publications are listed hereafter. For dated references, subsequent amendments to or revisions of any of these publications apply to this European Standard only when incorporated in it by amendment or revision. For undated references the latest edition of the publication referred to applies.

ISO 3353	Aerospace - Rolled threads for bolts - Lead and runout requirements
ISO 5855-2	Aerospace - MJ threads - Part 2 : Limit dimensions for bolts and nuts
ISO 7689	Aerospace - Alloy steel bolts with strength classification 1 100 MPa and MJ threads - Procurement specification
ISO 7913	Aerospace - Bolts and screws, metric - Tolerances of form and position
ISO 7994	Aerospace - Internal drive, offset cruciform recess (Torq-Set [®]) for rotary fastening devices - Metric series
EN 2000	Aerospace series - Quality assurance - EN aerospace products - Approval of the quality system of manufacturers
EN 2133	Aerospace series - Cadmium plating of steels, with maximum specified tensile strength equal to or less than 1 450 MPa, copper, copper alloys and nickel alloys ³⁾
EN 2424	Aerospace series - Marking of aerospace products
EN 4016	Aerospace series - Oversized bolts ⁴⁾
TR 3775	Aerospace series - Bolts and pins - National materials ⁵⁾

1) Minimum tensile strength of the material at ambient temperature

2) Maximum temperature that the screw can withstand without continuous change in its original characteristics, after return to ambient temperature. The maximum temperature is determined by the surface treatment.

3) Published as AECMA Standard at the date of publication of this standard

4) Published as AECMA Prestandard at the date of publication of this standard

5) Published as AECMA Technical Report at the date of publication of this standard

3 Required characteristics

3.1 Configuration - Dimensions - Masses

See figure 1 and table 1.

Dimensions and tolerances are expressed in millimetres and apply after surface treatment.

3.2 Tolerances of form and position

ISO 7913

3.3 Materials

TR 3775 (alloy steel, strength class 900 MPa)

3.4 Surface treatment

EN 2133, 8 μm to 14 μm , on all surfaces which can be contacted by a 20 mm diameter ball. On all other surfaces, a continuous deposit shall be present, but no value is specified.

Black colour option : code B

iTeh STANDARD PREVIEW
(standards.iteh.ai)

[SIST EN 2886:2001](https://standards.iteh.ai/catalog/standards/sist/5556f9e3-bb2e-458f-801a-c49aca61ff2a/sist-en-2886-2001)

<https://standards.iteh.ai/catalog/standards/sist/5556f9e3-bb2e-458f-801a-c49aca61ff2a/sist-en-2886-2001>

$3,2 \sqrt{\quad} \left[\begin{matrix} 0,8 \\ \sqrt{\quad} \end{matrix} \right]$

Values in micrometres apply prior to surface treatment.

Break sharp edges 0,1 to 0,4.

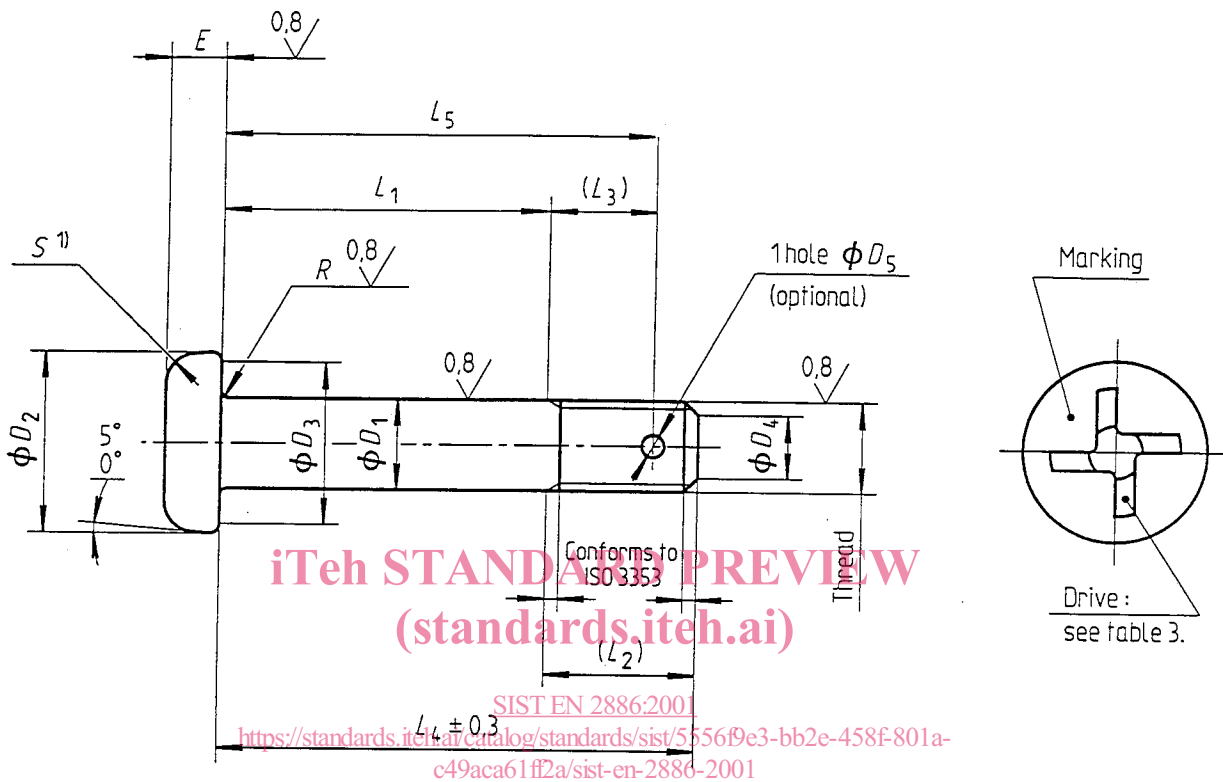

1) Shape optional

Figure 1

Table 1

Diameter code	Thread ¹⁾	D_1		D_2 0 - 0,3	D_3 min.	D_4		D_5 H13	E	
		nom.	Tol.			nom.	Tol.		nom.	Tol.
030	MJ3x0,5 - 4h6h	3	- 0,006 - 0,031	6	4,7	2,3	0 - 0,5	-	1,8	0 - 0,2
040	MJ4x0,7 - 4h6h	4	- 0,010 - 0,035	8	6,7	3		1,1	2,4	
050	MJ5x0,8 - 4h6h	5		10	8,7	3,4	$\pm 0,5$	1,5	3	
060	MJ6x1 - 4h6h	6	12	10,7	4,2	3,6				
070	MJ7x1 - 4h6h	7	- 0,013 - 0,038	14	12,7	5,2		1,9	4,2	
080	MJ8x1 - 4h6h	8		16	14,7	6,2			4,8	
100	MJ10x1,25 - 4h6h	10	20	18,7	7,9	2,4		6		
120	MJ12x1,25 - 4h6h	12	- 0,016 - 0,041	24	22,7		9,8	7,2		

Diameter code	$L_1 \pm 0,2$ ^{2) 3)}		L_2	L_3	R		S		Mass ⁴⁾	
	Code	nom.			nom.	Tol.	max.	min.	5)	6)
030	002 to 030	2 to 30	6	6	0,4	0	1,2	0,3	0,67	0,06
040	002 to 040	2 to 40	7,5	5	0,5	0	1,6	0,4	1,63	0,10
050	003 to 050	3 to 50	9	6			2	0,5	3,31	0,15
060	003 to 060	3 to 60	10	11	0,7	- 0,2	2,4	0,6	5,47	0,22
070	004 to 070	4 to 70	11				2,8	0,7	9,36	0,30
080	004 to 080	4 to 80	11,5	7,5	0,8	0	3,2	0,8	12,76	0,40
100	005 to 100	5 to 100	14,5	9			4	1	25,12	0,61
120	006 to 120	6 to 120	16	10	0,9	0	4,8	1,2	44,39	0,89

1) In accordance with ISO 5855-2, except the thread major diameter "d max." which shall be equal to D_1 min. - 0,025.

2) Increments :

1 for $L_1 \leq 30$

2 for $30 < L_1 \leq 100$

4 for $L_1 > 100$

3) If greater lengths are required, they shall be chosen using the above increments. The length code corresponds to the length L_1 , completed by one or two zeros to the left, where necessary, to obtain a three digit code.

4) Approximate values (kg/1 000 pieces), calculated on the basis of 7,85 kg/dm³, given for information purposes only. They apply to screws without hole.

5) Value for head and first L_4

6) Increase for each additional millimetre of L_4 .

4 Designation

EXAMPLE :

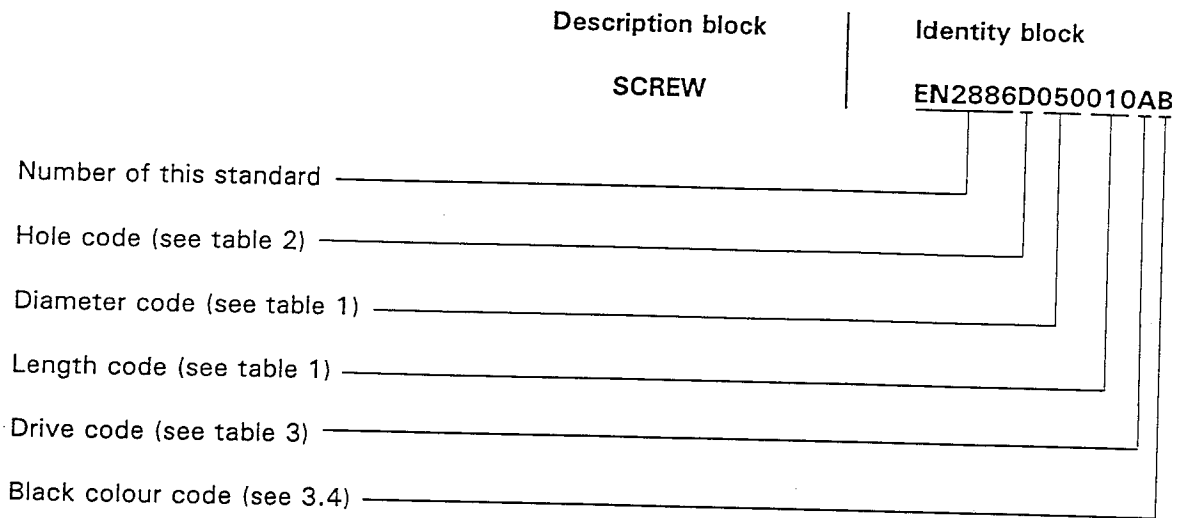

NOTE : If necessary, the code I9005 shall be placed between the description block and the identity block.

iTeh STANDARD PREVIEW
(standards.iteh.ai)

Table 2

Hole	Code
with	— (hyphen)
without	— (hyphen)

Table 3

Drive	Code
ISO 7994	R
ISO 7994 unribbed	A

5 Marking

See table 4 and figure 1, indented.

Table 4

Diameter code	EN 2424 Style
030 and 040	N
050 to 120	C + MJ