



Standard Guide for Lock-Strip Gasket Glazing¹

This standard is issued under the fixed designation C 964; the number immediately following the designation indicates the year of original adoption or, in the case of revision, the year of last revision. A number in parentheses indicates the year of last reapproval. A superscript epsilon (ϵ) indicates an editorial change since the last revision or reapproval.

1. Scope

1.1 This guide covers the use of lock-strip gaskets in compliance with Specification C 542 in walls of buildings not over 15° from a vertical plane. The prime performance considerations are weathertightness against air and water infiltration, and structural integrity under wind loads. Included are terminology, design considerations, and fabrication tolerances when using lock-strip gaskets in glazing applications.

1.2 The values stated in inch-pound units are to be regarded as the standard. The SI units in parentheses are for information only.

1.3 *This standard does not purport to address all of the safety concerns, if any, associated with its use. It is the responsibility of the user of this standard to establish appropriate safety and health practices and determine the applicability of regulatory limitations prior to use.*

2. Referenced Documents

2.1 ASTM Standards:

- C 542 Specification for Lock-Strip Gaskets²
- C 716 Specification for Installing Lock-Strip Gaskets and Infill Glazing Materials²
- C 717 Terminology of Building Seals and Sealants²
- C 864 Specification for Dense Elastomeric Compression Seal Gaskets, Setting Blocks, and Spacers²
- C 963 Specification for Packaging, Identification, Shipment, and Storage of Lock-Strip Gaskets²
- C 1036 Specification for Flat Glass³
- D 1566 Terminology Relating to Rubber⁴
- E 283 Test Method for Determining the Rate of Air Leakage Through Exterior Windows, Curtain Walls, and Doors Under Specified Pressure Differences Across the Specimen⁵
- E 330 Test Method for Structural Performance of Exterior Windows, Curtain Walls, and Doors by Uniform Static Air Pressure Difference⁵

¹ This guide is under the jurisdiction of ASTM Committee C-24 on Building Seals and Sealants and is the direct responsibility of Subcommittee C24.73 on Compression Seal and Lock-Strip Gaskets.

Current edition approved Sept. 8, 1988. Published March 1989. Originally published as C 964 – 81. Last previous edition C 964 – 87.

² *Annual Book of ASTM Standards*, Vol 04.07.

³ *Annual Book of ASTM Standards*, Vol 15.02.

⁴ *Annual Book of ASTM Standards*, Vol 09.01.

⁵ *Annual Book of ASTM Standards*, Vol 04.11.

E 331 Test Method for Water Penetration of Exterior Windows, Curtain Walls, and Doors by Uniform Static Air Pressure Difference⁵

3. Terminology

3.1 *Definitions*—Refer to Terminology C 717 for definitions of the following terms used in this guide: bite; compound; edge spacer; elastomer; elastomeric; gasket; glazing; hardness; joint; lock-strip gasket; open cell; seal; sealant; setting block; and spacer. Additional elastomeric terms can be found in Terminology D 1566.

3.2 *Definitions of Terms Specific to This Standard:*

3.2.1 *clamping pressure*—the pressure exerted by the lip of a lock-strip gasket on material installed in the channel when the lock-strip is in place.

3.2.2 *durometer*—(1) an instrument for measuring the hardness of rubber-like materials. (2) a term used to identify the relative hardness of rubber-like materials, for example, “low durometer” (relatively soft) or “high durometer” (relatively hard).

3.2.3 *edge clearance*—the distance between the bottom of a channel of a lock-strip gasket and the edge of material installed in the channel (see Figs. 1 and 2).

3.2.4 *elongation*—increase in length, expressed as a percent of the original length.

3.2.5 *filler strip*—see *lock-strip*, the preferred term.

3.2.6 *flange*—that part of a lock-strip gasket that extends to form one side of a channel (see Figs. 1 and 2).

3.2.7 *H-gasket*—See *lock-strip gasket*, and Fig. 1.

3.2.8 *hinge*—the minimum thickness of gasket material between the channel recess and the lock-strip cavity; the plane at which bending occurs when the flange is bent open to receive or release installed material.

3.2.9 *horizontal ladder gasket*—a ladder gasket installed in a vertical plane in such a way that the intermediate cross members (muntins) are vertical members (see Fig. 3).

3.2.10 *ladder gasket*—a lock-strip gasket in the form of a subdivided frame having one or more integrally formed intermediate cross members (see Fig. 3).

3.2.11 *lip*—the inner face of the tip of a flange on a lock-strip gasket (see Figs. 1 and 2).

3.2.12 *lip pressure*—the pressure exerted by the lip of a lock-strip gasket on material installed in the channel when the lock-strip is in place.

3.2.13 *lock-strip or locking strip*—the strip that is designed

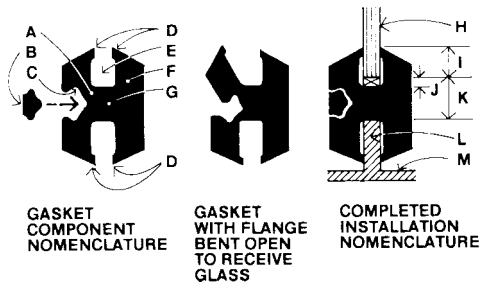

- | | |
|----------------------|----------------------------|
| A Hinge | H Glass or panel |
| B Lock-strip | I Bite |
| C Lock-strip cavity | J Edge clearance |
| D Lip (sealing edge) | K Frame-to-glass dimension |
| E Channel recess | L Frame lug |
| F Flange | M Frame |
| G Web | |

FIG. 1 Basic H-Type Gasket, its Functional Principles and Nomenclature

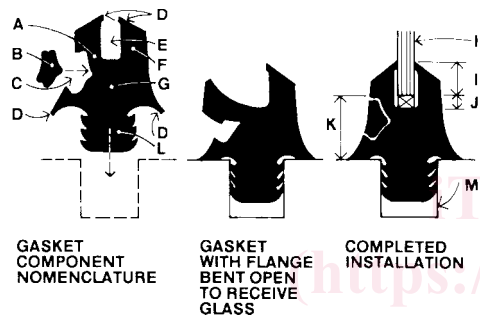

- | | |
|----------------------|----------------------------|
| A Hinge | H Glass or panel |
| B Lock-strip | I Bite |
| C Lock-strip cavity | J Edge clearance |
| D Lip (sealing edge) | K Frame-to-glass dimension |
| E Channel recess | L Spline |
| F Flange | M Reglet |
| G Web | |

FIG. 2 Reglet-type Gasket, its Functional Principles and Nomenclature

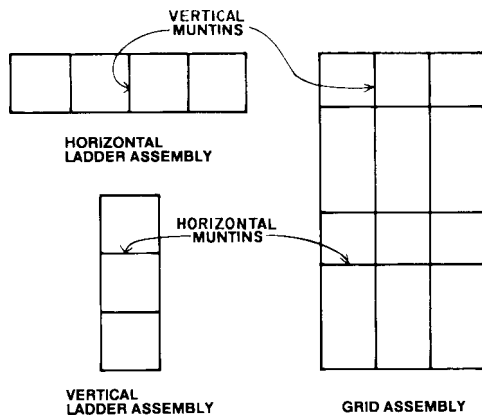

FIG. 3 Gasket Systems

to be inserted in the lock-strip cavity to force the lips against material placed in the channel (see Figs. 1 and 2).

3.2.14 *lock-strip cavity*—the groove in the face of a lock-strip gasket designed to receive and retain the lock-strip (see Figs. 1 and 2).

3.2.15 *muntin*—a secondary intermediate member in a multiple-opening gasket system subdividing a glazed area.

3.2.16 *reglet*—a groove or recess formed in material such as concrete or masonry to receive the spline, or tongue, of a reglet-type lock-strip gasket (see Fig. 2).

3.2.17 *reglet gasket*—See *lock-strip gasket*, and Fig. 2.

3.2.18 *spline or tongue*—that part of a reglet-type lock-strip gasket which is designed to be installed in a reglet in supporting material (see Fig. 2).

3.2.19 *structural gasket*—See *lock-strip gasket*, the preferred term.

3.2.20 *supported gasket member*—a gasket member held in place by a supporting frame member.

3.2.21 *unsupported gasket member*—a gasket member joining infill materials without being held in place by a supporting frame member.

3.2.22 *vertical ladder gasket*—a ladder gasket installed in a vertical plane in such a way that the intermediate cross members (muntins) are horizontal members (see Fig. 3).

3.2.23 *web*—that part of an H-type lock-strip gasket that extends between the flanges, forming two channels and that part of a reglet-type lock-strip gasket which extends between the flanges and spline (see Figs. 1 and 2).

3.2.24 *zipper gasket*—See *lock-strip gasket*, the preferred term.

4. Significance and Use

4.1 This guide provides information and guidelines for the design of lock-strip gasket glazing systems. For related standards, see Specifications C 542, C 716, and C 963.

DESIGN CONSIDERATIONS

5. General

5.1 Structural integrity and watertightness of a gasket glazing system is dependent on interaction of the several components involved. These systems should be carefully designed and built.

6. Components

6.1 The major components of lock-strip gasket glazing and paneling systems are:

6.1.1 The supporting frame of metal, concrete, or other structural building materials,

6.1.2 Lock-strip gasket, serving as an elastomeric mechanical seal and as a retainer for panel or glass, and

6.1.3 Glass or panel infill.

6.1.4 The design of these components and their accessories are interrelated and the total system must be compatible.

7. Supporting Frames

7.1 Supporting frames are made of many materials, of which the more common are aluminum, steel, and concrete.

7.1.1 *Metal*—Die marks, ridges, offsets, and scratches in metal frames in contact with the gasket lips that could cause leakage should be avoided. Metal in contact with any part of the gasket should have sharp edges and burrs removed to avoid the possibility of damage to the gaskets that could result in structural failure through tear propagation. Weathering steel

frames used in gasket installations should be coated to prevent corrosion on the surfaces covered by the gasket to a line not less than 1/8 in. (3.2 mm) beyond the lip edge when installed.

7.1.2 *Concrete*—Gasket lips in contact with protrusions, crazing, form marks, and offsets on concrete surfaces could cause leakage and glass breakage and such irregularities should be avoided. Concrete frames for lock-strip gaskets should be jointless and are more suitable when precast, as the tolerances and smooth surfaces required are too exacting for cast-in-place concrete. Special forms and meticulous casting procedures are required for optimum performance.

7.1.2.1 *Corner Angles*—Corner angles in the plane of the glass should be held to $\pm 2^\circ$ tolerance to properly receive the gasket lips. See Fig. 4.

7.1.2.2 *Reglets*—It is essential that the recess in the concrete be accurately cast so as to properly receive the spline of the gasket. This can be accomplished with a plastic reglet that has a removable weakness membrane as shown in Fig. 4. The removable membrane maintains the proper recess shape and keeps concrete out of the reglet while being cast. The removable membrane can be T-shaped, when desirable, with the stem projecting from the reglet to provide a more convenient means of attachment to the formwork of the concrete panel. After casting, the weakness membrane is easily removed. Plastic reglets are available with flanges extending beyond the gasket lips, providing smooth contact surfaces. An advantage of the plastic flange is the provision of a smooth rigid surface for contact with the gasket lip. The plastic flanges are butted together at the corners requiring a joint which should be properly aligned and sealed. The exposed plastic flange should be solidly cast into the concrete without any voids or honeycombing at the leading edge of the flange because water could enter the interface between the flange and the concrete into which it is cast. An advantage of the flangeless reglet is that the exposed joint between the flange and the concrete as well as the corner butt joints are eliminated and the gasket lips make direct contact with the concrete frame. With this concept it is essential to have a continuous smooth surface free of voids or

honeycombing for the gasket lips to seal against because water could bypass the gasket lip and enter under it. Also important is to have a sharp arris at the corners of the concrete frame so that the corners of the gasket lip can properly contact and seal against the concrete. When plastic reglets are used, joints in them could cause leaks unless sealed. When the gasket lips are in direct contact with the concrete, meticulous casting procedures and close surveillance are required to assure a proper finish along the contacting surface.

7.1.2.3 *Frame Lug*—It is difficult to achieve watertightness with a gasket gripping the lug of a concrete frame as shown in Fig. 5. Casting the lug to the $\pm 1/32$ -in. (0.8-mm) tolerance required is unrealistic when dealing with concrete. Also, casting it without a tapered draft for ease of form removal results in complicated form work. A tapered draft provides poor control over gasket lip pressure and results in a reduction of pressure when excessive edge clearance permits the gasket lips to slip to the narrower part of the lug. Unless the gasket gripping the lug of a concrete frame has enough mass, insufficient lip pressure against the concrete frame and leakage could result because of the relatively large lug width.

7.1.3 *Joints*—Ideally, the best type of frame over which to seat the gasket is one without joints. However, the realities of construction should be recognized and dealt with. Watertightness between the lock-strip gasket and frame depends on unbroken pressurized contact. Joints in metal, unless welded and ground flush and smooth, make this concept difficult to achieve. Members on either side of a butt joint should be installed as true to plane as possible. If the design relies upon sealed metal-to-metal joints, the small void between the gasket lip and metal should also be sealed with a supplementary sealant. A recommended safeguard is to have a built-in drainage system within the frame. In this way, any water penetrating the frame joints or gasket to frame joints will be directed back to the outdoors. An aid towards minimizing the possibility of water penetration between the gasket and frame at static (fixed, nonmoving) metal joints in single openings may be seen in Fig. 6. The direction of the joint is horizontal between the horizontal and vertical members at the top of the frame, and vertical between the horizontal and vertical members at the bottom of the frame.

7.1.4 *Frame-to-Gasket Lips Clearance*—Because lip pressure is critical in resisting the passage of water, the design of the supporting frame must allow at least 1/8-in. (3.2-mm) clearance between the installed gasket lip and any projecting

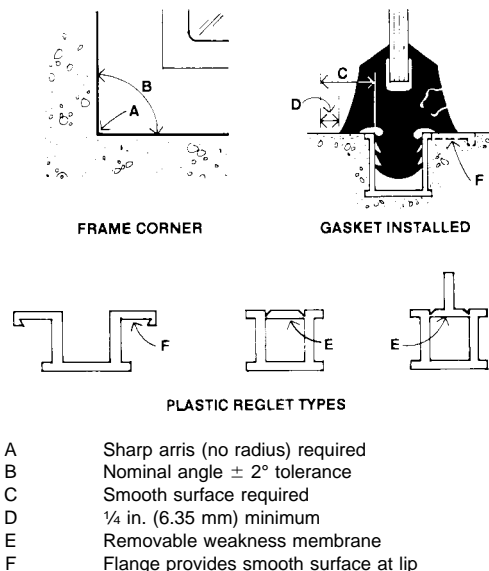
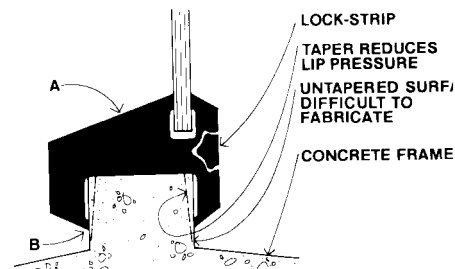

FIG. 4 Reglet-type Gasket in Concrete



NOTE 1—Insufficient mass at A and relative long distance from B to lock-strip minimizes potential for adequate lip pressure at B.

FIG. 5 Gasket Mounting on Concrete Lug

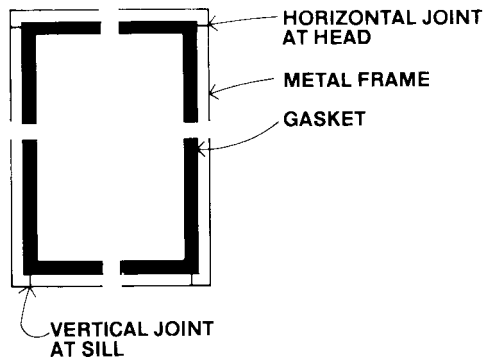

FIG. 6 Single-opening Metal Frame Joints for Increased Watertightness

flanges or fillets. This allows the lips to exert unrestricted pressure against the frame as shown in Fig. 7. Where the frame lug and projecting flange form a fillet, the recommended clearance should not include the convex portion.

8. Gaskets and Accessories

8.1 To accommodate the wide variety of glass and panel thicknesses available as well as allow for mounting to various types of framing members, a wide variety of gasket cross sections are produced by the extrusion manufacturing process. The technique of extruding varies among the manufacturers, and has a limiting factor on the complexity of cross-section designs produced.

8.1.1 Gasket Types—Lock-strip gaskets are typically identified by their general cross-section configuration. The most common are H-type and reglet type. Other special and proprietary interlocking types have been developed as a result of modifications to the basic types, usually because of provisions for mounting or mating to special framing members. Gasket sections are generally of two types: the perimeter section and the muntin section.

8.1.1.1 H-Type—The basic H-type gasket, its installation, and nomenclature are illustrated in Fig. 1. After the gasket is installed over the frame and the glass or panel infill installed in the gasket, the lock-strip, which is of higher durometer, is forced into a groove in the gasket. A resultant compressive force is transferred to the lips which apply pressure to the frame and glass. Sufficient lip pressure against smooth surfaces creates an effective weathertight seal. A wide selection of H-type gaskets are available that accommodate glass, panels, and frame lug thicknesses ranging from 1/16 to 1 1/4 in. (1.6 to 31.75 mm). Gaskets accommodating thicknesses greater than 1 1/4 in. are also available. Thick panels should not be mounted on relatively thin lugs as the weight of the glass or panel cannot

be supported properly. The best performance can be expected where the lug thickness equals or exceeds the thickness of the glass or panel. There are exceptions to this recommendation which are dependent upon other factors, such as lightweight panels, extremely small openings, or situations where total performance is not required. Acceptable deviations require engineering analysis, consultation with the gasket manufacturer, and testing.

8.1.1.2 Reglet Type—The reglet-type gasket is a patented type whose functional principles and nomenclature are illustrated in Fig. 2. Reglet-type gaskets are designed with a spline that fits into a reglet. The seal against the frame is accomplished by forcing the spline of the gasket into the reglet so that the fins on the side of the spline retain the gasket in the reglet and thus hold the sealing lips of the gasket tightly against the frame surface. The seal against the glass or panel is accomplished by the insertion of the lock-strip as with the H-type gasket. Most reglet-type gaskets are designed to fit into a reglet that is 3/4 in. (19.05 mm) deep and 5.8 in. (15.9 mm) wide. If the reglet is of lesser depth, the gasket will “bottom-out” and not provide a proper installation. If the reglet is too wide, the gasket will not be held in place properly and thereby provide difficult glass or panel installation. If the reglet is too narrow, the gasket will be difficult to install. Reglet-type gaskets are available that accommodate glass or panel thicknesses from 1/16 through 1 1/4 in. (1.6 through 31.75 mm). There is an important basic difference between the H-type and reglet-type gaskets that should not be overlooked in field application. The lock-strip of both gaskets causes lip pressure against the frame and glass, but with the reglet-type gasket, lip pressure is also affected by the depth of the gasket spline in the reglet. This is controlled by the installer at the site as well as by the geometry of the gasket and reglet. Available are reglet-type gaskets that have projecting offsets at the upper or lower part of the spline. These are designed to control the depth at which the spline is inserted into the reglet.

8.1.1.3 Special Interlocking and Proprietary Types—In addition to the basic H-type and reglet-type gaskets, there are various special interlocking and proprietary type gaskets. Several of these are illustrated in Fig. 8. The basic principle of the interlocking type is to achieve greater roll-off resistance of the gasket from the frame by mechanically interlocking the gasket to the frame.

8.1.2 Gasket Joints—Best sealing performance is achieved with a continuous gasket having factory-formed injection-molded joints. In the use of discontinuous ladder-type gaskets or stick systems (assembled in the field, using cut lengths), achieving a weathertight seal requires a field application of sealant or adhesive recommended by the gasket manufacturer. Geometric continuity should be achieved at the juncture of extrusion and molded joint. Sharp offsets, the limits of which have not as yet been established, can break the continuity of the lip seal and prevent or reduce water tightness.

8.1.2.1 Corners—Continuous and adequate lip pressure provided by the gasket against frame and glass is a key factor in the design of the gasket for watertightness. A pressure of 4 lbf/linear in. (7 N/linear cm) has been determined to be the minimum that will satisfy this requirement. However, of

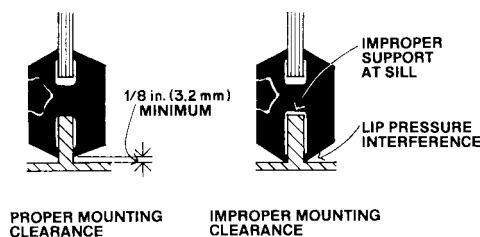

FIG. 7 Gasket Mounting Clearance

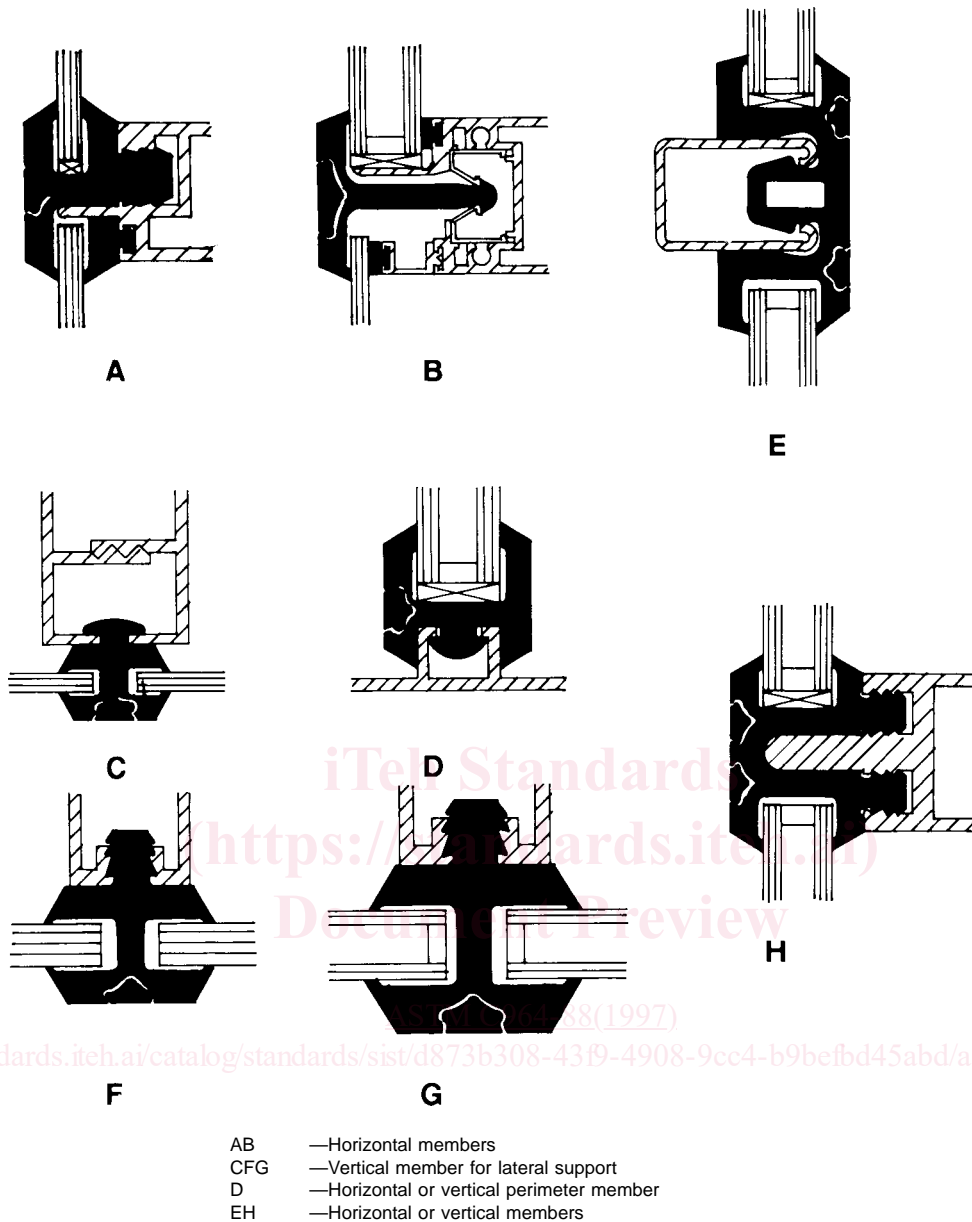

FIG. 8 Special Interlocking and Proprietary Type Gaskets

utmost importance is the requirement that this pressure be continuous and uniform at every point along the lip of the gasket. The present lip pressure test in Specification C 542, is a test for average lip pressure over the entire test specimen length. When applied to the extruded portion of the gasket, it can reasonably be assumed that the pressure would be continuous and uniform at every point, provided the gasket lips are not damaged. This is not necessarily true of the molded corners. Gaskets of various corner designs can pass the lip pressure test, but not all have the capability of sealing out the passage of water. This may be the case with a corner having square lips on the frame side where, because of the longer diagonal distance to the lock-strip, little or no lip pressure may be obtained at the apex. It should not be assumed that passage of the lip pressure test in Specification C 542 provides assurance that the gasket is adequate for resistance to the passage of water. Gasket corner

designs having square lip seals are not as common as previously. Gaskets having approximately 1/4 in. (6.35 mm) radius at the external corner lips are now available. With such a design, a more uniform edge distance is maintained from the lip edge to the lock-strip as shown in Fig. 9. In this way, lip pressure is

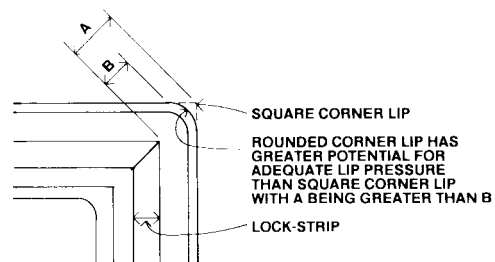

FIG. 9 Gasket Corner Design Features

not generally reduced around the corner as with a square lip because of the appreciably longer moment arm. Generally the round lip is concealed by an external noncontacting square lip for appearance but the seal is provided by the contacting round lip. The angle of the gasket molded corner should conform within 5° to the corner angle of the frame. Molded corner angles of less than 45° should be avoided as the insertion of an extremely acute corner angle is impossible without damage to the molded corner or panel unit.

8.1.2.2 Tees and Crosses—Tees permit the juncture of the perimeter member of a gasket to a muntin member. Crosses allow for division of a glazed area horizontally and vertically. Crosses and tees can be injection molded as well as corners. The corner angle conformation tolerance of $\pm 5^\circ$ is also a requirement for tees and crosses.

8.1.2.3 Butted Joints—Where feasible, long sections of gaskets should be joined end to end by factory-injection molding. Where field-butt joints are required, an application of sealant or adhesive recommended by the gasket manufacturer should be used in the joint under compression to achieve weathertightness.

8.1.3 Lock-Strips—The purpose of lock-strips is to apply pressure to the gasket sealing lips, causing the lips to grip and seal against both the frame and the glass or panel. Lock-strips may be separate from, or an integral part of, the gasket proper. The separate lock-strip should be 10 points harder in Shore A durometer than the gasket itself. The additional hardness of the lock-strip resists deformation under compression and maintains the designed gasket lip pressure for longer periods than would a lock-strip of equal size of a lower durometer.

8.1.4 Gasket Systems—A gasket system is produced when perimeter gaskets and muntin gaskets are assembled and designed to mate with corresponding frame members as a total unit. Gasket systems are referred to as (a) supported, in which all the muntin members are metal supported gasket members; or (b) unsupported, in which vertical muntin gaskets are unsupported by metal members. Supported systems should be used where optimum performance is required.

8.1.4.1 H-Type System—An H-type system uses an H-type gasket for the perimeter as well as for the muntins. This system permits using a glass panel and a spandrel panel, or a glass panel and a panel containing an operating window insert, in the same system. The gasket manufacturer should be consulted prior to designing such a system, to ensure that perimeter and muntin gaskets are compatible and can be joined together to produce a favorable system.

8.1.4.2 Reglet-Type System—A reglet-type system typically includes a reglet-type gasket for the perimeter and a supported or unsupported H-type gasket for the muntins. The reglet type systems require a greater control over the opening dimensions, particularly if the opening is of concrete. The tolerances published by the gasket manufacturer for reglet-type systems should be followed.

8.1.4.3 Stick System—A stick system incorporates gaskets that are straight lengths of extrusions cut to size and joined during installation in the field. Manufacturer's recommendations should be followed regarding the installation techniques to be used as well as the type and location of adhesives or

sealants to be used for the joints.

8.1.4.4 Ladder Assembly System—A ladder assembly system is produced by vulcanizing muntin gasket extrusions to perimeter gasket extrusions with the use of an injection-molded Tee-joint. These may be vertical or horizontal ladder assembly systems as shown in Fig. 3. Production experience shows that a ladder gasket assembly larger than 20 ft (6.1 m) in length becomes too difficult to fabricate or handle. Field installation problems are also encountered. Where large areas are to be glazed using the ladder gasket assembly, the assemblies are produced in conveniently sized sections, and joined in the field. Joining is accomplished by butting under compression ("crowding") the free ends of the gaskets together. A weather-tight seal can be accomplished by the injection of an appropriate adhesive or sealant recommended by the gasket manufacturer in the butted gasket joint after the unit is glazed and lock-strip inserted. In horizontal ladder systems where the vertical gasket member is unsupported the vertical gasket is used only as a weather seal and does not provide any significant structural support to the vertical glass edges. For vertical ladder systems the horizontal gasket members must be supported (see 10.1.10.4).

8.1.4.5 Grid Assembly System—A grid assembly system is one in which horizontal and vertical muntin gaskets intersect within the perimeter gaskets as shown in Fig. 3. Intersecting muntin gaskets are assembled by a molded joint. All grid systems should be of the supported type.

8.1.5 Setting Blocks—The purpose of setting blocks is to provide positive support, but prevent direct contact between the bottom of the glass or panel and the web of the sill gasket member. A certain amount of vertical edge clearance is required in order to install the gasket without tearing the upper corners of the gasket. If the glass or panel were to be installed directly onto the web of the sill gasket member, too much edge clearance would be left at the head member. With setting blocks, the glass or panel can be lowered down to the web of the sill member for easier glass insertion at the head and then raised within the gasket enclosure for insertion of setting blocks to provide the desired edge clearance space at the sill member before the lock-strip is installed. Factors to consider in the use of setting blocks are (a) compatibility of materials, (b) location and quantity, (c) avoidance of support at the gasket corners, (d) maximum pressure permitted on the gasket-bearing surface under the setting blocks, and (e) geometry of the setting blocks with regard to the gasket, to the gasket cross section, and glass or panel width.

8.1.5.1 Material—The setting block material should be an elastomer of Shore A durometer of 85 ± 5 , of rectangular cross section, dimensionally stable, causing no interactive deterioration of it, the gasket, or the glass or panel infill and in compliance with Specification C 864.

8.1.5.2 Location—A continuous strip or two setting blocks at the quarter points are permissible, provided the maximum pressure described in 8.1.5.3 is not exceeded. The continuous strip should be cut short of the width by 4 in. (101.6 mm).

8.1.5.3 Width—The width of setting blocks should be 0.05 in. (1.27 mm) less than the nominal glass or panel thickness. Less width could result in improper support for the glass or