

# INTERNATIONAL STANDARD

## NORME INTERNATIONALE



**Industrial communication networks – Profiles –  
Part 3: Functional safety fieldbuses – General rules and profile definitions**

**Réseaux de communication industriels – Profils –  
Partie 3: Bus de terrain de sécurité fonctionnelle – Règles générales et  
définitions de profils**



## THIS PUBLICATION IS COPYRIGHT PROTECTED

Copyright © 2010 IEC, Geneva, Switzerland

All rights reserved. Unless otherwise specified, no part of this publication may be reproduced or utilized in any form or by any means, electronic or mechanical, including photocopying and microfilm, without permission in writing from either IEC or IEC's member National Committee in the country of the requester.

If you have any questions about IEC copyright or have an enquiry about obtaining additional rights to this publication, please contact the address below or your local IEC member National Committee for further information.

Droits de reproduction réservés. Sauf indication contraire, aucune partie de cette publication ne peut être reproduite ni utilisée sous quelque forme que ce soit et par aucun procédé, électronique ou mécanique, y compris la photocopie et les microfilms, sans l'accord écrit de la CEI ou du Comité national de la CEI du pays du demandeur.

Si vous avez des questions sur le copyright de la CEI ou si vous désirez obtenir des droits supplémentaires sur cette publication, utilisez les coordonnées ci-après ou contactez le Comité national de la CEI de votre pays de résidence.

IEC Central Office  
3, rue de Varembe  
CH-1211 Geneva 20  
Switzerland  
Email: [inmail@iec.ch](mailto:inmail@iec.ch)  
Web: [www.iec.ch](http://www.iec.ch)

### About the IEC

The International Electrotechnical Commission (IEC) is the leading global organization that prepares and publishes International Standards for all electrical, electronic and related technologies.

### About IEC publications

The technical content of IEC publications is kept under constant review by the IEC. Please make sure that you have the latest edition, a corrigenda or an amendment might have been published.

- Catalogue of IEC publications: [www.iec.ch/searchpub](http://www.iec.ch/searchpub)

The IEC on-line Catalogue enables you to search by a variety of criteria (reference number, text, technical committee,...). It also gives information on projects, withdrawn and replaced publications.

- IEC Just Published: [www.iec.ch/online\\_news/justpub](http://www.iec.ch/online_news/justpub)

Stay up to date on all new IEC publications. Just Published details twice a month all new publications released. Available on-line and also by email.

- Electropedia: [www.electropedia.org](http://www.electropedia.org)

The world's leading online dictionary of electronic and electrical terms containing more than 20 000 terms and definitions in English and French, with equivalent terms in additional languages. Also known as the International Electrotechnical Vocabulary online.

- Customer Service Centre: [www.iec.ch/webstore/custserv](http://www.iec.ch/webstore/custserv)

If you wish to give us your feedback on this publication or need further assistance, please visit the Customer Service Centre FAQ or contact us:

Email: [csc@iec.ch](mailto:csc@iec.ch)

Tel.: +41 22 919 02 11

Fax: +41 22 919 03 00

### A propos de la CEI

La Commission Electrotechnique Internationale (CEI) est la première organisation mondiale qui élabore et publie des normes internationales pour tout ce qui a trait à l'électricité, à l'électronique et aux technologies apparentées.

### A propos des publications CEI

Le contenu technique des publications de la CEI est constamment revu. Veuillez vous assurer que vous possédez l'édition la plus récente, un corrigendum ou amendement peut avoir été publié.

- Catalogue des publications de la CEI: [www.iec.ch/searchpub/cur\\_fut-f.htm](http://www.iec.ch/searchpub/cur_fut-f.htm)

Le Catalogue en-ligne de la CEI vous permet d'effectuer des recherches en utilisant différents critères (numéro de référence, texte, comité d'études,...). Il donne aussi des informations sur les projets et les publications retirées ou remplacées.

- Just Published CEI: [www.iec.ch/online\\_news/justpub](http://www.iec.ch/online_news/justpub)

Restez informé sur les nouvelles publications de la CEI. Just Published détaille deux fois par mois les nouvelles publications parues. Disponible en-ligne et aussi par email.

- Electropedia: [www.electropedia.org](http://www.electropedia.org)

Le premier dictionnaire en ligne au monde de termes électroniques et électriques. Il contient plus de 20 000 termes et définitions en anglais et en français, ainsi que les termes équivalents dans les langues additionnelles. Egalement appelé Vocabulaire Electrotechnique International en ligne.

- Service Clients: [www.iec.ch/webstore/custserv/custserv\\_entry-f.htm](http://www.iec.ch/webstore/custserv/custserv_entry-f.htm)

Si vous désirez nous donner des commentaires sur cette publication ou si vous avez des questions, visitez le FAQ du Service clients ou contactez-nous:

Email: [csc@iec.ch](mailto:csc@iec.ch)

Tél.: +41 22 919 02 11

Fax: +41 22 919 03 00

# INTERNATIONAL STANDARD

# NORME INTERNATIONALE



**Industrial communication networks – Profiles –  
Part 3: Functional safety fieldbuses – General rules and profile definitions**

**Réseaux de communication industriels – Profils –  
Partie 3: Bus de terrain de sécurité fonctionnelle – Règles générales et  
définitions de profils**

INTERNATIONAL  
ELECTROTECHNICAL  
COMMISSION

COMMISSION  
ELECTROTECHNIQUE  
INTERNATIONALE

PRICE CODE **XA**  
CODE PRIX

ICS 25.040.40; 35.100.05

ISBN 978-2-88912-810-5

## CONTENTS

FOREWORD.....	6
0 Introduction .....	8
0.1 General.....	8
0.2 Patent declaration .....	10
1 Scope.....	11
2 Normative references .....	11
3 Terms, definitions, symbols, abbreviated terms and conventions .....	13
3.1 Terms and definitions .....	13
3.1.1 Common terms and definitions .....	13
3.1.2 CPF 1: Additional terms and definitions .....	18
3.1.3 CPF 2: Additional terms and definitions .....	18
3.1.4 CPF 3: Additional terms and definitions .....	18
3.1.5 CPF 6: Additional terms and definitions .....	18
3.1.6 CPF 8: Additional terms and definitions .....	18
3.1.7 CPF 12: Additional terms and definitions .....	18
3.1.8 CPF 13: Additional terms and definitions .....	18
3.1.9 CPF 14: Additional terms and definitions .....	18
3.2 Symbols and abbreviated terms.....	19
3.2.1 Common symbols and abbreviated terms .....	19
3.2.2 CPF 1: Additional symbols and abbreviated terms .....	19
3.2.3 CPF 2: Additional symbols and abbreviated terms .....	19
3.2.4 CPF 3: Additional symbols and abbreviated terms .....	19
3.2.5 CPF 6: Additional symbols and abbreviated terms .....	20
3.2.6 CPF 8: Additional symbols and abbreviated terms .....	20
3.2.7 CPF 12: Additional symbols and abbreviated terms .....	20
3.2.8 CPF 13: Additional symbols and abbreviated terms .....	20
3.2.9 CPF 14: Additional symbols and abbreviated terms .....	20
4 Conformance.....	20
5 Basics of safety-related fieldbus systems .....	21
5.1 Safety function decomposition .....	21
5.2 Communication system .....	21
5.2.1 General .....	21
5.2.2 IEC 61158 fieldbuses .....	21
5.2.3 Communication channel types .....	22
5.2.4 Safety function response time.....	22
5.3 Communication errors .....	23
5.3.1 General .....	23
5.3.2 Corruption .....	23
5.3.3 Unintended repetition .....	23
5.3.4 Incorrect sequence .....	23
5.3.5 Loss .....	24
5.3.6 Unacceptable delay .....	24
5.3.7 Insertion .....	24
5.3.8 Masquerade .....	24
5.3.9 Addressing .....	24
5.4 Deterministic remedial measures.....	24

5.4.1	General .....	24
5.4.2	Sequence number .....	25
5.4.3	Time stamp .....	25
5.4.4	Time expectation .....	25
5.4.5	Connection authentication .....	25
5.4.6	Feedback message .....	25
5.4.7	Data integrity assurance .....	25
5.4.8	Redundancy with cross checking .....	25
5.4.9	Different data integrity assurance systems .....	26
5.5	Relationships between errors and safety measures .....	26
5.6	Data integrity considerations .....	27
5.6.1	Calculation of the residual error rate .....	27
5.6.2	Residual error rate and SIL .....	29
5.7	Relationship between functional safety and security .....	29
5.8	Boundary conditions and constraints .....	30
5.8.1	Electrical safety .....	30
5.8.2	Electromagnetic compatibility (EMC) .....	30
5.9	Installation guidelines .....	30
5.10	Safety manual .....	30
5.11	Safety policy .....	30
6	Communication Profile Family 1 (FOUNDATION™ Fieldbus) – Profiles for functional safety .....	31
6.1	Functional Safety Communication Profile 1/1 .....	31
6.2	Technical overview .....	31
7	Communication Profile Family 2 (CIP™) – Profiles for functional safety .....	32
7.1	Functional Safety Communication Profile 2/1 .....	32
7.2	Technical overview .....	32
8	Communication Profile Family 3 (PROFIBUS™, PROFINET™) – Profiles for functional safety .....	34
8.1	Functional Safety Communication Profile 3/1 .....	34
8.2	Technical overview .....	34
9	Communication Profile Family 6 (INTERBUS®) – Profiles for functional safety .....	36
9.1	Functional Safety Communication Profile 6/7 .....	36
9.2	Technical overview .....	37
10	Communication Profile Family 8 (CC-Link™) – Profiles for functional safety .....	38
10.1	Functional Safety Communication Profile 8/1 .....	38
10.2	Technical overview .....	38
11	Communication Profile Family 12 (EtherCAT™) – Profiles for functional safety .....	39
11.1	Functional Safety Communication Profile 12/1 .....	39
11.2	Technical overview .....	39
12	Communication Profile Family 13 (Ethernet POWERLINK™) – Profiles for functional safety .....	40
12.1	Functional Safety Communication Profile 13/1 .....	40
12.2	Technical overview .....	40
13	Communication Profile Family 14 (EPA®) – Profiles for functional safety .....	41
13.1	Functional Safety Communication Profile 14/1 .....	41
13.2	Technical overview .....	42
Annex A (informative)	Example functional safety communication models .....	43

A.1 General .....	43
A.2 Model A .....	43
A.3 Model B .....	43
A.4 Model C .....	44
A.5 Model D .....	44
Annex B (informative) A safety communication channel model using CRC-based error checking .....	46
B.1 Overview .....	46
B.2 Channel model for calculations .....	46
B.3 Cyclic redundancy checking .....	47
B.3.1 General .....	47
B.3.2 Considerations concerning CRC polynomials .....	49
Annex C (informative) Structure of technology-specific parts .....	51
Annex D (informative) Assessment guideline .....	53
D.1 Overview .....	53
D.2 Channel types .....	53
D.2.1 General .....	53
D.2.2 Black channel .....	53
D.2.3 White channel .....	53
D.3 Data integrity considerations for white channel approaches .....	54
D.3.1 General .....	54
D.3.2 Model B and C .....	54
D.3.3 Model A and D .....	55
D.4 Verification of safety measures .....	55
D.4.1 General .....	55
D.4.2 Implementation .....	56
D.4.3 "De-energize to trip" principle .....	56
D.4.4 Safe state .....	56
D.4.5 Transmission errors .....	56
D.4.6 Safety reaction and response times .....	56
D.4.7 Combination of measures .....	56
D.4.8 Absence of interference .....	57
D.4.9 Additional fault causes (white channel) .....	57
D.4.10 Reference test beds and operational conditions .....	57
D.4.11 Conformance tester .....	57
Bibliography .....	58
Table 1 – Overview of the effectiveness of the various measures on the possible errors .....	27
Table 2 – Definition of items used for calculation of the residual error rate .....	28
Table 3 – Relationship of residual error rate to SIL level .....	29
Table 4 – Overview of profile identifier usable for FSCP 6/7 .....	37
Table B.1 – Example dependency $d_{min}$ and block length $n$ .....	49
Table C.1 – Common subclause structure for technology-specific parts .....	51

Figure 1 – Relationships of IEC 61784-3 with other standards (machinery) .....	8
Figure 2 – Relationships of IEC 61784-3 with other standards (process).....	9
Figure 3 – Safety communication as a part of a safety function .....	21
Figure 4 – Example model of a functional safety communication system .....	22
Figure 5 – Example of safety function response time components.....	23
Figure 6 – Example application .....	29
Figure 7 – Scope of FSCP 1/1 .....	32
Figure 8 – Relationship of Safety Validators .....	33
Figure 9 – Basic communication preconditions for FSCP 3/1 .....	35
Figure 10 – Structure of a FSCP 3/1 safety PDU.....	35
Figure 11 – Safe communication modes.....	36
Figure 12 – FSCP 6/7 communication preconditions .....	37
Figure 13 – Basic FSCP 12/1 system.....	39
Figure 14 – Producer consumer example .....	41
Figure 15 – Client server example .....	41
Figure 16 – FSCP 14/1 safety communication architecture.....	42
Figure A.1 – Model A .....	43
Figure A.2 – Model B .....	44
Figure A.3 – Model C .....	44
Figure A.4 – Model D .....	45
Figure B.1 – Communication channel with perturbation.....	46
Figure B.2 – Binary symmetric channel (BSC).....	47
Figure B.3 – Example of a block with message and CRC bits (redundancy code).....	48
Figure B.4 – Block codes for error detection .....	48
Figure B.5 – Proper and improper CRC polynomials .....	49
Figure D.1 – Basic Markov model .....	55

## INTERNATIONAL ELECTROTECHNICAL COMMISSION

**INDUSTRIAL COMMUNICATION NETWORKS –  
PROFILES –****Part 3: Functional safety fieldbuses –  
General rules and profile definitions**

## FOREWORD

- 1) The International Electrotechnical Commission (IEC) is a worldwide organization for standardization comprising all national electrotechnical committees (IEC National Committees). The object of IEC is to promote international co-operation on all questions concerning standardization in the electrical and electronic fields. To this end and in addition to other activities, IEC publishes International Standards, Technical Specifications, Technical Reports, Publicly Available Specifications (PAS) and Guides (hereafter referred to as “IEC Publication(s)”). Their preparation is entrusted to technical committees; any IEC National Committee interested in the subject dealt with may participate in this preparatory work. International, governmental and non-governmental organizations liaising with the IEC also participate in this preparation. IEC collaborates closely with the International Organization for Standardization (ISO) in accordance with conditions determined by agreement between the two organizations.
- 2) The formal decisions or agreements of IEC on technical matters express, as nearly as possible, an international consensus of opinion on the relevant subjects since each technical committee has representation from all interested IEC National Committees.
- 3) IEC Publications have the form of recommendations for international use and are accepted by IEC National Committees in that sense. While all reasonable efforts are made to ensure that the technical content of IEC Publications is accurate, IEC cannot be held responsible for the way in which they are used or for any misinterpretation by any end user.
- 4) In order to promote international uniformity, IEC National Committees undertake to apply IEC Publications transparently to the maximum extent possible in their national and regional publications. Any divergence between any IEC Publication and the corresponding national or regional publication shall be clearly indicated in the latter.
- 5) IEC itself does not provide any attestation of conformity. Independent certification bodies provide conformity assessment services and, in some areas, access to IEC marks of conformity. IEC is not responsible for any services carried out by independent certification bodies.
- 6) All users should ensure that they have the latest edition of this publication.
- 7) No liability shall attach to IEC or its directors, employees, servants or agents including individual experts and members of its technical committees and IEC National Committees for any personal injury, property damage or other damage of any nature whatsoever, whether direct or indirect, or for costs (including legal fees) and expenses arising out of the publication, use of, or reliance upon, this IEC Publication or any other IEC Publications.
- 8) Attention is drawn to the Normative references cited in this publication. Use of the referenced publications is indispensable for the correct application of this publication.

International Standard IEC 61784-3 has been prepared by subcommittee 65C: Industrial networks, of IEC technical committee 65: Industrial process measurement, control and automation.

This second edition cancels and replaces the first edition published in 2007. This edition constitutes a technical revision. The main changes with respect to the previous edition are listed below:

- clarifications and additional explanations for requirements, updated references;
- updates of definitions and requirements in relation with the new edition of IEC 61508;
- addition of a new informative Annex D providing an assessment guideline;
- updates in parts for CPF 1, CPF 2, CPF 3, CPF 6 (details provided in the parts);
- addition of new parts for CPF 8, CPF 12, CPF 13, CPF 14;
- in CPF parts, addition of an annex to provide information about test laboratories for testing and validating conformance of FSCP products.



This bilingual version published in 2011-12, corresponds to the English version published in 2010-07.

The text of this standard is based on the following documents:

FDIS	Report on voting
65C/591A/FDIS	65C/603/RVD

Full information on the voting for the approval of this standard can be found in the report on voting indicated in the above table.

The French version of this standard has not been voted upon.

This publication has been drafted in accordance with the ISO/IEC Directives, Part 2.

A list of all parts of the IEC 61784-3 series, published under the general title *Industrial communication networks – Profiles – Functional safety fieldbuses*, can be found on the IEC website.

The committee has decided that the contents of this publication will remain unchanged until the stability date indicated on the IEC web site under "<http://webstore.iec.ch>" in the data related to the specific publication. At this date, the publication will be

- reconfirmed,
- withdrawn,
- replaced by a revised edition, or
- amended.

<https://standards.iteh.ai/catalog/standards/sist/a5376a53-fac4-46df-9d0b-ba2e8cb3a512/iec-61784-3-2010>

**IMPORTANT – The 'colour inside' logo on the cover page of this publication indicates that it contains colours which are considered to be useful for the correct understanding of its contents. Users should therefore print this document using a colour printer.**

## 0 Introduction

### 0.1 General

The IEC 61158 fieldbus standard together with its companion standards IEC 61784-1 and IEC 61784-2 defines a set of communication protocols that enable distributed control of automation applications. Fieldbus technology is now considered well accepted and well proven. Thus many fieldbus enhancements are emerging, addressing not yet standardized areas such as real time, safety-related and security-related applications.

This standard explains the relevant principles for functional safety communications with reference to IEC 61508 series and specifies several safety communication layers (profiles and corresponding protocols) based on the communication profiles and protocol layers of IEC 61784-1, IEC 61784-2 and the IEC 61158 series. It does not cover electrical safety and intrinsic safety aspects.

Figure 1 shows the relationships between this standard and relevant safety and fieldbus standards in a machinery environment.

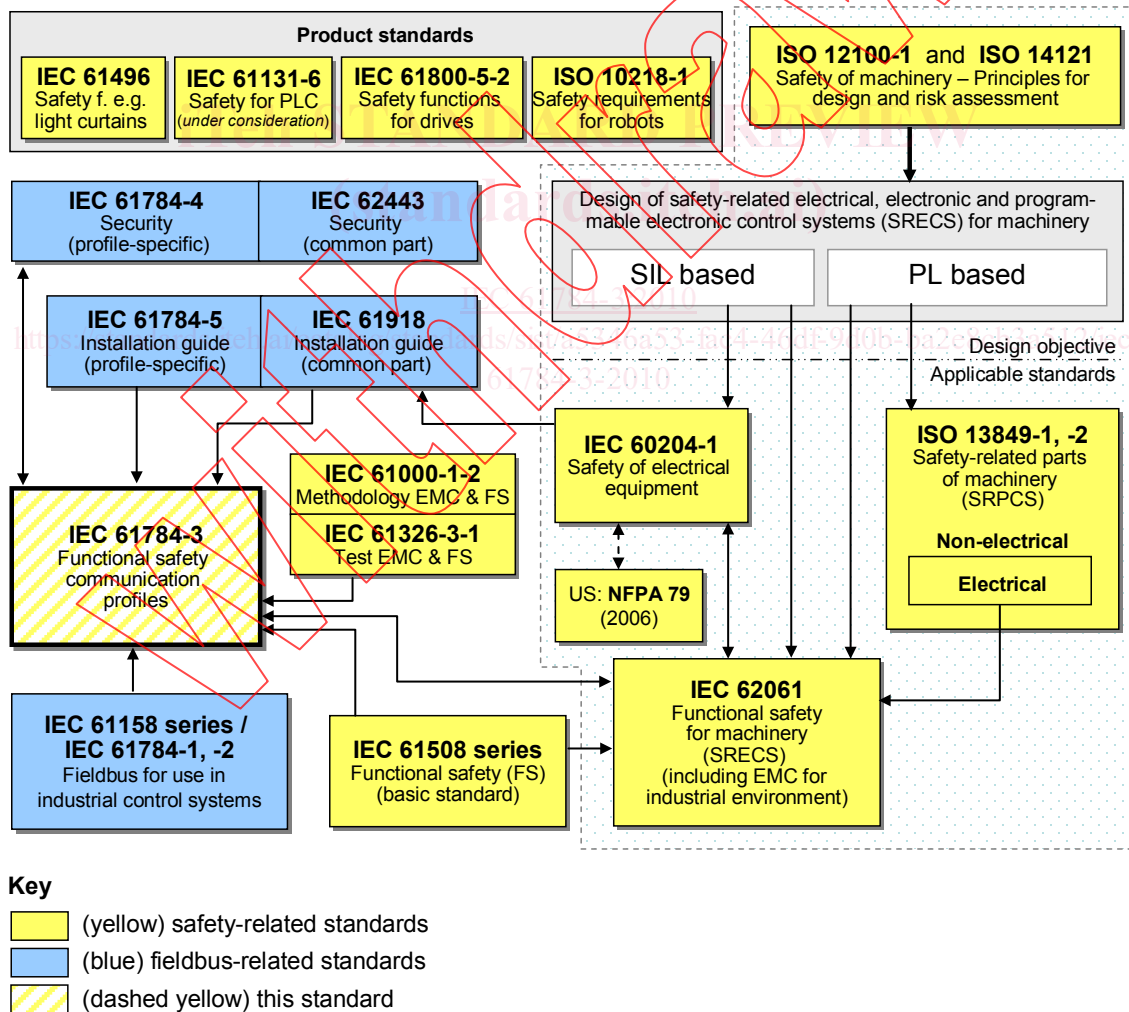

NOTE Subclauses 6.7.6.4 (high complexity) and 6.7.8.1.6 (low complexity) of IEC 62061 specify the relationship between PL (Category) and SIL.

**Figure 1 – Relationships of IEC 61784-3 with other standards (machinery)**

Figure 2 shows the relationships between this standard and relevant safety and fieldbus standards in a process environment.

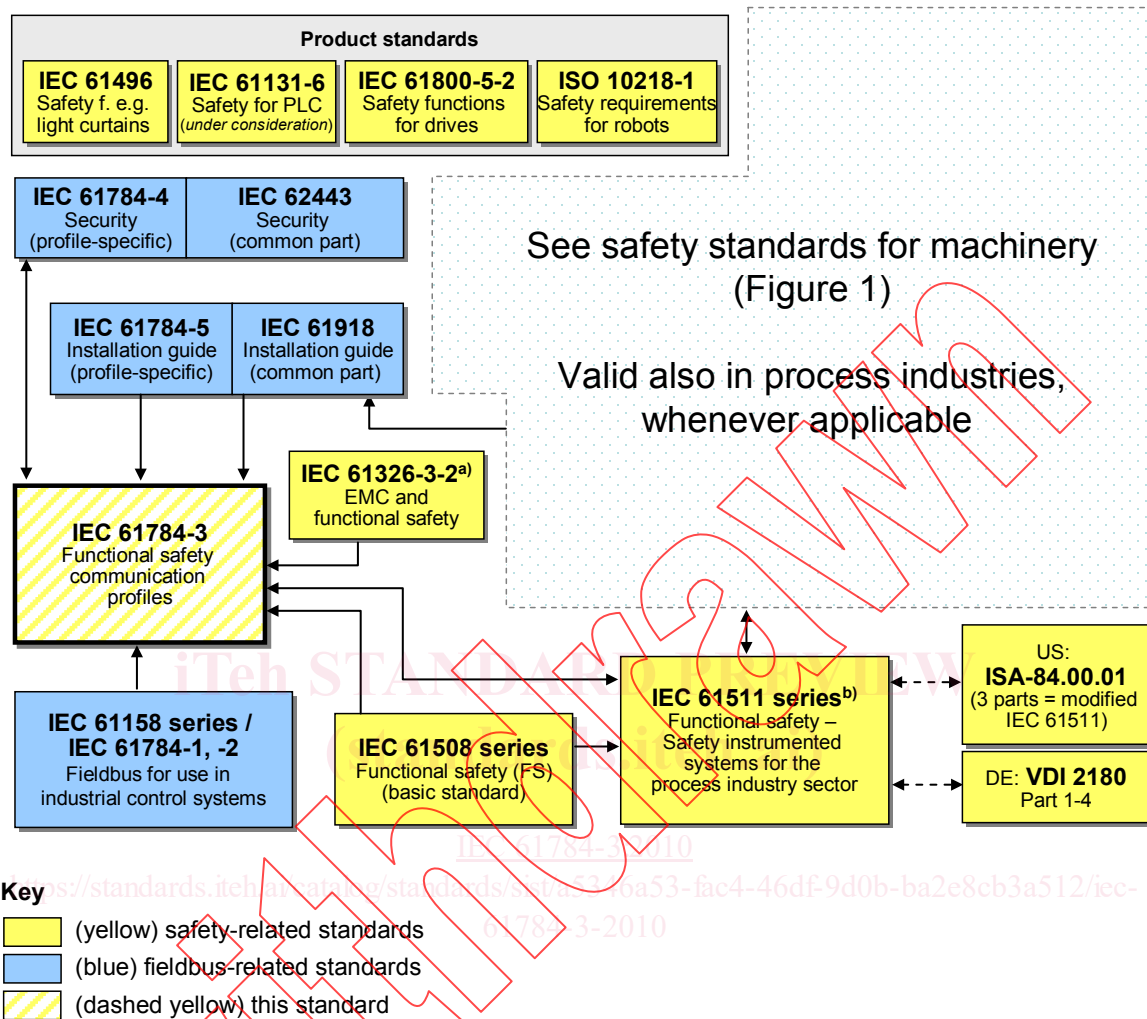

<sup>a</sup> For specified electromagnetic environments; otherwise IEC 61326-3-1.

<sup>b</sup> EN ratified.

**Figure 2 – Relationships of IEC 61784-3 with other standards (process)**

Safety communication layers which are implemented as parts of safety-related systems according to IEC 61508 series provide the necessary confidence in the transportation of messages (information) between two or more participants on a fieldbus in a safety-related system, or sufficient confidence of safe behaviour in the event of fieldbus errors or failures.

Safety communication layers specified in this standard do this in such a way that a fieldbus can be used for applications requiring functional safety up to the Safety Integrity Level (SIL) specified by its corresponding functional safety communication profile.

The resulting SIL claim of a system depends on the implementation of the selected functional safety communication profile within this system – implementation of a functional safety communication profile in a standard device is not sufficient to qualify it as a safety device.

This standard describes:

- basic principles for implementing the requirements of IEC 61508 series for safety-related data communications, including possible transmission faults, remedial measures and considerations affecting data integrity;
- individual description of functional safety profiles for several communication profile families in IEC 61784-1 and IEC 61784-2;
- safety layer extensions to the communication service and protocols sections of the IEC 61158 series.

## 0.2 Patent declaration

The International Electrotechnical Commission (IEC) draws attention to the fact that it is claimed that compliance with this document may involve the use of patents concerning functional safety communication profiles for families 1, 2, 3, 6, 12, 13 and 14 given in IEC 61784-3-1, IEC 61784-3-2, IEC 61784-3-3, IEC 61784-3-6, IEC 61784-3-12, IEC 61784-3-13 and IEC 61784-3-14.

IEC takes no position concerning the evidence, validity and scope of these patent rights.

The holders of these patent rights have assured IEC that they are willing to negotiate licences under reasonable and non-discriminatory terms and conditions with applicants throughout the world. In this respect, the statements of the holders of these patent rights are registered with IEC.

NOTE Patent details and corresponding contact information are provided in IEC 61784-3-1, IEC 61784-3-2, IEC 61784-3-3, IEC 61784-3-6, IEC 61784-3-12, IEC 61784-3-13 and IEC 61784-3-14.

<https://standards.iteh.ai/catalog/standards/sist/a5376a53-fac4-46df-9d0b-ba2e8cb3a512/iec-61784-3-2010>

## INDUSTRIAL COMMUNICATION NETWORKS – PROFILES –

### Part 3: Functional safety fieldbuses – General rules and profile definitions

#### 1 Scope

This part of the IEC 61784-3 series explains some common principles that can be used in the transmission of safety-relevant messages among participants within a distributed network using fieldbus technology in accordance with the requirements of IEC 61508 series<sup>1</sup> for functional safety. These principles can be used in various industrial applications such as process control, manufacturing automation and machinery.

This part<sup>2</sup> and the IEC 61784-3-x parts specify several functional safety communication profiles based on the communication profiles and protocol layers of the fieldbus technologies in IEC 61784-1, IEC 61784-2 and the IEC 61158 series.

NOTE 1 Other safety-related communication systems meeting the requirements of IEC 61508 series may exist that are not included in this standard.

NOTE 2 It does not cover electrical safety and intrinsic safety aspects. Electrical safety relates to hazards such as electrical shock. Intrinsic safety relates to hazards associated with potentially explosive atmospheres.

All systems are exposed to unauthorized access at some point of their life cycle. Additional measures need to be considered in any safety-related application to protect fieldbus systems against unauthorized access. The IEC 62443 series will address many of these issues; the relationship with the IEC 62443 series is detailed in a dedicated subclause of this part.

NOTE 3 Additional profile specific requirements for security may also be specified in IEC 61784-4<sup>3</sup> [10].

NOTE 4 Implementation of a functional safety communication profile according to this part in a device is not sufficient to qualify it as a safety device, as defined in IEC 61508 series.

NOTE 5 The resulting SIL claim of a system depends on the implementation of the selected functional safety communication profile within this system.

#### 2 Normative references

The following referenced documents are indispensable for the application of this document. For dated references, only the edition cited applies. For undated references, the latest edition of the referenced document (including any amendments) applies.

IEC 61131-2, *Programmable controllers – Part 2: Equipment requirements and tests*

IEC 61158 (all parts), *Industrial communication networks – Fieldbus specifications*

IEC 61326-3-1, *Electrical equipment for measurement, control and laboratory use – EMC requirements – Part 3-1: Immunity requirements for safety-related systems and for equipment intended to perform safety-related functions (functional safety) – General industrial applications*

<sup>1</sup> In the following pages of this standard, “IEC 61508” will be used for “IEC 61508 series”.

<sup>2</sup> In the following pages of this standard, “this part” will be used for “this part of the IEC 61784-3 series”.

<sup>3</sup> Proposed new work item under consideration.

IEC 61326-3-2, *Electrical equipment for measurement, control and laboratory use – EMC requirements – Part 3-2: Immunity requirements for safety-related systems and for equipment intended to perform safety-related functions (functional safety) – Industrial applications with specified electromagnetic environment*

IEC 61508 (all parts), *Functional safety of electrical/electronic/programmable electronic safety-related systems*

IEC 61508-1:2010<sup>4</sup>, *Functional safety of electrical/electronic/programmable electronic safety-related systems – Part 1: General requirements*

IEC 61508-2, *Functional safety of electrical/electronic/programmable electronic safety-related systems – Part 2: Requirements for electrical/electronic/programmable electronic safety-related systems*

IEC 61784-1, *Industrial communication networks – Profiles – Part 1: Fieldbus profiles*

IEC 61784-2, *Industrial communication networks – Profiles – Part 2: Additional fieldbus profiles for real-time networks based on ISO/IEC 8802-3*

IEC 61784-3-1, *Industrial communication networks – Profiles – Part 3-1: Functional safety fieldbuses – Additional specifications for CPF 1*

IEC 61784-3-2, *Industrial communication networks – Profiles – Part 3-2: Functional safety fieldbuses – Additional specifications for CPF 2*

IEC 61784-3-3, *Industrial communication networks – Profiles – Part 3-3: Functional safety fieldbuses – Additional specifications for CPF 3*

IEC 61784-3-6, *Industrial communication networks – Profiles – Part 3-6: Functional safety fieldbuses – Additional specifications for CPF 6*

IEC 61784-3-8<sup>5</sup>, *Industrial communication networks – Profiles – Part 3-8: Functional safety fieldbuses – Additional specifications for CPF 8*

IEC 61784-3-12<sup>5</sup>, *Industrial communication networks – Profiles – Part 3-12: Functional safety fieldbuses – Additional specifications for CPF 12*

IEC 61784-3-13<sup>5</sup>, *Industrial communication networks – Profiles – Part 3-13: Functional safety fieldbuses – Additional specifications for CPF 13*

IEC 61784-3-14<sup>5</sup>, *Industrial communication networks – Profiles – Part 3-14: Functional safety fieldbuses – Additional specifications for CPF 14*

IEC 61784-5 (all parts), *Industrial communication networks – Profiles – Part 5: Installation of fieldbuses – Installation profiles for CPF x*

IEC 61918, *Industrial communication networks – Installation of communication networks in industrial premises*

IEC 62280-1:2002, *Railway applications – Communication, signalling and processing systems – Part 1: Safety-related communication in closed transmission systems*

<sup>4</sup> To be published.

<sup>5</sup> To be published.

### 3 Terms, definitions, symbols, abbreviated terms and conventions

#### 3.1 Terms and definitions

For the purposes of this document, the following terms and definitions apply.

##### 3.1.1 Common terms and definitions

###### 3.1.1.1

###### **absolute time stamp**

*time stamp* referenced to a global time which is common for a group of devices using a *fieldbus*

[IEC 62280-2, modified]

###### 3.1.1.2

###### **availability**

probability for an automated system that for a given period of time there are no unsatisfactory system conditions such as loss of production

###### 3.1.1.3

###### **black channel**

*communication channel* without available evidence of design or validation according to IEC 61508

###### 3.1.1.4

###### **bridge**

abstract device that connects multiple network segments along the data link layer

###### 3.1.1.5

###### **communication channel**

logical connection between two end-points within a *communication system*

###### 3.1.1.6

###### **communication system**

arrangement of hardware, software and propagation media to allow the transfer of *messages* (ISO/IEC 7498 application layer) from one application to another

###### 3.1.1.7

###### **connection**

logical binding between two application objects within the same or different devices

###### 3.1.1.8

###### **Cyclic Redundancy Check (CRC)**

<value> redundant data derived from, and stored or transmitted together with, a block of data in order to detect data corruption

<method> procedure used to calculate the redundant data

NOTE 1 Terms "CRC code" and "CRC signature", and labels such as CRC1, CRC2, may also be used in this standard to refer to the redundant data.

NOTE 2 See also [29], [30]<sup>6</sup>.

<sup>6</sup> Figures in square brackets refer to the bibliography.