

**SLOVENSKI STANDARD**  
**SIST EN 2911:2001****01-januar-2001**

---

**Aerospace series - Shank nuts, self-locking, in heat resisting steel FE-PA92HT (A286), silver plated - Classification: 1 100 MPa (at ambient temperature) / 650 °C**

Aerospace series - Shank nuts, self-locking, in heat resisting steel FE-PA92HT (A286), silver plated - Classification: 1 100 MPa (at ambient temperature) / 650 °C

Luft- und Raumfahrt - Einnientmuttern, selbstsichernd, aus hochwärmfestem Stahl FE-PA92HT (A286), versilbert - Klasse: 1 100 MPa (bei Raumtemperatur) / 650 °C

Série aérospatiale - Ecrous a sertir, a freinage interne, en acier résistant a chaud FE-PA92HT (A286), argentés - Classification: 1 100 MPa (a température ambiante) / 650 °C

[https://standards.iteh.ai/catalog/standards/sist/de6d3499-1118-4b2d-994c-](https://standards.iteh.ai/catalog/standards/sist/de6d3499-1118-4b2d-994c-fbc9c93eb6c2/sist-en-2911-2001)

[fb9c93eb6c2/sist-en-2911-2001](https://standards.iteh.ai/catalog/standards/sist/de6d3499-1118-4b2d-994c-fbc9c93eb6c2/sist-en-2911-2001)

**Ta slovenski standard je istoveten z: EN 2911:1995**

**ICS:**

49.030.30      Matice      Nuts

**SIST EN 2911:2001**      en

**iTeh STANDARD PREVIEW**  
**(standards.iteh.ai)**

SIST EN 2911:2001

<https://standards.iteh.ai/catalog/standards/sist/de6d3499-1118-4b2d-994c-fbc9c93eb6c2/sist-en-2911-2001>

EUROPEAN STANDARD

EN 2911

NORME EUROPÉENNE

EUROPÄISCHE NORM

July 1995

ICS 49.040.20

Descriptors: aircraft industry, self-locking nut, heat resistant steel, silver coating, classification, surface treatment, dimension, dimensional tolerance, designation

English version

**Aerospace series - Shank nuts, self-locking, in heat resisting steel FE-PA92HT (A286), silver plated - Classification: 1 100 MPa (at ambient temperature) / 650 °C**

Série aéronautique - Ecrous à sertir, à freinage interne, en acier résistant à chaud FE-PA92HT (A286), argentés - Classification: 1 100 MPa (à température ambiante) / 650 °C

Luft- und Raumfahrt - Einnietmuttern, selbstsichernd, aus hochwarmfestem Stahl FE-PA92HT (A286), versilbert - Klasse: 1 100 MPa (bei Raumtemperatur) / 650 °C

<https://standards.iteh.ai/catalog/standards/sist/de6d3499-1118-4b2d-994c-fbc9c93eb6c2/sist-en-2911-2001>

This European Standard was approved by CEN on 1995-03-18. CEN members are bound to comply with the CEN/CENELEC Internal Regulations which stipulate the conditions for giving this European Standard the status of a national standard without any alteration.

Up-to-date lists and bibliographical references concerning such national standards may be obtained on application to the Central Secretariat or to any CEN member.

The European Standards exist in three official versions (English, French, German). A version in any other language made by translation under the responsibility of a CEN member into its own language and notified to the Central Secretariat has the same status as the official versions.

CEN members are the national standards bodies of Austria, Belgium, Denmark, Finland, France, Germany, Greece, Iceland, Ireland, Italy, Luxembourg, Netherlands, Norway, Portugal, Spain, Sweden, Switzerland and United Kingdom.

## CEN

European Committee for Standardization  
Comité Européen de Normalisation  
Europäisches Komitee für Normung

Central Secretariat: rue de Stassart, 36 B-1050 Brussels

## Foreword

**iTeh STANDARD PREVIEW**

This European Standard has been prepared by the European Association of Aerospace Manufacturers (AECMA).

(standards.iteh.ai)

After inquiries and votes carried out in accordance with the rules of this Association, this Standard has successively received the approval of the National Associations and the Official Services of the member countries of AECMA, prior to its presentation to CEN.

This European Standard shall be given the status of a National Standard, either by publication of an identical text or by endorsement, at the latest by January 1996, and conflicting national standards shall be withdrawn at the latest by January 1996.

According to the CEN/CENELEC Internal Regulations, the following countries are bound to implement this European Standard: Austria, Belgium, Denmark, Finland, France, Germany, Greece, Iceland, Ireland, Italy, Luxembourg, Netherlands, Norway, Portugal, Spain, Sweden, Switzerland and the United Kingdom.

## 1 Scope

This standard specifies the characteristics of self-locking shank nuts in FE-PA92HT, silver plated, for aerospace applications.

Classification : 1 100 MPa <sup>1)</sup> / 650 °C <sup>2)</sup>

## 2 Normative references

This European Standard incorporates by dated or undated reference provisions from other publications. These normative references are cited at the appropriate places in the text and the publications are listed hereafter. For dated references, subsequent amendments to or revisions of any of these publications apply to this European Standard only when incorporated in it by amendment or revision. For undated references the latest edition of the publication referred to applies.

- ISO 5855-2 Aerospace - MJ threads - Part 2 : Limit dimensions for bolts and nuts
- EN 2399 Heat resisting steel FE-PA92-HT -  $R_m \geq 900$  MPa - Bars for forged bolts -  $D \leq 25$  mm - Aerospace series <sup>3)</sup>
- EN 2424 Aerospace series - Marking of aerospace products
- EN 2786 Aerospace series - Electrolytic silver plating of fasteners <sup>4)</sup>
- EN 3004 Aerospace series - Nuts, self-locking, in heat resisting steel FE-PA92HT (A286) - Classification : 1 100 MPa / 650 °C - Technical specification <sup>4)</sup>
- EN 3639 Aerospace series - Heat resisting alloy FE-PA2601 - Softened and cold worked - Wire for forged fasteners -  $D \leq 15$  mm -  $900 \text{ MPa} \leq R_m \leq 1\,100 \text{ MPa}$  <sup>4)</sup>

SIST EN 2911:2001

## 3 Required characteristics

### 3.1 Configuration - Dimensions - Tolerances - Masses

See figure 1 and table 1. Dimensions and tolerances are in millimetres. They apply after silver plating.

### 3.2 Materials

EN 2399 or EN 3639

### 3.3 Surface treatment

EN 2786

Thickness :

- external surfaces : 5  $\mu\text{m}$  to 15  $\mu\text{m}$  ;
- thread  $\geq$  MJ6 : 5  $\mu\text{m}$  min. on thread flanks ;
- thread MJ5 : shall show complete coverage, without thickness requirement.

1) Corresponds to the minimum tensile stress which the nut is able to withstand at ambient temperature without breaking or cracking when tested with a bolt of a higher strength class.

2) Maximum test temperature of the parts

3) Published as AECMA Standard at the date of publication of this standard

4) Published as AECMA Prestandard at the date of publication of this standard

6,3 / ( 1,6 / 3,2 ) Values apply before silver plating.  
Thread surface will be as achieved by normal methods of manufacture.  
Remove sharp edges 0,1 to 0,4

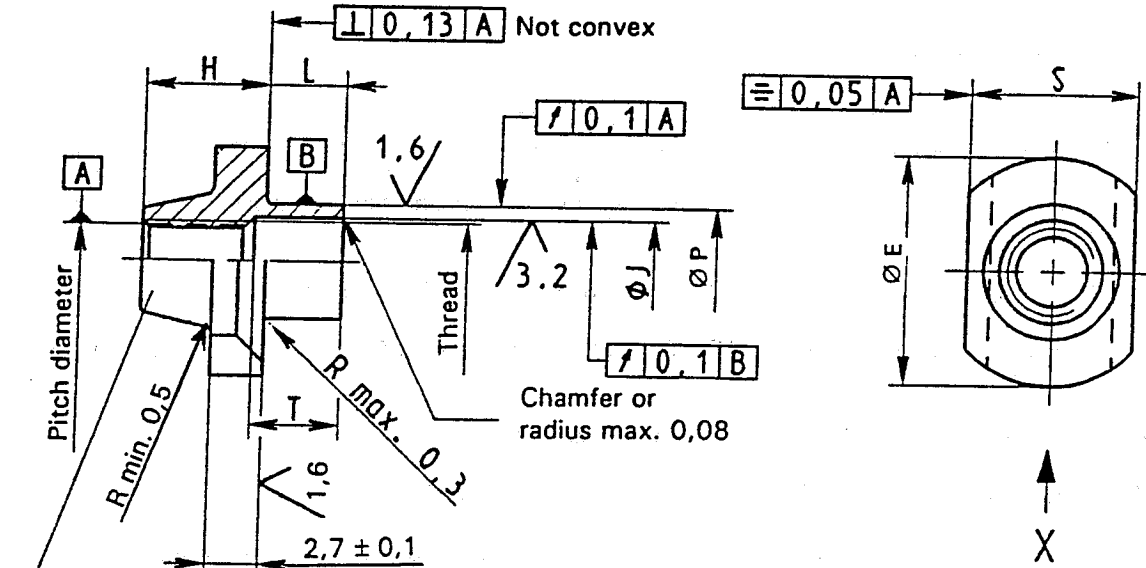

Form out-of-round in this area to achieve the self-locking requirement (tooling marks permissible).

**iTeh STANDARD PREVIEW**  
(standards.iteh.ai)

SIST EN 2911:2001

<https://standards.iteh.ai/catalog/standards/sist/de6d3499-1118-4b2d-994c-f1e9c93eb6e2/sist-en-2911-2001>

Marking in these areas but not in locking area

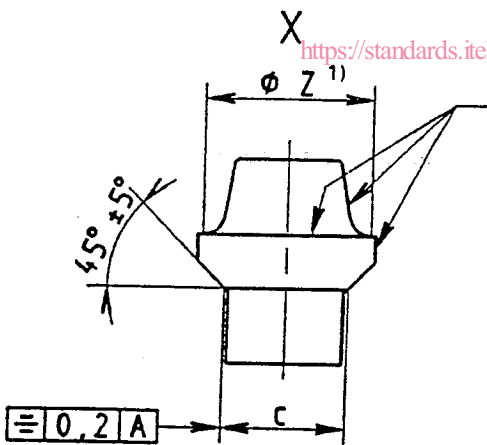

Details of form not stated are left to the manufacturer's discretion.

Figure 1

Table 1

Code	Thread <sup>1)</sup> Designation	C ± 0,1	E ± 0,25	H h14	J + 0,1 0	L		P O - 0,1	S ± 0,1	T ± 0,25	Z max.	Mass kg/1 000 parts ≈
						nom.	Tol.					
050	MJ5x0,8-4H6H	7	13	7	5,2	1,8	± 0,10	6,5	9,5	2,4	8,5	2,70
060	MJ6x1-4H5H	8	14	8	6,2			7,5	10,5		9,5	3,35
070	MJ7x1-4H5H	9	16	9	7,2	2,8	± 0,15	8,5	11,5	3,4	10,5	4,16
080	MJ8x1-4H5H	10	17	10	8,2	3,2		9,5	12,5	3,9	11,5	5,40

1) In accordance with ISO 5855-2. In the self-locking zone, the tolerances apply before forming out-of-round.

#### 4 Designation

EXAMPLE :

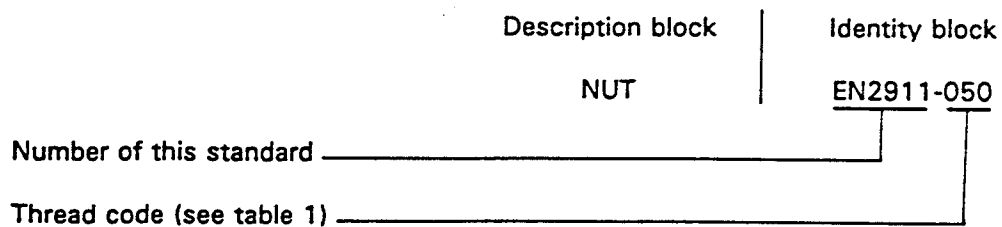

NOTE : If necessary, the code I9005 shall be placed between the description block and the identity block.

#### 5 Marking

EN 2424, style A, as indicated on figure 1.

#### 6 Technical specification

EN 3004

**iTeh STANDARD PREVIEW**  
**(standards.iteh.ai)**

SIST EN 2911:2001

<https://standards.iteh.ai/catalog/standards/sist/de6d3499-1118-4b2d-994c-fbc9c93eb6c2/sist-en-2911-2001>