

INTERNATIONAL
STANDARD

ISO
9151

First edition
1995-05-15

**Protective clothing against heat and
flame — Determination of heat
transmission on exposure to flame**
iTeh STANDARD PREVIEW
(standards.iteh.ai)

*Vêtements de protection contre la chaleur et les flammes —
Détermination de la transmission de chaleur à l'exposition d'une flamme*
ISO 9151:1995

<https://standards.iteh.ai/catalog/standards/sist/bd93399a-8e67-4452-b0db-2cf9935f4071/iso-9151-1995>



Reference number
ISO 9151:1995(E)

Contents

| | Page |
|--|------|
| 1 Scope | 1 |
| 2 Normative references | 1 |
| 3 Definitions | 1 |
| 4 Principle | 1 |
| 5 Apparatus | 1 |
| 6 Precautions | 4 |
| 7 Sampling | 4 |
| 8 Conditioning and testing atmospheres | 5 |
| 9 Test procedure | 5 |
| 10 Test report | 6 |

Annexes

| | |
|--|---|
| A Availability of materials | 7 |
| B Specimen test report form | 8 |
| C Significance of the heat transfer test | 9 |

iTeh STANDARD PREVIEW
(standards.iteh.ai)
<https://standards.iteh.ai/catalog/standards/sist/bd93399a-8e67-4452-b0db-2cf9935f4071/iso-9151-1995>
ISO 9151:1995

Foreword

ISO (the International Organization for Standardization) is a worldwide federation of national standards bodies (ISO member bodies). The work of preparing International Standards is normally carried out through ISO technical committees. Each member body interested in a subject for which a technical committee has been established has the right to be represented on that committee. International organizations, governmental and non-governmental, in liaison with ISO, also take part in the work. ISO collaborates closely with the International Electrotechnical Commission (IEC) on all matters of electrotechnical standardization.

Draft International Standards adopted by the technical committees are circulated to the member bodies for voting. Publication as an International Standard requires approval by at least 75 % of the member bodies casting a vote.

This International Standard (ISO 9151) was prepared by Technical Committee ISO/TC 94, *Personal safety – Protective clothing and equipment*, Subcommittee SC 13, *Protective clothing*.

This International Standard is equivalent to the European Standard EN 367:1992, *Protective clothing — Protection against heat and fire — Method of determining heat transmission on exposure to flame*.

Annexes A, B and C of this International Standard are for information only.

Introduction

This method has been developed from an American Society for Testing and Materials (ASTM) method which was based on the Du Pont thermal protective index (TPI) method. It has been considerably modified from previous versions following extensive interlaboratory trials carried out by ISO/TC 94/SC 13/WG 2.

Heat transmission through clothing is largely determined by its thickness including any air gaps trapped between the different layers. The air gaps can vary considerably in different areas of the same clothing assembly. The present method provides a grading of materials when tested under standard test conditions.

The following major modifications have been made from previous versions of this test method.

iTeh STANDARD PREVIEW

(Standards.IteH.ai)

- a) The air gap between the back of the test specimen and the calorimeter has been eliminated. This was found to increase all the values recorded, to provide a wider range of values and to distort the results with some materials more than others. [ISO 9151:1995](https://standards.iteh.ai/catalog/standards/sist/bd93399a-8e67-4452-b0db-2cd793317071/iso-9151-1995)
- b) The specimen size has been increased and the mass of the location plate has been specified. The mass of the location plate is used to hold the specimen in position so that the specimen is compressed by a standard mass and is also restricted from shrinking.
- c) The method of measuring the heat transmission has been drastically simplified and a new term "heat transfer index (HTI)" has been introduced to avoid confusion with the thermal protective index (TPI) or other terms used in previous versions of this test. This change makes it easier to perform the test and reduces the possibility of mathematical errors in calculating the results. The heat transfer index provides a method of grading materials which does not imply that the material tested will give any precise protection time under actual use conditions.
- d) Other methods of restraining the test specimens using clamps or pins have been rejected on the basis of interlaboratory trials because of practical difficulties which were believed to increase the interlaboratory variability.
- e) All terminology which implies that the test method measures the protection time provided by the test material has been eliminated. The protection provided under actual use conditions will vary considerably, depending on the severity of the actual flame source and the thickness of the clothing, including intermediate air gaps, in the exposed area.

Protective clothing against heat and flame — Determination of heat transmission on exposure to flame

1 Scope

This International Standard specifies a method for comparing the heat transmission through materials or material assemblies used in protective clothing. Materials are ranked by calculation of a heat transfer index, which is an indication of the relative heat transmission under the specified test conditions. The heat transfer index should not be taken as a measure of the protection time given by the tested materials under actual use conditions.

2 Normative references

The following standards contain provisions which, through reference in this text, constitute provisions of this International Standard. At the time of publication, the editions indicated were valid. All standards are subject to revision, and parties to agreements based on this International Standard are encouraged to investigate the possibility of applying the most recent editions of the standards indicated below. Members of IEC and ISO maintain registers of currently valid International Standards.

ISO 139:1973, *Textiles — Standard atmospheres for conditioning and testing*.

IEC 584-1:1977, *Thermocouples — Part 1: Reference tables*.

3 Definitions

For the purposes of this International Standard, the following definitions apply.

3.1 test specimen: All the layers of fabric or other materials arranged in the order and orientation as used in practice and including undergarments.

3.2 incident heat flux density: Amount of energy incident per unit time on the exposed face of the specimen, expressed in kilowatts per square metre (kW/m²).

3.3 heat transfer index (flame): Whole number calculated from the mean time in seconds to achieve a temperature rise of $(24 \pm 0,2)$ °C when testing by this method using a copper disc of mass $(18 \pm 0,05)$ g and a starting temperature of (25 ± 5) °C.

ISO 9151:1995

<https://standards.iteh.ai/catalog/standards/sist/bd93399a-8e67-4452-b0db-2cf9935f4071/iso-9151-1995>

4 Principle

A horizontally oriented test specimen is partially restrained from moving and subjected to an incident heat flux of 80 kW/m² from the flame of a gas burner placed beneath it. The heat passing through the specimen is measured by means of a small copper calorimeter on top of and in contact with the specimen.

The time, in seconds, for the temperature in the calorimeter to rise $(24 \pm 0,2)$ °C is recorded. The mean result for three test specimens is calculated as the "heat transfer index (flame)".

5 Apparatus

The apparatus consists of

- a gas burner;
- a copper disc calorimeter;
- a specimen support frame;
- a calorimeter location plate;

- a support stand;
- suitable measuring equipment;
- a template.

5.1 Gas burner.

A flat topped Meker burner with a perforated top area of (38 ± 2) mm diameter and a jet suitable for propane gas shall be used.

Commercial grade propane shall be used with the flow being controlled by a fine control valve and flowmeter.

5.2 Copper disc calorimeter, consisting of a disc of copper of at least 99 % purity, having a diameter of 40 mm and thickness 1,6 mm, and a mass of 18 g. The disc shall be accurately weighed before assembly.

A copper-constantan thermocouple, with an output in millivolts complying with IEC 584-1, is mounted on the copper disc as shown in figure 1. The constantan wire shall be attached to the centre of the disc and the copper wire shall be attached as near the circumference as possible but so as not to interfere with mounting the disc in the block. The diameter of both wires shall be 0,26 mm or less and only the length attached to the disc shall be bared.

The calorimeter is located in a mounting block which shall consist of a 89 mm diameter circular piece of asbestos-free noncombustible heat insulating board of nominal thickness 13 mm. The thermal characteristics shall comply with the following specification:

| | |
|----------------------|----------------------------------|
| Density | (750 ± 50) kg/m ³ |
| Thermal conductivity | $0,18$ W/(m·K) ± 10 % |

A circular cavity is machined in the centre of the block to accommodate the disc and an air gap, as shown in figure 2. The disc is bonded in position around its circumference with an adhesive capable of withstanding temperatures of about 200 °C. The face of the copper disc shall be flush with the surface of the mounting block. It shall also be coated with a thin layer of an optically black paint having a coefficient of absorption, α , greater than 0,9 (see annex A).

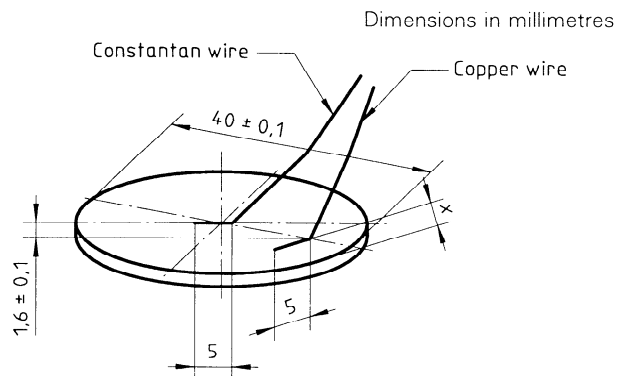

NOTES

- 1 $2 \text{ mm} \leq x \leq 5 \text{ mm}$ so as not to interfere with the seating of disc in the mounting block but still as near the edge as possible.
- 2 The wires shall be attached to the disc by soft solder using the minimum quantity necessary.

Figure 1 — Calorimeter

A copper-constantan thermocouple, with an output in millivolts complying with IEC 584-1, is mounted on the copper disc as shown in figure 1. The constantan wire shall be attached to the centre of the disc and the copper wire shall be attached as near the circumference as possible but so as not to interfere with mounting the disc in the block. The diameter of both wires shall be 0,26 mm or less and only the length attached to the disc shall be bared.

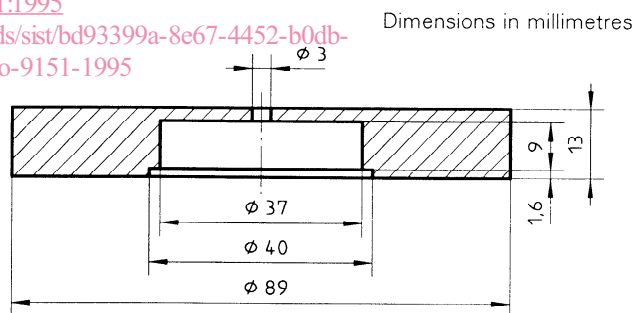

Construction material: Monolux 500 (cape boards) or equivalent.

Figure 2 — Calorimeter mounting block

5.3 Specimen support frame, consisting of a piece of copper 150 mm square and 1,6 mm thick with a 50 mm square hole in its centre (see figure 3).

5.4 Calorimeter location plate, made from a piece of aluminium 149 mm square and 6 mm thick and having a circular hole 90 mm in diameter located centrally (see figure 4). The plate shall weigh (264 ± 13) g.

5.5 Support stand, used to locate the specimen support frame relative to the burner. The top face of the specimen support frame shall be 50 mm above and parallel with the top face of the burner, with the axis of the burner aligned with the centre of the opening in the support frame (see figure 5).

It is convenient to have a shutter between the burner and the specimen support frame. The shutter shall open completely in less than 0,2 s and shall be operated immediately after placing the burner in position. It is useful if the positioning of the burner, or the opening of the shutter, if fitted, can be used to record the start of the exposure automatically.

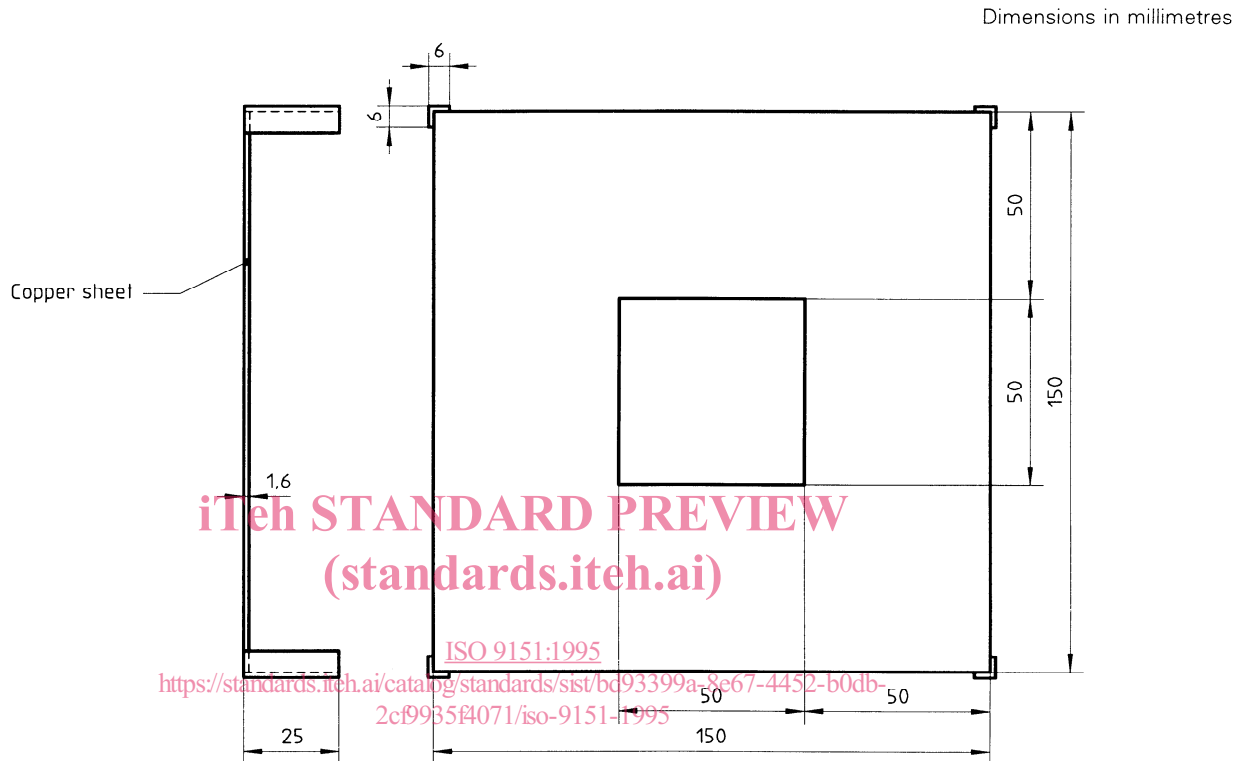

Figure 3 — Specimen support frame

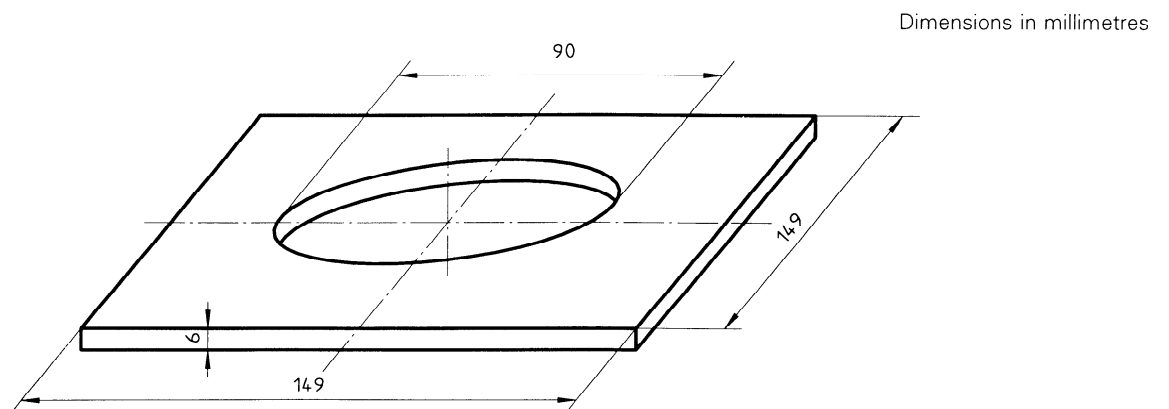

Figure 4 — Calorimeter location plate

Dimensions in millimetres

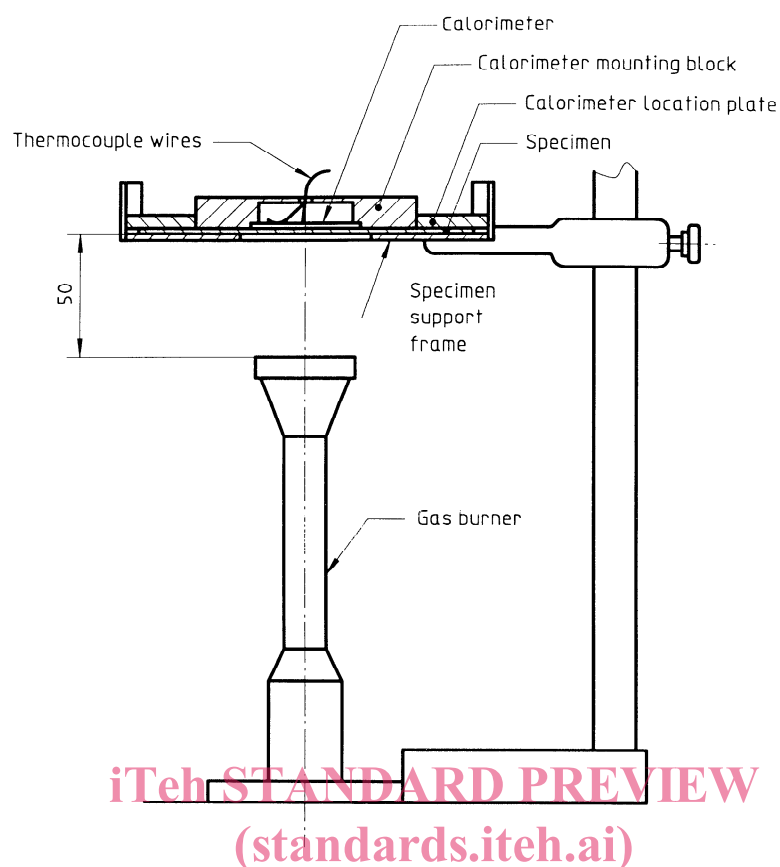

Figure 5 — Support stand

<https://standards.iteh.ai/catalog/standards/sist/bd93399a-8e67-4452-b0db-2cf9935f4071/iso-9151-1995>

5.6 Recorder.

To enable the absolute temperature of the copper disc to be determined, the thermocouple should be connected to either an ice junction or a commercial reference junction. The voltage signal from the thermocouple shall be connected to either a suitable potentiometric chart recorder or programmable data recorder. The recorder shall enable voltages to be read to 10 μV and times to 0,2 s.

5.7 Flat rigid template, with dimensions 140 mm \times 140 mm.

6 Precautions

Perform the test in a hood or ventilated area to carry away the fumes. It may be necessary to turn off the exhaust or to shield the apparatus during the test so as not to disturb the flame.

The equipment becomes hot during testing and some test materials may melt or drip. Use protective gloves when handling hot objects.

Keep combustible materials away from the burner. Ensure that the solvent used for cleaning the calorimeter is kept away from hot surfaces and naked flames.

7 Sampling

7.1 Specimen dimensions

The specimens shall have the dimensions 140 mm \times 140 mm and shall be taken from points more than 50 mm from the edge of the pieces of the material, in an area free from defects. Composite specimens shall reproduce the arrangement in which the layers are used in practice.

The specimen shall be marked out using the template (see 5.7).

7.2 Number of specimens

A minimum of three specimens shall be tested for each material or assembly of materials.

8 Conditioning and testing atmospheres

8.1 Conditioning atmosphere

Prior to testing, the specimens shall be conditioned for at least 24 h at a temperature of (20 ± 2) °C and a relative humidity of (65 ± 2) % (see ISO 139). If testing is not carried out immediately after conditioning, place the conditioned test specimens in a sealed container. Begin testing of each specimen within 3 min of removing it from the conditioning atmosphere or sealed container.

8.2 Testing atmosphere

Perform the tests in an atmosphere having a temperature of 10 °C to 30 °C and a relative humidity of 15 % to 80 % and which is free from draughts.

9 Test procedure

9.1 Preparation and calibration

9.1.1 Preliminary measures

Position the support frame on the support stand so that the top surface on which the specimen is placed is 50 mm above the top face of the burner. It is suggested that a guide and stops be used to enable the burner to be positioned quickly with its axis in line with the centre of the specimen.

Place the burner to one side, activate and ignite the gas supply, and allow several minutes for flame stabilization.

Connect the thermocouple to the cold junction, and connect the output voltage into the recording device.

Before every incident heat flux density regulation or specimen evaluation, the copper disc temperature should be in a relatively steady state and within ± 2 °C of ambient temperature. Cooling may be accelerated by the use of any dry, chilled heat sink, or by forced air draught. Alternatively, a number of calorimeter units may be rotated. Heating may be achieved by contact of the palm of the hand with the copper disc or by short exposure to the burner flame.

WARNING — On no account shall the calorimeter mounting block be allowed to come into contact with water. If this occurs accidentally it shall be dried out thoroughly before further use.

9.1.2 Regulation of the incident heat flux density

The gas flowrate and burner setting will vary with the individual combination used, and regulation of the settings for one or both will be necessary during initial installation and from time to time during testing. The correct flux should be achieved from a flame with clearly defined stable light blue cones firmly positioned on the burner grid with a large diffuse bluish flame above.

The flame setting is confirmed by measuring the heat flux density with the calorimeter.

Place the calorimeter location plate on the specimen support frame. Place the calorimeter in the hole in the locating plate with the copper disc facing downwards.

Select the required rate of travel of the recording device, and slide the burner quickly and deliberately under the calorimeter until it locates against its stops. If a shutter is used, open the shutter (see 5.5).

Allow the burner to remain in position for about 10 s.

Withdraw the burner or close the shutter.

The recorded output should show a short nonlinear temperature-time region just after the start of the exposure, followed by a linear region which continues until exposure ceases. Refer to standard thermocouple electromotive force tables to determine the rate of rise of temperature in degrees Celsius per second of this linear region. The heat flux density, Q (in kW/m²) is then determined from the following equation:

$$Q = \frac{M c_p R}{A}$$

where

- M is the mass of the copper disc in kilograms;
- c_p is the specific heat capacity of the copper [$= 0,385$ kJ/(kg·°C)];
- R is the rate of rise in disc temperature in the linear region in degrees Celsius per second;
- A is the disc area in square metres.

The heat flux density determined by this procedure shall be within ± 5 % of the specified 80 kW/m². Adjust the gas flowrate if required, and repeat until three consecutive values are obtained which fall within the required limits.