



SLOVENSKI STANDARD
SIST ISO 9191:1995

01-september-1995

Enoosni traktor - Tritočkovni priključni sistem

Lawn and garden ride-on (riding) tractors -- Three-point hitch

Tracteurs de jardin et de pelouse à conducteur porté -- Attelage trois points

Ta slovenski standard je istoveten z: ISO 9191:1991

[SIST ISO 9191:1995](https://standards.iteh.ai/catalog/standards/sist/e13a4a15-8ec4-4a14-8622-ed4c50cc379/sist-iso-9191-1995)

<https://standards.iteh.ai/catalog/standards/sist/e13a4a15-8ec4-4a14-8622-ed4c50cc379/sist-iso-9191-1995>

ICS:

65.060.70 Vrtnarska oprema Horticultural equipment

SIST ISO 9191:1995

en

iTeh STANDARD PREVIEW
(standards.iteh.ai)

[SIST ISO 9191:1995](#)

<https://standards.iteh.ai/catalog/standards/sist/e13a4a15-8ec4-4a14-8622-edc4c50cc379/sist-iso-9191-1995>

INTERNATIONAL STANDARD

ISO
9191

First edition
1991-03-01

Lawn and garden ride-on (riding) tractors — Three-point hitch

iTeh STANDARD PREVIEW
(standards.iteh.ai)

Tracteurs de jardin et de pelouse à conducteur porté — Attelage trois points

[SIST ISO 9191:1995](https://standards.iteh.ai/catalog/standards/sist/e13a4a15-8ec4-4a14-8622-edc4c50cc379/sist-iso-9191-1995)

<https://standards.iteh.ai/catalog/standards/sist/e13a4a15-8ec4-4a14-8622-edc4c50cc379/sist-iso-9191-1995>



Reference number
ISO 9191:1991(E)

Foreword

ISO (the International Organization for Standardization) is a worldwide federation of national standards bodies (ISO member bodies). The work of preparing International Standards is normally carried out through ISO technical committees. Each member body interested in a subject for which a technical committee has been established has the right to be represented on that committee. International organizations, governmental and non-governmental, in liaison with ISO, also take part in the work. ISO collaborates closely with the International Electrotechnical Commission (IEC) on all matters of electrotechnical standardization.

Draft International Standards adopted by the technical committees are circulated to the member bodies for voting. Publication as an International Standard requires approval by at least 75 % of the member bodies casting a vote.

International Standard ISO 9191 was prepared by Technical Committee ISO/TC 23, *Tractors and machinery for agriculture and forestry*.

Annex A of this International Standard is for information only.

<https://standards.iteh.ai/catalog/standards/sist/e13a4a15-8ec4-4a14-8622-edc4c50cc379/sist-iso-9191-1995>

© ISO 1991

All rights reserved. No part of this publication may be reproduced or utilized in any form or by any means, electronic or mechanical, including photocopying and microfilm, without permission in writing from the publisher.

International Organization for Standardization
Case Postale 56 • CH-1211 Genève 20 • Switzerland

Printed in Switzerland

Lawn and garden ride-on (riding) tractors — Three-point hitch

1 Scope

This International Standard specifies the requirements for the connection of implements or attachments to the rear of lawn and garden ride-on (riding) tractors by means of a three-point free link hitch in association with a power lift.

It applies to lawn and garden ride-on (riding) tractors as defined below.

2 Definitions

For the purposes of this International Standard, the following definitions apply.

2.1 ride-on (riding) machine; lawn and garden tractor; turf (riding) tractor: Self-propelled machine on which an operator rides, designed primarily for cutting grass and auxiliary garden work. The cutting means may be an integral part of the machine or suspended from or attached to the machine.¹⁾

2.2 attachment: Optional assembly of components that can be mounted on a lawn and garden ride-on (riding) tractor for a specific use.

2.3 General

2.3.1 linkage: Combination of one upper link and two lower links, each articulated to the tractor and the implement at opposite ends, in order to connect the implement to the tractor.

2.3.2 hitch point: Articulated connection between a line and the implement. For geometrical analysis, the hitch point is established as the centre of the articulated connection between a link and the implement.

2.3.3 link point: Articulated connection between a link and the tractor. For geometrical analysis, the link point is established as the centre of the articulated connection between a link and the tractor.

2.4 Linkage components (see figure 1 and figure 2)

2.4.1 upper link ①; lower link ②: Elements as appropriate in the linkage, each fitted with an articulated connection at both ends.

2.4.2 upper hitch point ③: Articulated connection between the upper link and the implement.

2.4.3 upper link point ⑤: Articulated connection between an upper link and the tractor.

2.4.4 lower hitch point ④: Articulated connection between a lower link and the implement.

2.4.5 lower link point ⑥: Articulated connection between a lower link and the tractor.

2.4.6 upper hitch pin ⑦: Pin, usually detachable and forming part of the upper link assembly, that connects the upper link to the implement.

2.4.7 lower hitch stud or pin ⑧: Stud or pin attached to the implement, on which a lower link is secured.

2.4.8 mast ⑨: Member that provides attachment of the upper link of the implement.

2.4.9 lift linkage: Connecting linkage that transmits force to the lower links for raising and lowering implements.

1) For the convenience of the user of this International Standard, this definition is repeated from ISO 5395:1990 (definition 1.3.40).

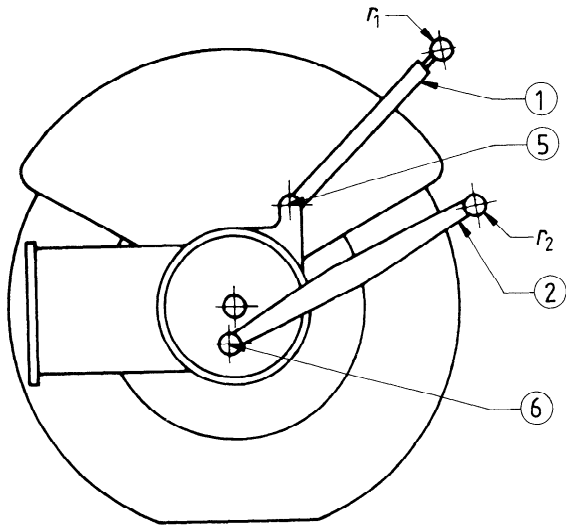

Figure 1 — Tractor linkage

Table 1 — Implement dimensions

Dimensions in millimetres

Symbol	Measurement	Dimension	
		min.	max.
Upper hitch point:			
b_1	Width inside	27	—
b_2	Width outside	—	49
r_1	Clearance radius for upper link	38	—
d_1	Hitch pin hole diameter	17	18
Lower hitch point:			
d_2	Stud (hitch pin) diameter	15	16
l_1	Linchpin hole distance	37	—
d_3	Linchpin hole diameter	6	8
l_2	Lower hitch point span	500	508
r_2	Clearance radius for lower link	50	—
—	Implement encroachment in front of lower hitch point if implement extends laterally behind tyre	—	13
h_1	Implement mast height (see 3.3)	—	305

iTeh STANDARD PREVIEW
(standards.iteh.ai)

SIST ISO 9191:1995

<https://standards.iteh.ai/catalog/standards/sist/e13a4a15-8ec4-4a14-8622-edc4c50cc379/sist-iso-9191-1995>

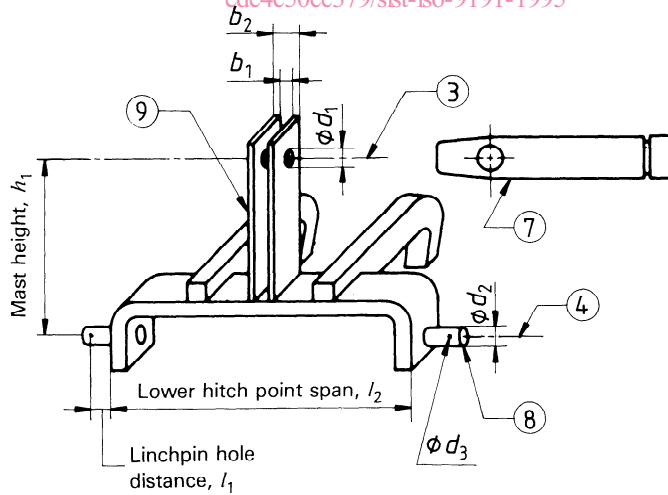

Figure 2 — Implement hitch

2.5 Linkage dimensions (see figure 3)

2.5.1 mast height: Perpendicular distance between the upper hitch point and common axis of the lower hitch points.

2.5.2 levelling adjustment: Adjustment of lower links so that the one lower hitch point may be moved vertically with respect to the other lower hitch point to provide an inclination of the implement.

2.5.3 lower hitch point span: Distance between lower hitch points measured at the base of the lower hitch stud, or the distance between the innermost restraining means provided on the implement.

2.5.4 linchpin hole distance: Distance between the linchpin hole centreline and the lower link stud base.

2.5.5 lift range: Range of movement of the lower hitch points using the extent of manual adjustment provided in the lift linkage in conjunction with the power range, expressed as the maximum and minimum possible heights of the lower hitch points above ground level, the lower hitch point axis being maintained horizontal to the ground.

2.5.6 power range: Total vertical movement of the lower hitch point excluding any adjustment in the linkage or lift linkage.

2.5.7 lower hitch point tyre clearance: Clearance expressed as a radial dimension from the lower hitch point to the outside diameter of the tyre with the implement in any position and all side-sway eliminated from the links.

2.5.8 lower hitch point tractor clearance: Horizontal dimension between the rearmost parts of the tractor in the area between the two draft links and the horizontal line through the two lower hitch points throughout the range of vertical movement of the hitch points. (See figure 4.)

2.5.9 mast adjustment: Usable range of movement of the mast in a vertical plane. It is measured as the maximum and minimum heights of the lower hitch points above the ground between which a mast of standard height can be adjusted to any inclination between vertical and 5° from vertical rearwards. Adjustment of the mast controls the pitch of the implement.

NOTE 1 Specifying the mast adjustment to be provided enables the tractor designer to determine the minimum acceptable top link length adjustment in relation to the lower linkage attachment points. It also permits the implement manufacturer to determine the range over which pitch adjustment can be obtained.

3 Dimensions

3.1 Implements

Dimensions relating to the implement shall be as given in figure 2 and table 1.

3.2 Tractor

Dimensions relating to the tractor shall be as given in figure 3 and table 2.

The values for lift range, power range and adjustments shall be as given in table 3.

3.3 Mast height

The mast height is not necessarily a mechanical dimension on the implement itself. It is a figure used in design and if properly used for design of both implement and tractor, a suitably interchangeable implement/tractor combination will be achieved. This International Standard makes it possible to produce tractors and implements that will give good performance in any combination; therefore, consideration of linkage geometry is essential. This makes it desirable to establish a standard mast height and a standard mast adjustment within a working range, because these items influence the position of hitch points that are common to both the implement and the tractor.

Mast height is one of the essential factors in establishing the virtual hitch point of the free-link system, draft signal for the draft-responsive system, loads on the linkage and hitch points, changes in implement pitch corresponding to changes in working depth, implement pitch when the implement is ready for transport, clearance of the implement with the tractor, especially ready for transport, and clearance of the hitch links with the implement or with the tractor, especially ready for transport.

When an implement mast height other than standard is chosen, to achieve some specific performance feature, care should be taken to ensure that the desired performance is secured with tractors likely to operate the implement.

4 Tractor lift force capacity

A minimum lift force of 2 kN shall be available at a distance of 305 mm to the rear of the lower hitch point and throughout the power range using 80 % of the minimum hydraulic relief valve pressure setting.

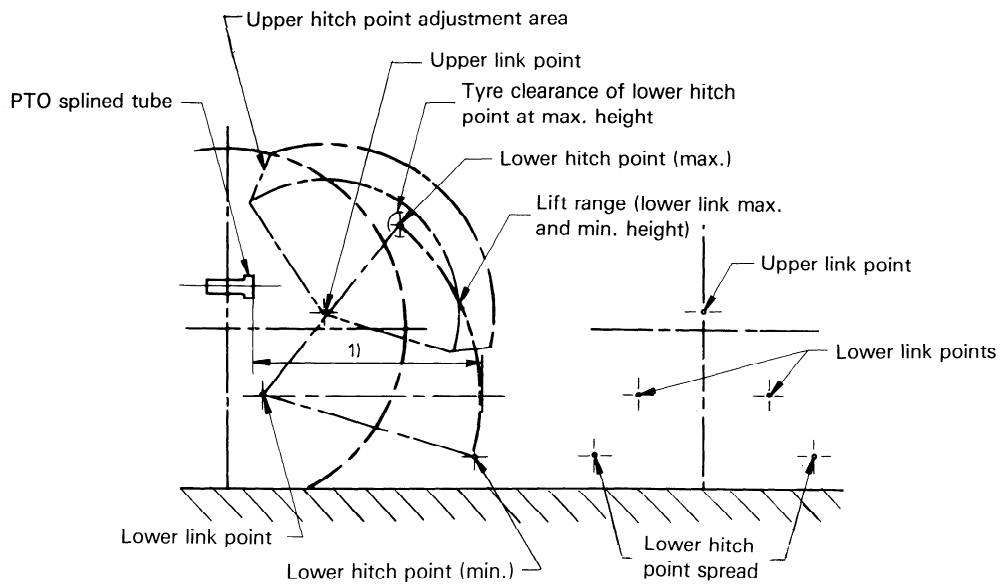

1) Horizontal distance from PTO splined tube to lower hitch point with lower link horizontal (see ISO 9123).

Figure 3 — Tractor dimensions

iTeh STANDARD PREVIEW
(standards.iteh.ai)

[SIST ISO 9191:1995](https://standards.iteh.ai/catalog/standards/sist/e13a4a15-8ec4-4a14-8622-edc4c50cc379/sist-iso-9191-1995)

<https://standards.iteh.ai/catalog/standards/sist/e13a4a15-8ec4-4a14-8622-edc4c50cc379/sist-iso-9191-1995>

Table 2 — Tractor dimensions

Dimensions in millimetres

Measurement	Dimension	
	min.	max.
Upper link:		
Width at hitch point	—	26
Radius at hitch point	—	25
Hitch pin hole diameter	17	18
Side-sway at hitch point ¹⁾		
Upper hitch pin:		
Diameter	15	16
Distance from head to centreline of linchpin hole	54	—
Linchpin hole diameter	6	8
Lower link:		
Width at hitch point	—	26
Radius at hitch point	—	40
Stud (hitch pin) hole diameter	17	18
Lower hitch point tyre clearance with largest rear tyre offered	76	—
Lower hitch point tractor clearance	204	—
Side-sway at hitch point each side of centre position with lower links horizontal ²⁾	50	—
<p>1) Permissible side-sway of the upper link is not specifically dimensioned; it shall however be compatible with that provided at the lower links plus necessary additional allowance for lateral levelling adjustment.</p> <p>2) Means should be provided to lock the lower links rigid laterally for operations where side-sway cannot be tolerated and when the hitch is raised ready for transport. No maximum dimensions for side-sway are specified; this shall be limited in each individual application so that hitch or implement components will not come in contact with the tractor tyres.</p>		

Table 3 — Lift range, power range and adjustments

Dimensions in millimetres

Measurement	Dimension	
	min.	max.
Lift range:		
Max. height for lowest position	—	180
Min. height for highest position	500	—
Power range	250	—
Levelling adjustment:		
Higher	50	—
Lower	50	—
Mast adjustment:		
Min. height for highest position	380	—
Max. height for lowest position	—	180

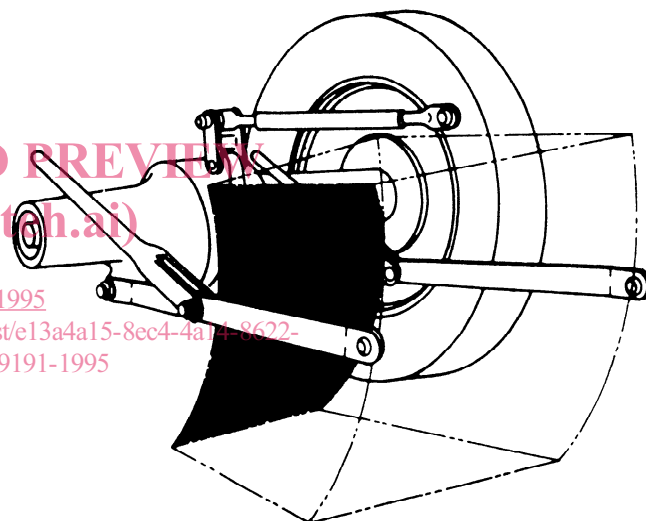
**Figure 4 — Lower hitch point tractor clearance**