

INTERNATIONAL STANDARD

**ISO
9195**

First edition
1992-06-15

Liquid flow measurement in open channels — Sampling and analysis of gravel-bed material

*Mesure de débit des liquides dans les canaux découverts —
Échantillonnage et analyse des matériaux du lit graveleux*
(standards.iteh.ai)

ISO 9195:1992

<https://standards.iteh.ai/catalog/standards/sist/e7f4549f-cb24-4ed4-a88c-626ff89aa0be/iso-9195-1992>



Reference number
ISO 9195:1992(E)

Contents

	Page
1 Scope	1
2 Normative references	1
3 Definitions	1
4 Sampling equipment and procedures	1
5 Assignment of grain sizes	2
6 Frequency	2
7 Grain size/frequency distributions	3
8 Selection of sampling procedure	4
9 Determination of sample size	6
10 Errors	8

iTeh STANDARD PREVIEW (standards.iteh.ai)

[ISO 9195:1992](https://standards.iteh.ai/catalog/standards/sist/e7f4549f-cb24-4ed4-a88c-626ff89aa0be/iso-9195-1992)

<https://standards.iteh.ai/catalog/standards/sist/e7f4549f-cb24-4ed4-a88c-626ff89aa0be/iso-9195-1992>

© ISO 1992

All rights reserved. No part of this publication may be reproduced or utilized in any form or by any means, electronic or mechanical, including photocopying and microfilm, without permission in writing from the publisher.

International Organization for Standardization
Case Postale 56 • CH-1211 Genève 20 • Switzerland

Printed in Switzerland

Foreword

ISO (the International Organization for Standardization) is a worldwide federation of national standards bodies (ISO member bodies). The work of preparing International Standards is normally carried out through ISO technical committees. Each member body interested in a subject for which a technical committee has been established has the right to be represented on that committee. International organizations, governmental and non-governmental, in liaison with ISO, also take part in the work. ISO collaborates closely with the International Electrotechnical Commission (IEC) on all matters of electrotechnical standardization.

Draft International Standards adopted by the technical committees are circulated to the member bodies for voting. Publication as an International Standard requires approval by at least 75 % of the member bodies casting a vote.

International Standard ISO 9195 was prepared by Technical Committee ISO/TC 113, *Measurement of liquid flow in open channels*, Subcommittee SC 6, *Sediment transport*.

[ISO 9195:1992](#)

<https://standards.iteh.ai/catalog/standards/sist/e7f4549f-cb24-4ed4-a88c-626ff89aa0be/iso-9195-1992>

Introduction

Bed material sampling techniques are used to obtain samples of sediment from the bed of a water course.

Information with respect to sediment sizes is required for estimating resistance to flow in open channels and, together with hydraulic data, for calculating bed material load and in making morphological forecasts.

iTeh STANDARD PREVIEW (standards.iteh.ai)

ISO 9195:1992

<https://standards.iteh.ai/catalog/standards/sist/e7f4549f-cb24-4ed4-a88c-626ff89aa0be/iso-9195-1992>

Liquid flow measurement in open channels — Sampling and analysis of gravel-bed material

1 Scope

1.1 This International Standard specifies methods for sampling surface and subsurface gravel-bed material and the analytical procedures to determine the size distribution of gravel-bed material in open channels.

1.2 This International Standard applies to material having diameters of 2 mm and over.

1.3 In practice, gravel-bed material may consist of two components: a coarser layer on the surface and finer subsurface material. Surface material is particularly relevant to investigations of the initiation of bed material movement and flow resistance, while subsurface material is mainly relevant to investigations of bed material transport. This International Standard does not attempt to correlate these two distinct populations.

1.4 There are two sampling techniques applicable to graded gravel-bed material. One method is to collect a definable *in situ* volume of material which is subsequently dealt with as a bulk sample. The second method is to sample material from the surface using one of several procedures. These two methods are discussed separately in this International Standard, and conversion factors are presented which are derived from idealized homogeneous material.

2 Normative references

The following standards contain provisions which, through reference in this text, constitute provisions of this International Standard. At the time of publication, the editions indicated were valid. All standards are subject to revision, and parties to agreements based on this International Standard are encouraged to investigate the possibility of applying the most recent editions of the standards in-

dicated below. Members of IEC and ISO maintain registers of currently valid International Standards.

ISO 772:1988, *Liquid flow measurement in open channels — Vocabulary and symbols*.

ISO 4364:1977, *Liquid flow measurement in open channels — Bed material sampling*.

3 Definitions

For the purposes of this International Standard, the definitions given in ISO 772 apply.

4 Sampling equipment and procedures

4.1 Surface samples

4.1.1 Grid sampling

A grid is established over the surface of the gravel deposit and the pebbles immediately below the grid intersection points constitute the sample. Variants on this method include the use of a set of regularly spaced points, for example footsteps, as grid points and collecting the stone immediately underfoot after one or more steps, by reaching down with eyes closed and collecting the stone first touched by an outstretched finger. For small square grid samples, less than 1 m², a vertical photograph can be taken of the grid-covered area or a scaled photograph can be taken and a grid applied to the photograph.

4.1.2 Areal sampling

All the surface pebbles within a selected area constitute the sample. If the gravel is exposed above water, it can be marked with spray paint to facilitate collection of the surface material.

4.1.3 Transect sampling

All the stones exposed under a straight line (wire or string) across the sampling area are collected.

4.2 Bulk samples

The samplers described in 4.2.1 to 4.2.4 are illustrative of the type that has been successfully used for bulk sampling. Actual dimensions of the pipe and gravel-cutter samplers may be modified to suit the size of material being sampled.

4.2.1 Pipe sampler

The sampler consists of a 0,4 m long \times 0,15 m diameter open pipe fixed into the bottom of a 0,5 m high \times 0,36 m diameter open-topped barrel (see figure 1). The pipe, which protrudes 0,26 m below the base of the barrel, is worked into the gravel until the bottom of the barrel is flush with the surface of the bed. The material in the pipe can be removed by hand or by scoop into the base of the barrel. This prevents the fines in the sample from being washed away. On completion of sampling, the pipe sampler is removed by hand from the bed of the river. The sampler, which can be used in up to 0,4 m of water, enables the surface and subsurface material to be sampled separately.

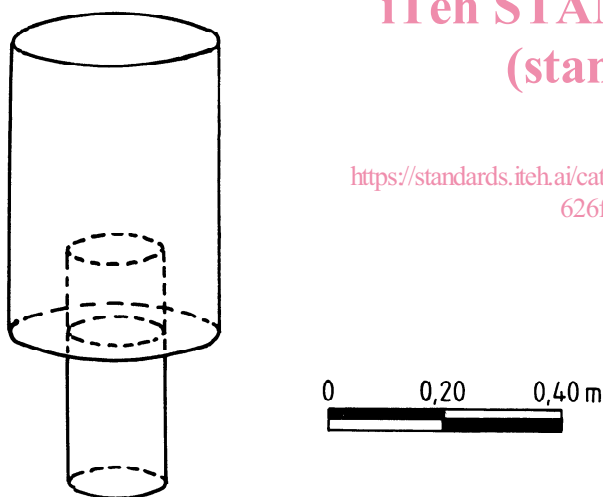

Figure 1 — Pipe sampler

4.2.2 Freeze-core sampler

A 20 mm internal diameter pipe with a fitted point is driven into the gravel bed. A tube connected to a carbon dioxide gas tank which has exhaust orifices is inserted into the pipe and carbon dioxide is injected for a few minutes. As it escapes, the expanding gas chills the pipe which causes the pore water near the pipe to freeze. The pipe is removed from the bed using a hoist attached to a portable tripod. This produces a relatively undisturbed sample of bed material about 100 mm to 150 mm in diameter. However, at high stream velocities the size of the

core is reduced due to heat transfer from the flowing water.

4.2.3 Gravel-cutter sampler

The sampler is made from an open drum 0,4 m long and 0,5 m diameter. A series of teeth are cut around the bottom perimeter and handles are added near the top. A rectangular metal sample box, 0,69 m long, 0,31 m deep and 0,41 m wide, with one end open and with handles on the narrow sides is placed on the downstream side of the sampler. The open end is curved along one of the 0,41 m sides to match the shape of the sampler and has an attached curved lip to hook on to it when in position. The opposite side of the box has a 0,16 m \times 0,25 m opening with a 200 mesh screen across it (see figure 2).

One or two people work the sampler several centimetres into the bed. Samples of surface and sub-surface material can then be collected by hand or with scoops. Divers are needed if the sampling depth exceeds 0,5 m. If the top of the sampler is submerged, the sample box is used for temporary storage to minimize the risk of losing fines. The screened opening permits a slight current to enter and move through the box, so that fines suspended during sampling are carried into and retained by the sample box together with the scooped material. On completion of sampling, the box is lifted out of the water by hand or with a boat winch.

4.2.4 Gravel excavators

In boulder-bed channels, large samples are required and this necessitates the use of earth excavators or similar equipment to obtain the requisite volume of sample.

5 Assignment of grain sizes

Once the sample has been collected or photographed, it is necessary to assign a linear measure of the size of each stone. Generally, the intermediate or b-axis of the stone is used for this purpose and it can be measured with square mesh sieves, calipers or, in the case of surface samples, from photographs, assuming that the b-axis corresponds to the smaller visible axis.

6 Frequency

After the sampled gravel has been measured, it is divided into size classes, each class containing a percentage of the original sample. Approximately twenty classes are required although it is not necessary for them to have a fixed class interval. The percentages in each class can also be regarded as frequencies of occurrence. There are essentially two ways of establishing grain size/frequencies.

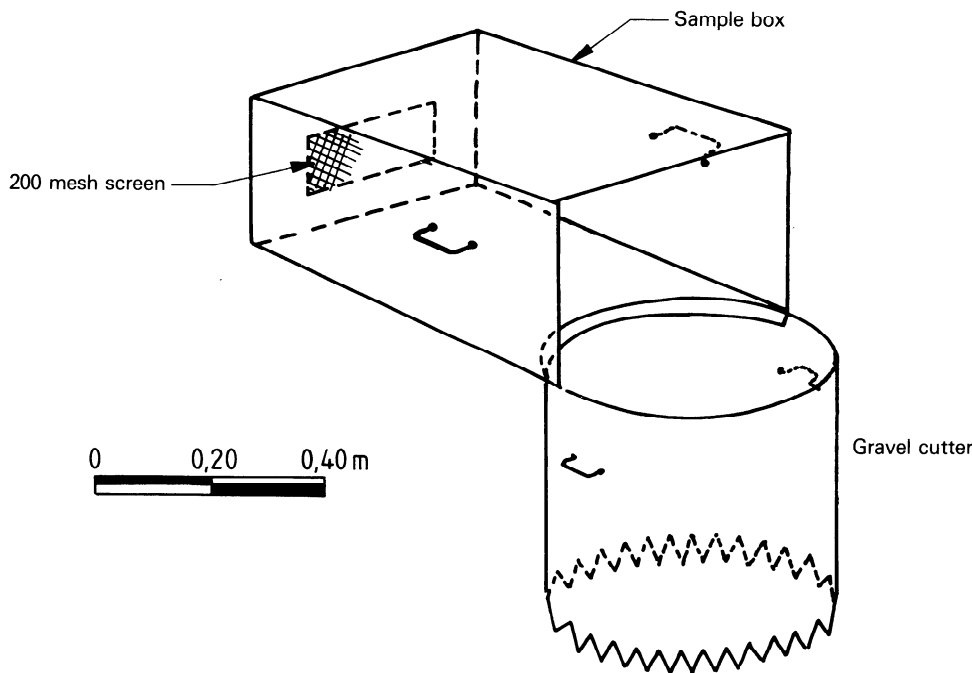

Figure 2 — Gravel-cutter sampler
 iTeh STANDARD PREVIEW
 (standards.iteh.ai)

ISO 9195:1992

6.1 Frequency by mass can be obtained by standard statistical procedures after transforming all the measurements to \log_{10} values.

The frequency of each size interval is expressed as the percentage by mass of the original sample falling into the interval. Bulk samples are normally analysed in this manner. Surface samples can be expressed in this way, although calculations from photographs are based on estimates of particle volumes from size measurements, assuming a constant density.

6.2 Frequency by number

The frequency of each size interval is expressed as the percentage by number of the total number of particles in the original sample that fall in the interval. Surface samples, especially of coarse gravel and cobbles, are often analysed in this manner.

7 Grain size/frequency distributions

7.1 Surface samples

Surface gravel samples, irrespective of the type of sampling procedure and frequency determination, are characteristically log-normally distributed. The mean and standard deviation of the logarithmic distribution define the frequency distribution and they

can be obtained by standard statistical procedures after transforming all the measurements to \log_{10} values. The simplest way of determining the characteristics of the logarithmic distribution is to construct a cumulative size distribution (percentage finer than specified size) and plot this on logarithmic (base 10)/normal probability paper. The median sample size is equal to the $\lg D_{50}$, where D_{50} is the median grain size (in millimetres).

The sample geometrical standard deviation (s) is estimated by

$$s = \frac{1}{2} \lg \left(\frac{D_{84}}{D_{16}} \right)$$

or by

$$s = \lg \frac{1}{2} \left(\frac{D_{84}}{D_{50}} + \frac{D_{50}}{D_{16}} \right)$$

where 84 %, 50 %, and 16 % of the bed material are finer than or equal to D_{84} (in millimetres), D_{50} (in millimetres), and D_{16} (in millimetres) respectively.

The cumulative curve can also be used to establish the percentage (n) of the bed material finer than or equal to any specified grain diameter (D_n millimetres). D_{90} , D_{84} and D_{65} are commonly used for flow resistance investigations.

7.2 Bulk samples

Bulk samples, irrespective of the type of frequency classification, are approximately log-normally distributed and often modal. Although there are no simple statistical procedures for defining such distributions, values of grain diameter (D_n millimetres), which are less than or equal to n per cent of the sample can be obtained from a cumulative grain size curve. Typical values used in sediment transport investigations are D_{35} , D_{50} and D_{65} .

8 Selection of sampling procedure

The following clauses are intended to give general guidance only. Specific investigations may require particular siting.

8.1 Selection of site

The first step in site selection is to delineate a homogeneous reach. This reach is defined by morphologic characteristics and is usually at least one meander wavelength, two pools and riffles, or 50 channel widths in length.

Within a homogeneous reach, specific sites should be located for sampling of the coarser material, as this is associated with the channel-forming processes and sediment transport. In order of priority (see figure 3) such sites are:

- a) near the upstream end of centrally located features such as mid-channel bars, diamond bars, and diagonal bars;
- b) near the upstream end of a point bar;
- c) near the upstream end of a channel side bar;
- d) at the head of a riffle (normally for smaller streams).

Consistency of sampling procedures and sampled sedimentary environments is essential.

8.2 Sampling

The choice of sampling procedure is dependent on the characteristics of the bed material, the flow depth, the requirements of the survey, and the time available.

8.2.1 Surface samples

8.2.1.1 Grid sampling can be carried out on exposed gravel-bars and, using pacing techniques, for collecting stones in water up to about 1 m deep. Use of photographic techniques enables the size of the

surface material larger than 20 mm to be estimated without disturbing its structure, allows rapid field survey, and can be used in clear water to a depth of 0,5 m.

8.2.1.2 Areal sampling procedures can be used underwater, to a maximum depth of about 0,5 m, and on exposed gravel bars.

8.2.1.3 Transect sampling is restricted to use on exposed gravel bars.

8.2.2 Bulk samples

8.2.2.1 Pipe samplers, described in 4.2.1, can be used only in water up to a depth of 0,4 m. The diameter of the pipe restricts the use of the sampler to a particular size range of material. A pipe diameter of 0,15 m is generally suitable for sampling gravel finer than 50 mm (see 9.2).

8.2.2.2 Freeze core samplers can be used in water at depths of up to 0,6 m and are best suited for gravel and finer material. The method is ideal for the investigation of sedimentary structures as the sample is relatively undisturbed.

8.2.2.3 Gravel-cutter samplers can be used in water at depths up to 1,0 m and at velocities as high as $1,5 \text{ m} \cdot \text{s}^{-1}$. The larger diameter of this type of sampler (up to 0,5 m) enables it to be used for coarser bed material. A maximum intermediate diameter of approximately 150 mm can be sampled with the 0,5 m diameter sampler (see 9.2).

8.2.2.4 Gravel excavators are generally required when the maximum size of the material to be sampled has an intermediate diameter in excess of 150 mm.

8.2.3 Conversion factors

The relation between the different methods of sampling has been established for the idealized case of densely packed cubes in random arrangement (table 1). This indicates that the grid sample by number frequency method will be equivalent to the bulk sample by mass frequency procedure, provided that the surface layer is a random slice through the population of material being sampled. Actual conversion factors will depend on the shape of the material and the degree to which a coarser layer has developed on the surface.

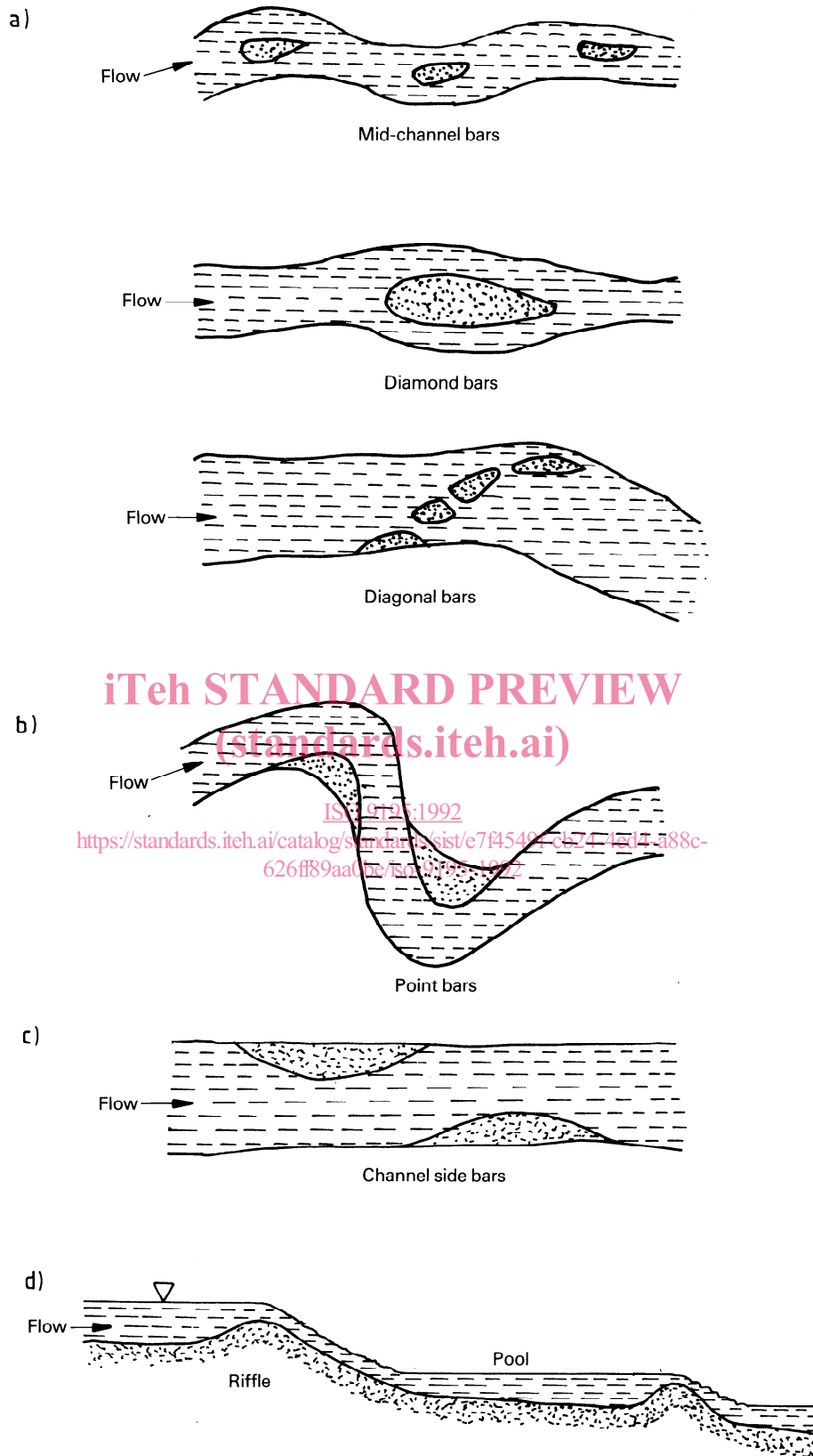

Figure 3 — Sampling site selection hierarchy