



Standard Specification for Evaluation of Structural Composite Lumber Products¹

This standard is issued under the fixed designation D 5456; the number immediately following the designation indicates the year of original adoption or, in the case of revision, the year of last revision. A number in parentheses indicates the year of last reapproval. A superscript epsilon (ϵ) indicates an editorial change since the last revision or reapproval.

INTRODUCTION

Structural composite lumber is intended for use as an engineering material for a variety of end-use applications. The composition of the lumber varies by wood species, adhesive composition, wood element size, shape, and arrangement. To provide the intended performance, composite lumber products require: (1) an evaluation of the mechanical and physical properties and their response to end-use environments, and (2) establishment of and conformance to standard performance specifications for quality.

Procedures contained in this specification are also to be used for establishing the design properties and for checking the effectiveness of property assignment and quality assurance procedures.

The quality assurance sections in this specification are intended to serve as a basis for designing quality-control programs specific to each product. The objective is to ensure that design values established in the qualification process are maintained.

This specification is arranged as follows:

	Section
Qualification	6
Determination of Allowable Design Stresses	7
Independent Inspection	8
Quality Assurance	10

1. Scope

1.1 This specification recognizes the complexity of structural glued products. Consequently, this specification includes both specific procedures and statements of intent that sampling and analysis must relate to the specific product.

1.2 This specification was developed in the light of currently manufactured products as defined in 3.2. Materials that do not conform to the definitions are beyond the scope of this specification. A brief discussion is found in Appendix X1.

1.3 Details of manufacturing procedures are beyond the scope of this specification.

NOTE 1—There is some potential for manufacturing variables to affect the properties of members that are loaded for sustained periods of time. Users of this specification are advised to consider the commentary on this topic, in Appendix X1.

1.4 This specification primarily considers end use in dry service conditions such as with most protected framing members, where the average equilibrium moisture content for solid-sawn lumber is less than 16 %. The conditioning envi-

ronment of 6.3 is considered representative of such uses.

1.5 The performance of structural composite lumber is affected by wood species, wood element size and shape, adhesive and production parameters. Therefore, products produced by each individual manufacturer shall be evaluated to determine their product properties, regardless of the similarity in characteristics to products produced by other manufacturers. Where a manufacturer produces product in more than one facility, each production facility shall be evaluated independently. For additional production facilities, any revisions to the full qualification program in accordance with this specification shall be approved by the independent qualifying agency.

1.6 This specification is intended to provide manufacturers, regulatory agencies, and end users with a means to evaluate a composite lumber product intended for use as a structural material.

1.7 This specification covers initial qualification sampling, mechanical and physical tests, analysis, and design value assignments. Requirements for a quality-control program and cumulative evaluations are included to ensure maintenance of allowable design values for the product.

1.8 This specification, or parts thereof, shall be applicable to structural composite lumber portions of manufactured structural components.

1.9 The values stated in inch-pound units are to be regarded

¹ This specification is under the jurisdiction of ASTM Committee D07 on Wood and is the direct responsibility of Subcommittee D07.02 on Lumber and Engineered Wood Products.

Current edition approved Sept. 10, 2001. Published November 2001. Originally published as D 5456 – 93. Last previous edition D 5456 – 01.

as the standard. The SI units given in parentheses are for information only.

1.10 *This standard does not purport to address all of the safety concerns, if any, associated with its use. It is the responsibility of the user of this standard to establish appropriate safety and health practices and determine the applicability of regulatory limitations prior to use.*

2. Referenced Documents

2.1 ASTM Standards:

- C 177 Test Method for Steady-State Heat Flux Measurements and Thermal Transmission Properties by Means of the Guarded-Hot-Plate Apparatus²
- C 355 Test Methods for Water Vapor Transmission of Thick Materials³
- C 384 Test Method for Impedance and Absorption of Acoustical Materials by the Impedance Tube Method²
- C 423 Test Method for Sound Absorption and Sound Absorption Coefficients by the Reverberation Room Method²
- D 7 Test Method for Sieve Analysis of Fine Aggregates⁴
- D 9 Terminology Relating to Wood⁵
- D 143 Test Methods for Small Clear Specimens of Timber⁵
- D 150 Test Methods for AC Loss Characteristics and Permittivity (Dielectric Constant) of Solid Electrical Insulating Materials⁶
- D 198 Test Methods of Static Tests of Lumber in Structural Sizes⁵
- D 245 Practice for Establishing Structural Grades and Related Allowable Properties for Visually Graded Lumber⁵
- D 669 Test Method for Dissipation Factor and Permittivity Parallel With Laminations of Laminated Sheet and Plate Materials⁶
- D 905 Test Method for Strength Properties of Adhesive Bonds in Shear By Compression Loading⁷
- D 1666 Methods for Conducting Machining Tests of Wood and Wood-Base Materials⁵
- D 1761 Test Methods for Mechanical Fasteners in Wood⁵
- D 2132 Test Method for Dust-and-Fog Tracking and Erosion Resistance of Electrical Insulating Materials⁶
- D 2394 Methods for Simulated Service Testing of Wood and Wood-Base Finish Flooring⁵
- D 2395 Test Methods for Specific Gravity of Wood and Wood-Base Materials⁵
- D 2559 Specification for Adhesives for Structural Laminated Wood Products for Use Under Exterior (Wet Use) Exposure Conditions⁷
- D 2718 Test Method for Structural Panels in Planar Shear (Rolling Shear)⁵
- D 2915 Practice for Evaluating Allowable Properties for Grades of Structural Lumber⁵
- D 3201 Test Method for Hygroscopic Properties of Fire-Retardant Wood and Wood-Base Products⁵

- D 3755 Test Method for Dielectric Breakdown Voltage and Dielectric Strength of Solid Electrical Insulating Materials Under Direct-Voltage Stress⁸
 - D 4442 Test Methods for Direct Moisture Content Measurement of Wood and Wood-Base Materials⁵
 - D 4761 Test Methods for Mechanical Properties of Lumber and Wood-Base Structural Material⁵
 - D 4933 Guide for Moisture Conditioning of Wood and Wood-Base Materials⁵
 - D 5055 Specification for Establishing and Monitoring Structural Capacities of Prefabricated Wood I-Joists⁵
 - D 5457 Specification for Computing the Reference Resistance of Wood-Based Materials and Structural Connections for Load and Resistance Factor Design⁵
 - D 5764 Test Method for Evaluating Dowel Bearing Strength of Wood and Wood-Based Products⁵
 - E 84 Test Method for Surface Burning Characteristics of Building Materials⁹
 - E 119 Test Methods for Fire Tests of Building Construction and Materials⁹
- ### 2.2 Canadian Standards:
- CAN3-O86-M84 Engineering Design in Wood (Working Stress Design)¹⁰
 - CSA Standards for Wood Adhesives, O112 Series¹⁰

3. Terminology

3.1 *Definitions*—Standard definitions of wood terms are given in Terminology D 9.

3.2 *Definitions of Terms Specific to This Standard:*

3.2.1 *laminated veneer lumber*—a composite of wood veneer sheet elements with wood fibers primarily oriented along the length of the member. Veneer thickness shall not exceed 0.25 in. (6.4 mm).

3.2.2 *parallel strand lumber*—a composite of wood strand elements with wood fibers primarily oriented along the length of the member. The least dimension of the strands shall not exceed 0.25 in. (6.4 mm) and the average length shall be a minimum of 150 times the least dimension.

3.2.3 *structural composite lumber*—in this specification, structural composite lumber (SCL) is either laminated veneer lumber (LVL) or parallel strand lumber (PSL). These materials are intended for structural use and they shall be bonded with an exterior adhesive.

3.2.3.1 *Discussion*—Structural composite lumber has three mutually perpendicular directions of orientation (see Fig. 1):

L Direction—Parallel to the longitudinal direction of the member.

X Direction—Parallel to a surface of the member and normal to the *L* direction.

Y Direction—Normal to both *L* and *X* direction.

In this specification, longitudinal shear means shear stress in the *L-X* and *L-Y* planes. Planar shear is stress in the *X-Y* plane.

4. Materials

4.1 *Wood Elements*—Wood elements used in the fabrication of SCL products shall conform to those specified in Section 3, Terminology.

² Annual Book of ASTM Standards, Vol 04.06.

³ Discontinued; see 1982 Annual Book of ASTM Standards, Part 18.

⁴ Discontinued; see 1937 Annual Book of ASTM Standards, Part 1.

⁵ Annual Book of ASTM Standards, Vol 04.10.

⁶ Annual Book of ASTM Standards, Vol 10.01.

⁷ Annual Book of ASTM Standards, Vol 15.06.

⁸ Annual Book of ASTM Standards, Vol 10.02.

⁹ Annual Book of ASTM Standards, Vol 04.07.

¹⁰ Available from Canadian Standards Association, 178 Rexdale Blvd., Toronto, Ontario, Canada M9W 1R3.

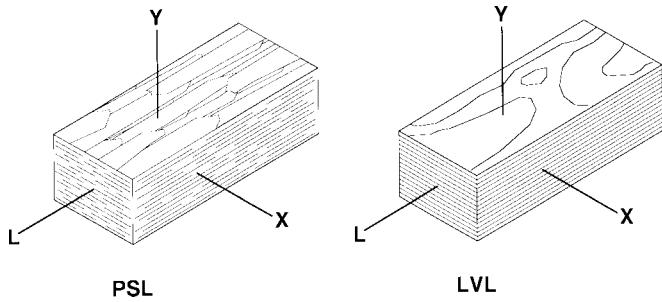

FIG. 1 Orientations for Structural Composite Lumber

4.2 Adhesives—Adhesives used in the fabrication of SCL products shall conform to the requirements in Specification D 2559 or, in Canada, to the appropriate section of CSA 0112 Series M standards for wood adhesives.

4.2.1 For high-temperature curing adhesives, the test samples shall be fabricated and tested in accordance with Specification D 2559 but with the following modifications:

4.2.1.1 The Shear by Compression Loading samples shall be fabricated by hot-pressing two 3/4-in. (19.1-mm) thick solid wood members in accordance with Test Method D 905 as allowed in Section 13.1.1 of Specification D 2559.

4.2.1.2 The Delamination During Accelerated Exposure samples shall be cut from a six-solid wood laminate member fabricated with four hot-set bondlines and one Specification D 2559-approved cold-set bondline in the center.

5. Mechanical Properties

5.1 The characteristic value for structural composite lumber is a statistic derived from test data as specified in 7.1. For bending and tension parallel to grain, the characteristic value is obtained at the unit volume as specified in 6.5.1 and 6.5.2.

5.2 The design stress related to structural composite lumber is derived from the characteristic value through application of the adjustments listed in Table 1 of this specification.

5.3 The allowable design stress published for engineering use shall be derived from the design stress modified by factors given in 7.3.

6. Qualification

6.1 Samples for qualification testing shall be representative of the population being evaluated. When an intentional modification to the process results in a reduction in mechanical

TABLE 1 Adjustment Factors

NOTE 1—Apparent modulus of elasticity is computed from a deformation, and compression strength perpendicular to grain is established at a deformation limit. Neither is subject to load duration adjustments. All other factors are the product of 1.62, that adjusts data to normal duration as defined in 7.3.1 of Practice D 245, and an additional factor for uncertainty.

Property	Adjustment Factor
Apparent modulus of elasticity	1.00
Bending strength	2.10
Tensile strength parallel to grain	2.10
Compressive strength parallel to grain	1.90
Longitudinal shear strength	3.15
Compressive strength perpendicular to grain	1.67

properties as indicated by the quality-control program, then new qualification is required.

6.1.1 Qualification tests shall be conducted or witnessed by a qualified agency in accordance with 8.1. All test results are to be certified by the qualified agency.

6.2 Sampling of the test material shall be done in accordance with applicable portions of Section 3, “Statistical Methodology,” of Practice D 2915.

6.2.1 Design stress, except for compression perpendicular to grain and apparent modulus of elasticity, shall be based on the fifth percentile tolerance limit.

6.2.2 The confidence level for calculating tolerance limits and confidence intervals shall be 75 %.

6.2.3 Minimum sample size for calculating tolerance limits on fifth percentiles shall be 53. When volume effect tests are made at multiple sizes for bending and tension, the minimum sample shall be 78 specimens at the unit volume specimen size.

6.2.3.1 The calculated fifth percentile parametric tolerance limits (PTL) shall have a standard error no greater than 5 % of the PTL, when evaluated in accordance with 3.4.3.2 of Practice D 2915. When necessary the sample shall be increased beyond the minimum of 53, to meet this requirement.

6.2.4 Minimum unit sample sizes for compression perpendicular to grain (see 6.5.4) shall provide estimation of mean values within 5 % in accordance with 3.4.2 of Practice D 2915. Minimum sample size shall not be less than 30.

6.3 Composite lumber used in qualification testing shall be brought to moisture equilibrium in a conditioned environment of 20 ± 6°C (68 ± 11°F) and 65 % (±5 %) relative humidity. Methods for determination of completion of conditioning are given in Guide D 4933.

6.4 Moisture content and specific gravity shall be measured and reported for each specimen tested in the qualification program. Measurement for moisture content shall be in accordance with Test Methods D 4442 and measurement of specific gravity shall be in accordance with Test Methods D 2395.

6.5 Mechanical Properties—The properties that shall be evaluated by qualification testing shall include, but are not limited to: bending strength and stiffness, tensile strength parallel to the grain, compressive strength parallel to the grain, compressive strength perpendicular to the grain, and longitudinal shear strength.

6.5.1 Bending—Modulus of rupture and apparent modulus of elasticity shall be determined for both flatwise and edgewise bending in accordance with principles of Test Methods D 198 or Test Methods D 4761. Specimen cross section shall not be less than the minimum anticipated structural size. Selection of specimen dimensions establishes the unit volume for the analysis of 7.4.1. Loading at third points and a span to depth ratio in the range from 17 to 21 shall be used for flatwise and edgewise bending.

NOTE 2—A span to depth ratio of 18 is a frequent international standard.

6.5.1.1 When either or both the size and moisture content of the qualification specimens will differ from specimens to be tested in quality control, the bending tests of 6.5.1 shall also be conducted on specimens of the size and the moisture content that will prevail at the time of routine quality-control testing.

The specimens representing the quality-control conditions shall be matched with those to be conditioned (see 6.3). The ratio of the means of both strength and stiffness shall be used to adjust quality-control test results to the qualification level, for use in the confirmation required in 10.6.1.

6.5.1.2 Moisture content is recognized as different when the discrepancy between the average of the two test sets is one percentage point of moisture content or more. Sample size shall be the same for both test sets and not less than 78.

6.5.1.3 If testing is required in accordance with 6.5.1.1, the coefficient of variation of the bending strength from those tests shall be the basis for comparison required in 10.6.3. Otherwise, the coefficient of variation of the bending strength from the tests in 6.5.1 shall be the basis.

6.5.2 *Tension Parallel to Grain*—Tension strength parallel to grain shall be tested in accordance with principles of Test Methods D 198 or Test Methods D 4761. Specimen cross section shall not be less than the minimum anticipated structural size. Specimen length shall provide for a minimum length of 36 in. (915 mm) between grips. Selection of specimen dimensions establishes the unit volume for the analysis of 7.4.1.

6.5.2.1 When either or both the size and moisture content of the qualification specimens will differ from specimens to be tested in quality control, the tension tests of 6.5.2 shall also be conducted on specimens of the size and the moisture content which will prevail at the time of routine quality-control testing. The specimens representing the quality-control conditions shall be matched with those to be conditioned (see 6.3). The ratio of the means of strength shall be used to adjust quality-control test results to the qualification level, for use in the confirmation required in 10.6.1. Moisture content is recognized as different when the discrepancy between the average of the two test sets is one percentage point of moisture content or more. Sample size shall be the same for both test sets and not less than 78.

6.5.2.2 If testing is required in accordance with 6.5.2.1, the coefficient of variation of the tensile strength from those tests shall be the basis for comparison required in 10.6.3. Otherwise, the coefficient of variation of the tensile strength from the tests in 6.5.2 shall be the basis.

6.5.3 *Compression Parallel to Grain*—Short-column compression strength parallel to grain shall be determined in accordance with principles of Test Methods D 198 or Test Methods D 4761. Minimum cross section shall be 1.5 by 1.5 in. (38 by 38 mm). Length of the specimen shall be such that L/r is less than 17 and greater than 15, where L is the effective unsupported length and r is the least radius of gyration.

6.5.4 *Compression Perpendicular to Grain*—Compressive strength perpendicular to grain shall be determined in accordance with principles of Test Methods D 143 except that references to placement of growth rings are not applicable and minimum cross-section dimension is 1.5 in. (38 mm). Stress at both 0.02- and 0.04-in. (0.5- and 1.0-mm) deformation shall be reported. Testing shall be done with stresses applied normal to the L - X plane in one test series and to the L - Y plane in another series.

6.5.5 *Longitudinal Shear*—Longitudinal shear strength

shall be determined in accordance with principles of Test Methods D 143 except that a minimum dimension of 1.5 in. (38 mm) at the shear area is acceptable provided that the total shear area is 4 in.² Testing shall be done to produce shear failure in the L - X plane in one test series and in the L - Y plane in another series.

6.5.5.1 If anticipated end use involves shear perpendicular to grain on a face of the material (planar shear), testing shall establish allowable shear stress in accordance with the principles of Test Method D 2718.

6.6 *Connections*—Determination of allowable design values for withdrawal capacities of nails, and dowel bearing capacities of bolts, lag screws, wood screws and nails is specified in Annex A2. Determination of allowable design values for other connectors is beyond the scope of this specification.

6.7 *Physical Properties*—Physical properties must be assessed when they affect end use. Information on physical properties and related standards is given in Appendix X1.

7. Determination of Allowable Design Stresses

7.1 Allowable design values developed in this section are consistent with engineering practice in building construction. Their applicability in other types of structures has not been evaluated and such applications require independent evaluation.

7.2 *Characteristic Value*—In the derivation of the characteristic value, the procedures of Sections 3 and 4 of Practice D 2915 shall be followed, except that provisions of this specification govern where differences occur.

7.2.1 The fifth percentile tolerance limit (TL) with 75 % confidence from test results of 6.5 shall be the characteristic value for strengths in flexure, tension parallel to grain, compression parallel to grain, and longitudinal shear.

7.2.1.1 Parametric or nonparametric analysis shall be performed to obtain a fifth percentile tolerance limit.

7.2.1.2 For parametric analysis either the normal or lognormal distribution shall be used to establish a fifth percentile tolerance limit with 75 % confidence. The distribution selection shall be based on standard statistical goodness of fit tests. As a minimum the fit selection shall include visual inspection of cumulative frequency plots of the fitted distributions with the data and the lesser of standard errors of the estimate from the two distributions fitted by the method of least squares.

NOTE 3—Experience has shown that data from SCL typically has coefficients of variation (COV) less than 20 % and is symmetrical to slightly right skewed and, therefore, are reasonably described by the normal and lognormal distributions. Goodness of fit references are given in Note 5 of Practice D 2915. The minimum procedures of 7.2.1.2 are detailed in X4.7 of Specification D 5055.

7.2.2 The average value for apparent modulus of elasticity from test results of 6.5.1 shall be the characteristic value for apparent modulus of elasticity.

7.2.3 The average value at 0.04-in. (1.0-mm) deformation for compression perpendicular to grain from test results of 6.5.4 shall be the characteristic value for compression perpendicular to grain.

7.3 *Design Stresses*—Design stresses shall be calculated from the characteristic value defined in 7.2 in accordance with

the following formula:

$$S = \frac{B}{C_a} \quad (1)$$

where:

- S = design stress,
- B = characteristic value, and
- C_a = adjustment factor from Table 1.

7.4 Allowable Design Stress—Design stresses shall be modified by factors that consider the end-use applications as follows:

$$F_a = C_e S \quad (2)$$

where:

- F_a = allowable design stress,
- C_e = product of end use (K) factors, and
- S = design stress.

Factors common to all members are detailed in this section.

7.4.1 Volume Factors:

7.4.1.1 Strength properties are affected by the relative volume at a given stress. For purposes of this section, the members tested in edge bending or axial tension in Section 6 shall be taken as a unit volume. Sections other than solid rectangles, or solid rectangular sections not loaded axially or normal to one of its surfaces, require special investigation.

7.4.1.2 Volume factors shall either be determined from the prescribed theoretical relationships or by testing on a range of sizes, as detailed in Annex A1.

7.4.1.3 Bending—Bending design stress shall be adjusted for volume effect by multiplication with the factor as follows:

$$K_d = \left(\frac{d_1}{d}\right)^{2m} = \left(\frac{d_1}{d}\right)^{1/n} \quad (3)$$

where:

- K_d = factor applied to design stress of the member of unit volume,
- d_1 = depth of unit volume members,
- d = depth of an application member,
- m = a parameter determined in accordance with Annex A1, and
- n = $m/2$

NOTE 4—A derivation of Eq 3 is given in Ref (1)¹¹ along with example data. In this case, volume considered is only two-dimensional since, at least within the limits given in Annex A1, increasing width of SCL bending members does not result in strength reduction. In some cases tests show a strength increase with increasing width, possibly because of greater stability along the compression edge. Therefore the two-dimensional form of the equation is of the form $K_d = (d_1/d)^{1/m}(L_1/L)^{1/m}$ where L_1 and L is the length of the unit volume and application member, respectively. When a constant span/depth ratio is assumed, Eq 3 becomes $K_d = (d_1/d)^{2/m}$, which can be further simplified to $K_d = (d_1/d)^{1/n}$, where $n = m/2$.

7.4.1.4 Axial Tension—Tensile design stress shall be adjusted for volume by multiplication with factor as follows:

$$K_L = \left(\frac{L_1}{L}\right)^{1/m} \quad (4)$$

where:

- K_L = adjustment factor,
- L_1 = base length between grips tested in 6.5.2,
- L = end-use length, and
- m = parameter determined in accordance with Annex A1.

NOTE 5—Tension tests of SCL do not show strength reductions for increasing cross section so that volume is represented by length alone. Annex A1 states criteria for accepting this approach without limitations. Ref (1) gives example data.

7.4.1.5 When volume effect factors are based on single-size testing in accordance with A1.2.3, increased design stresses for members smaller than that tested are not permitted.

7.4.1.6 Other related conditions which influence the bending strength of a member include the loading diagram and support condition. Adjustments for common load cases are given in Annex A1 and other information is found in Ref (2).

7.4.2 Allowable design stresses developed in this specification correspond to the condition of normal loading as defined in 7.2 of Practice D 245 and 4.4.1 of CAN3-086-M84. These stresses shall be adjusted for other loading durations using the same factors applied to sawn lumber and other wood and wood-based structural members, as defined in Ref (3) or CAN3-086-M84.

7.4.3 Allowable design stresses developed in this specification are for use in dry conditions as defined in 1.4. If use at other moisture conditions is intended, a documented test-based investigation leading to appropriate properties adjustment must be carried out.

7.4.4 Other End-Use Adjustments—In some cases, end use requires other adjustments. A brief discussion of such use conditions is given in Appendix X1.

7.5 To convert allowable design stresses to load and resistance factor design (LRFD) format use the procedures of Specification D 5457.

8. Independent Inspection

8.1 A qualified agency shall be employed by the manufacturer for the purpose of monitoring the quality assurance and production process on a random unannounced basis. The qualified independent agency shall establish or approve and monitor procedures for quality assurance.

8.2 Quality Agency—A qualified agency is defined to be one that:

8.2.1 Has access to the facilities and trained technical personnel to verify that the grading, measuring, species, construction, bonding, workmanship, and other characteristics of the products as determined by inspection, sampling, and testing comply with all applicable requirements specified herein;

8.2.2 Has procedures to be followed by its personnel in performance of the inspection and testing;

8.2.3 Has no financial interest in, or is not financially dependent upon, any single company manufacturing the product being inspected or tested, and

8.2.4 Is not owned, operated, or controlled by any such company.

¹¹ The boldface numbers in parentheses refer to a list of references at the end of the text.

9. Manufacturing Standard

9.1 A manufacturing standard, subject to the approval of the qualified agency, shall be written and maintained by the manufacturer for each product and each production facility. This specification shall include provision for quality assurance.

10. Quality Assurance

10.1 *Quality Assurance in Manufacturing Standard*—This portion of the manufacturing standard shall include subject matter necessary to the quality-assurance program including the following:

10.1.1 Material specifications, including incoming material inspection and acceptance requirements, and

10.1.2 Quality assurance, inspection, testing, and acceptance procedures.

10.1.2.1 Sampling and inspection frequencies shall be devised to encompass all variables that affect the quality of the finished product. Increased frequencies shall be used in connection with new or revised facilities. A random sampling scheme shall generally be used for specimen selection.

NOTE 6—Increased sampling and test frequency is a useful procedure when investigating apparent data trends or adjustments in the process. It is desirable at times to deviate from a random sampling scheme while investigating effects of specific variables.

10.1.3 Procedures to be followed upon failure to meet specifications or upon out-of-control conditions shall be specified. Included shall be reexamination criteria for suspect material and material rejection criteria.

10.1.4 Finished product marking, handling, protection, and shipping requirements as they relate to the performance quality of the product shall be defined.

10.2 *Inspection Personnel*—All manufacturing personnel responsible for quality control shall demonstrate to the qualified agency that they have knowledge of the inspection and test procedures used to control the process of the operation and calibration of the recording and test equipment used and of the maintenance and interpretation of quality-control records.

10.2.1 Use of quality-control records beyond quality control, for monitoring and adjusting allowable design values, requires special recognition. The independent inspection agency and manufacturing quality-control personnel must maintain continuing awareness of this additional responsibility.

10.3 *Record Keeping*—All pertinent records shall be maintained on a current basis and be available for review by the qualified agency personnel. As a minimum, such records shall include:

10.3.1 All inspection reports and records of test equipment calibration, including identification of personnel carrying out the tests;

10.3.2 All test data, including retests and data associated with rejected production, and

10.3.3 Details of any corrective actions taken and the disposition of any rejected production resulting from tests or inspections.

10.4 *Quality Assurance Testing:*

10.4.1 *Testing Equipment*—Testing equipment is to be properly maintained, calibrated, and evaluated for accuracy and adequacy at a frequency satisfactory to the qualified agency.

10.4.2 *Required Tests*—The following shall be considered to be the scope of a minimum testing program:

10.4.2.1 The bending test described in 6.5.1 shall be used for quality assurance of bending strength and stiffness.

10.4.2.2 The tension test described in 6.5.2 shall be used for quality assurance of tensile strength parallel to grain.

10.4.2.3 Moisture content data shall be determined by the same process as in 6.4, at a frequency that provides a representative sample of production.

10.4.2.4 When required, quality assurance data shall be adjusted by the factors of 6.5.1.1 and 6.5.2.1 prior to further analysis.

10.4.2.5 Test frequency for all tests shall be chosen to yield quality-assurance performance that is consistent with design stresses assigned to the product and its intended use.

10.5 *Process Control:*

10.5.1 Data from the tests of 10.4 shall be evaluated prior to shipping material represented by the sample. Analytic procedures shall determine if material properties are in statistical control. The control level selected shall be consistent with current design values and intended use of the material.

NOTE 7—References (4), (5), and (6) provide useful background material on quality control.

10.5.2 When the analysis of 10.5.1 indicates that the material properties are below the control level, the associated portion of production shall be subject to reexamination in accordance with acceptance procedures of 10.1.3.

10.6 *Cumulative Evaluation:*

10.6.1 *Design Stresses*—Periodically, characteristic values and associated allowable stress values shall be formally checked using data accumulated in 10.4. At least one such check shall be made in the first six months of operation involving new production or from any new product line. Thereafter analysis shall be conducted at intervals not to exceed one year.

10.6.2 *Analysis*—The periodic analysis shall be conducted in accordance with 7.1, 7.2, and 7.3. All data from the period associated with statistical process control shall be included in the analysis.

10.6.2.1 Design values must be affirmed by the analysis of 10.6.2 or be reduced accordingly.

10.6.2.2 When design values have been reduced in accordance with 10.6.2.1 or at the option of the producer because of excessive reject rates, a new statistical process control level in keeping with the new design value shall be established. The evaluation then includes all data from the period in statistical control based upon the new control level.

10.6.3 *Volume Effect*—If the coefficient of variation of bending strength, as computed directly from data analysis in 10.6.2, has increased by one and one-half percentage points or more over corresponding values determined in 6.5.1 or 6.5.2, the parameter (m) in Eq 3 and Eq 4 shall be recomputed using Eq A1.1.

11. Keywords

11.1 allowable design stresses; mechanical properties; quality assurance; structural composite lumber